

RS-232, RS-422, RS485 Multiprotocol Transceivers with Internal Termination and Wide Output Swing

UM3035B QFN40 6.0×6.0

1 Description

The UM3035B is highly integrated, robust and advanced multiprotocol transceiver supporting RS-232, RS-422 and RS-485 serial standards. The device offers three transmitters and five receivers in RS-232 mode to support 3T5R DB9 RS-232 connector. The device also integrates one transmitter and one receiver to support half and full duplex RS-485 communication. MODE selection pins enable shared bus and logic pins for the protocols to share a common single connector. Integrated termination resistance for RS-485 bus pins and for RS-232 receiver inputs need no external components to realize a fully-functional and switchable communication port.

The UM3035B operates up to 20Mbps in RS-485/RS-422 modes, and up to 1Mbps in RS-232 mode. What's more, based on the SLR pin setting, the UM3035B can be limited to 0.25Mbps low-speed RS-485 mode and 0.25Mbps low-speed RS-232 mode.

The device features integrated robust IEC ESD protection. What's more, diagnostic loopback mode for RS-232 is provided to check for logic to bus and bus to logic path functional integrity and check for cable and connector shorts. The RS-485 receiver fail-safe feature drives logic high on received logic output when the bus inputs are open or shorted together or when the bus is idle.

The UM3035B needs 3.0V to 5.5V supply that fully powers four external charge pump capacitors for RS-232 and the drivers/receivers for both RS-232 and RS-485. The device also features nSHDN pin to achieve extremely low current consumption when the system disables the device.

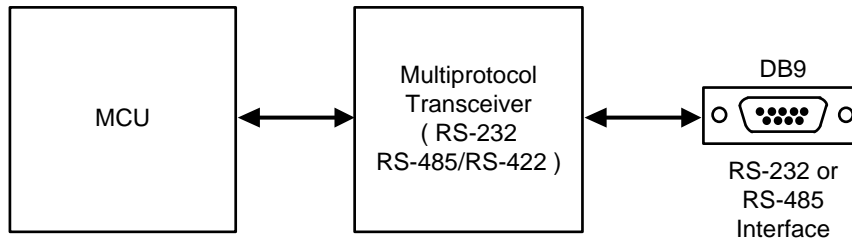
2 Features

- Meets or exceeds the requirements of the TIA/EIA-485A and TIA/EIA-232F standards
- 3 transmitters, 5 receivers for RS-232 port
- 1 transmitter, 1 receiver for RS-485 port
- Integrated switchable 120Ω termination resistor for half and full duplex RS-485 mode
- Integrated charge-pump for RS-232
- Large output swing (typical ±8.5V) for RS-232 mode with V_{CC} = 5V supply
- Diagnostic loopback for RS-232 mode
- Open, short, and idle bus failsafe for RS-485 receiver
- 3V to 5.5V supply voltage
- RS-485 differential output exceeds 2.1V for PROFIBUS compatibility with 5V supply
- Selectable Data Rates with SLR Pin:
 - RS-232 mode: 250kbps and 1Mbps
 - RS-485 half-duplex and full-duplex mode: 250kbps and 20Mbps
- Glitch-free power-up/down for hot plug-in capability
- Bus short-circuit protection, thermal Shutdown
- Extended ambient temperature range: -40°C to 125°C
- Space-saving QFN40 6.0×6.0 package

3 Applications

- Industrial
- HVAC Systems
- Point-of-sale terminals
- Factory automation and control
- Building automation
- Grid infrastructure

4 Simplified Schematic



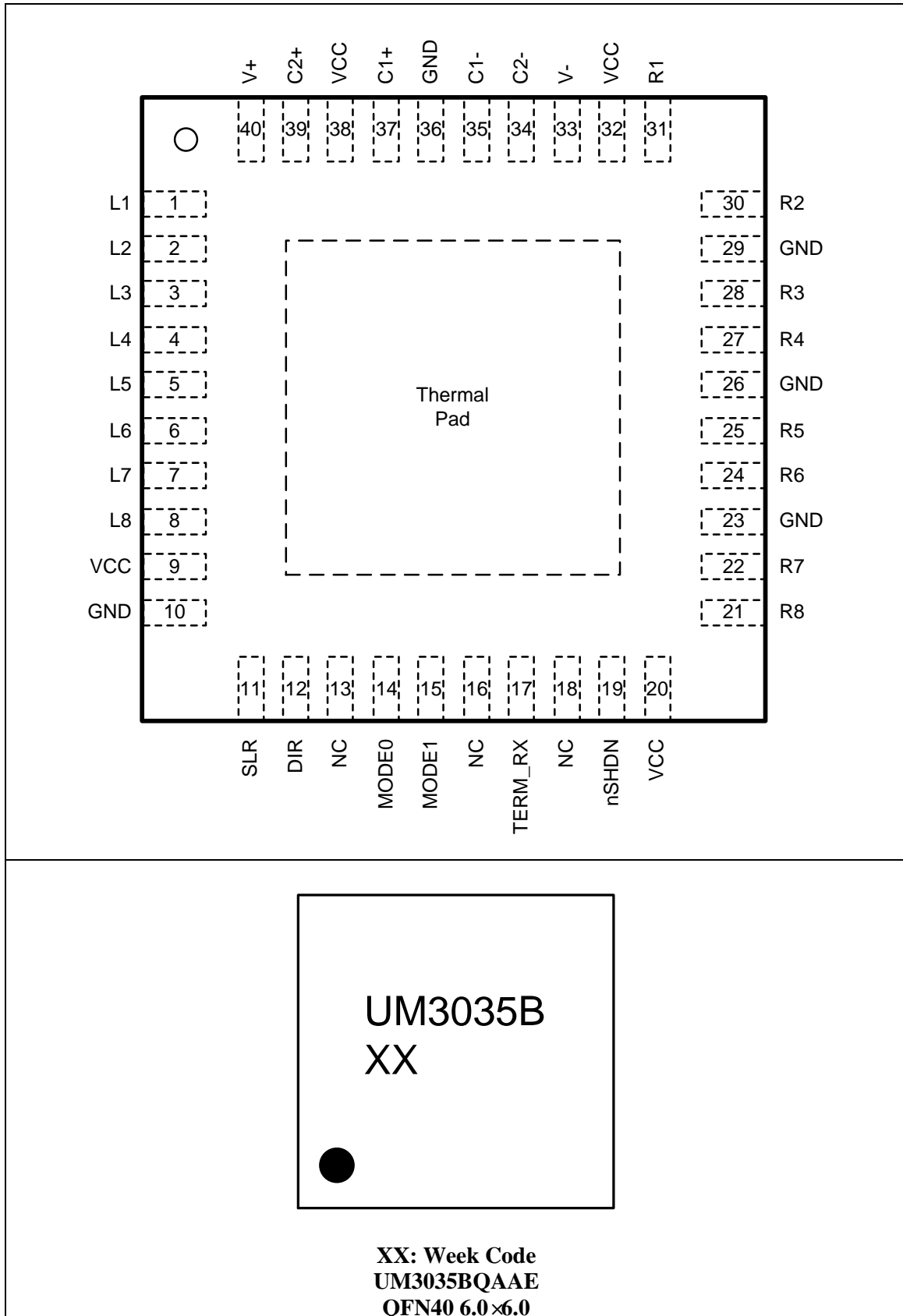
5 Selection Guide

Part Number	RS-232 Transceivers Number	RS-485 Transceivers Number	RS-232 Transceivers Data Rate (Mbps)	RS-485 Transceivers Data Rate (Mbps)
UM3035BQAAE	3T / 5R	1T / 1R	0.25 / 1	0.25 / 20

6 Ordering Information

Part Number	Mark Code	Package Type	Shipping Qty
UM3035BQAAE	UM3035B	QFN40 6.0×6.0	3000pcs/13Inch Tape & Reel

7 Pin Configuration and Function



7 Pin Configuration and Function (continued)

Table 7-1. Pin Functions of UM3035B

Pin No.	Pin Name	Function
1	L1	Logic output (RS-232)
2	L2	Logic output (RS-232/RS-485)
3	L3	Logic input (RS-232/RS-485). Integrated weak pull-up resistor.
4	L4	Logic input (RS-232). Integrated weak pull-up resistor.
5	L5	Logic output (RS-232)
6	L6	Logic input (RS-232), Integrated weak pull-up resistor.
7	L7	Logic output (RS-232)
8	L8	Logic output (RS-232)
9	VCC	3V to 5.5V supply voltage. (Note 1)
10	GND	Ground. (Note 2)
11	SLR	Slew rate control, internal pull-down resistor. SLR=H enables slow speed.
12	DIR	RS-485 TX/RX enable/disable. Internal pull-down resistor.
13	NC	Not connected internally. Can be connected to supply, ground or left open on PCB.
14	MODE0	MODE control pin 0, Integrated weak pull-down resistor.
15	MODE1	MODE control pin 1, Integrated weak pull-down resistor.
16	NC	Not connected internally. Can be connected to supply, ground or left open on PCB.
17	TERM_RX	RS485/RS-422 mode receiver 120 Ω Termination enable/disable. Internal Pull down resistor.
18	NC	Not connected internally. Can be connected to supply, ground or left open on PCB.
19	nSHDN	Device enable/disable. Internal pull-down resistor.
20	VCC	3V to 5.5V supply voltage. (Note 1)

7 Pin Configuration and Function (continued)

Table 7-1. Pin Functions of UM3035B

Pin No.	Pin Name	Function
21	R8	RS-232 receiver input.
22	R7	RS-232 receiver input.
23	GND	Ground. (Note 2)
24	R6	RS-232 driver output.
25	R5	RS-232 receiver input.
26	GND	Ground. (Note 2)
27	R4	RS-232 driver output or RS-485 inverting receiver input (B).
28	R3	RS-232 driver output or RS-485 non-inverting receiver input (A).
29	GND	Ground. (Note 2)
30	R2	RS-232 receiver input or RS-485 bus pin (Y or A).
31	R1	RS-232 receiver input or RS-485 bus pin (Z or B).
32	VCC	3V to 5.5V supply voltage. (Note 1)
33	V-	Negative charge pump rail.
34	C2-	Negative terminal of charge pump capacitor.
35	C1-	Negative terminal of charge pump capacitor.
36	GND	Ground. (Note 2)
37	C1+	Positive terminal of charge pump capacitor.
38	VCC	3V to 5.5V supply voltage. (Note 1)
39	C2+	Positive terminal of charge pump capacitor.
40	V+	Positive charge pump rail.

Note 1: All VCC pins must be powered by a common supply on PCB.

Note 2: All GND pins must be grounded on PCB.

8 Specifications

8.1 Absolute Maximum Ratings (Note 1)

Symbol	Parameter	Conditions	Min	Max	Unit
V _{CC}	Bus supply voltage	V _{CC} to GND	-0.5	6.0	V
V ₊	Charge pump positive-output supply voltage	V ₊ to GND	-0.3	14	V
V ₋	Charge pump negative-output supply voltage	V ₋ to GND	-14	0.3	V
V _{BUS}	Bus voltage at any bus pin	R1, R2, R3, R4, R5, R6, R7, R8 with respect to GND	-16	16	V
V _{ID}	Differential bus voltage	(R1-R2) or (R2-R1), (R3-R4) or (R4-R3) with termination disabled	-22	22	V
	Differential bus voltage at RS485 mode	(R1-R2) or (R2-R1), (R3-R4) or (R4-R3) with termination enabled	-6	6	V
V _I	Input voltage at any logic pin	L3, L4, L6, SLR, nSHDN, TERM_RX, MODE0, MODE1, DIR pins	-0.3	V _{CC} +0.2	V
V _{ESD}	Human-body model (HBM), per ANSI/ESDA/JEDEC JS-001	Bus terminals (R1, R2, R3, R4, R5, R6, R7, R8) and GND	-8	8	kV
I _O	Receiver output current	L1, L2, L5, L7, L8 pins	-8	8	mA
T _{STG}	Storage temperature		-65	150	°C
T _J	Junction temperature		-40	170	°C
T _L	Lead Temperature for Soldering 10 Seconds			260	°C

Note 1: Stresses beyond those listed under Absolute Maximum Ratings may cause permanent damage to the device. These are stress ratings only, which do not imply functional operation of the device at these or any other conditions beyond those indicated under Recommended Operating Conditions. Exposure to absolute-maximum-rated conditions for extended periods may affect device reliability.

8.2 Recommended Operating Conditions

Symbol	Parameter	Conditions	Min	Typ	Max	Unit
V _{CC}	Bus supply voltage		3		5.5	V
V _{I(RS-485)}	Input voltage at any bus terminal in RS-485 mode	R1, R2, R3, R4 pins	-7		12	V
V _{ID}	Differential input voltage in RS-485 receive mode [(R1-R2) or (R2-R1), (R3-R4) or (R4-R3)] with on-chip termination resistor disabled		-12		12	V
	Differential input voltage in RS-485 receive mode [(R1-R2) or (R2-R1), (R3-R4) or (R4-R3)] with on-chip termination resistor enabled		-5.5		5.5	V
V _{I(RS-232)}	Receiver input voltage in RS-232 mode	R1, R2, R5, R7, R8 pins	-15		15	V
V _{IH}	High-level input voltage	L3, L4, L6, SLR, nSHDN, TERM_RX, MODE0, MODE1, DIR pins	0.7V _{CC}		V _{CC}	V
V _{IL}	Low-level input voltage		0		0.3V _{CC}	V
I _O	Output current, driver in RS-485 mode		-60		60	mA
I _{OR}	Output current, receiver	V _{CC} = 3.3V or 5V	-4		4	mA
R _L	Differential load resistance in RS-485 mode		54	60		Ω
1/ t _{UI}	Signaling rate in RS-485 mode	SLR = V _{CC}			250	kbps
		SLR = GND or floating			20	Mbps
	Signaling rate in RS-232 mode	SLR = V _{CC}			250	kbps
		SLR = GND or floating			1	Mbps
1/ t _{UI(LOOPBACK)}	Signaling rate in RS-232 loopback mode				1	Mbps
T _A	Operating ambient temperature	Note 1	-40		125	°C

Note 1: Operation is specified for internal (junction) temperatures up to 150°C. Self-heating due to internal power dissipation should be considered for each application. Maximum junction temperature is internally limited by the thermal shutdown (T_{SD}) circuit which disables the driver and receiver when the junction temperature reaches 170°C.

8.3 Thermal Information

Symbol	Parameter		Value	Unit
R _{θJA}	Junction to ambient thermal resistance	QFN40 6.0×6.0	29.5	°C/W

8.4 Power Dissipation

Symbol	Parameter	Conditions	Min	Typ	Max	Unit
P _{D(RS-485)}	Full Duplex mode with DIR = V _{CC} , MODE1, MODE0 = 11, R2/R1 are externally connected to R3/R4 in loopback fashion; V _{CC} = 5.5 V, T _A = 125 °C, L3 = square wave 50% duty	Unterminated, TERM_RX = L, SLR = H (250kbps)		160	200	mW
		Unterminated, TERM_RX = L, SLR = L (20Mbps)		180	450	
		TERM_RX = V _{CC} , SLR = H (250kbps)		300	500	mW
		TERM_RX = V _{CC} , SLR = L (20Mbps)		260	575	
P _{D(RS-232)}	RS-232 mode with MODE1, MODE0 = 01	V _{CC} = 5.5V, R3, R4, R6 bus lines loaded with 3 kΩ, R3 load cap = 1000 pF, L3 toggling, SLR = L(1Mbps)		320	500	mW
		V _{CC} = 5.5V, R3, R4, R6 bus lines loaded with 3 kΩ, R3 load cap = 2500 pF, L3 toggling, SLR = H(250kbps)		240	350	

8.5 Electrical Characteristics(Static)

Over operating free-air temperature range (unless otherwise noted). All typical values are at 25°C and supply voltage of $V_{CC} = 5\text{ V}$, unless otherwise noted.

Symbol	Parameter	Conditions	Min	Typ	Max	Unit
Supply						
$V_{UVD(RIS)VCC}$	Rising under-voltage threshold on VCC			2.5	2.8	V
$V_{UVD(FAL)VCC}$	Falling under-voltage threshold on VCC		1.9	2.3		V
$V_{UVD(HYS)VCC}$	Hysteresis on under-voltage of VCC		100	200		mV
$I_{CC(SHDN)}$	Supply current in shutdown mode	$V_{CC} = 4.5\text{ V to }5.5\text{ V}$, nSHDN = GND, All other logic input pins floating, no load on bus, $T_A \leq 125\text{ }^\circ\text{C}$		0.5	15	μA
		$V_{CC} = 3\text{ V to }3.6\text{ V}$, nSHDN = GND, All other logic input pins floating, no load on bus, $T_A \leq 125\text{ }^\circ\text{C}$		0.4	12	μA
		$V_{CC} = 4.5\text{ V to }5.5\text{ V}$, nSHDN = GND, All other logic input pins floating, no load on bus, $T_A \leq 105\text{ }^\circ\text{C}$		0.5	12	μA
		$V_{CC} = 3\text{ V to }3.6\text{ V}$, nSHDN = GND, All other logic input pins floating, no load on bus, $T_A \leq 105\text{ }^\circ\text{C}$		0.4	10	μA

8.5 Electrical Characteristics(Static) (continued)

Over operating free-air temperature range (unless otherwise noted). All typical values are at 25°C and supply voltage of $V_{CC} = 5\text{ V}$, unless otherwise noted.

Symbol	Parameter	Conditions	Min	Typ	Max	Unit
$I_{CC(485)}$	Supply current (quiescent), $V_{CC} = 4.5\text{ V to }5.5\text{ V}$, TERM_RX = Floating or low, SLR = X	Driver and receiver enabled, DIR = V_{CC} , MODE1, MODE0 = 11 (Full duplex), No load		2	3.4	mA
		Driver enabled, receiver disabled, DIR = V_{CC} , MODE1, MODE0 = 10 (Half duplex), No load		2	2.8	mA
		Driver disabled, receiver enabled, DIR = GND, MODE1, MODE0 = 10 (Half duplex), No load		1.65	2.5	mA
	Supply current (quiescent), $V_{CC} = 3\text{ V to }3.6\text{ V}$, TERM_RX = Floating or low, SLR = X	Driver and receiver enabled, DIR = V_{CC} , MODE1, MODE0 = 11 (Full duplex), No load		1.8	2.8	mA
		Driver enabled, receiver disabled, DIR = V_{CC} , MODE1, MODE0 = 10 (Half duplex), No load		1.8	2.3	mA
		Driver disabled, receiver enabled, DIR = GND, MODE1, MODE0 = 10 (Half duplex), No load		1.3	2.1	mA
$I_{CC(485)RT}$	Supply current in RS-485 receiver termination mode	Receiver enabled with termination ON; MODE1, MODE0 = 11 (full duplex), DIR = GND, TERM_RX = V_{CC}		2.6	3.8	mA
$I_{CC(232)}$	Supply current in RS-232 mode	MODE1, MODE0 = 01, nSHDN = V_{CC} ; other logic inputs floating, No load		4.5	9.3	mA
$I_{CC(232)LB}$	Supply current in RS-232 loopback mode	MODE1 = MODE0 = 00; L3 = L4 = L6 = static logic high, $-40\text{ °C} \leq T_A \leq 125\text{ °C}$, No extra load on RS-232 drivers or on logic output		22	31	mA

8.5 Electrical Characteristics(Static) (continued)

Over operating free-air temperature range (unless otherwise noted). All typical values are at 25°C and supply voltage of $V_{CC} = 5\text{ V}$, unless otherwise noted.

Symbol	Parameter	Conditions	Min	Typ	Max	Unit
Integrate termination resistor in RS-485 mode						
$R_{\text{TERM(RX)}}$	120 Ω termination across receiver output R3/R4 terminals	MODE1, MODE0 = 11 (Full duplex); TERM_RX = V_{CC} , $V_{R3R4} = 2\text{ V}$, $V_{R4} = -7\text{ V}$, 0 V, 10 V, See Figure 9-9	102	120	138	Ω
Logic						
I_{IN}	Input current	$0\text{ V} \leq V_{\text{IN}} \leq V_{CC}$, (L3, L4, L6, DIR, nSHDN, SLR, TERM_RX, MODE1, MODE0)	-20		8	μA
V_{IH}	Input High Voltage	$3\text{ V} \leq V_{CC} \leq 5.5\text{ V}$			$0.7V_{CC}$	V
V_{IL}	Input low Voltage		$0.3V_{CC}$			V
RS-485 Driver						
$ V_{\text{OD}} $	Driver differential output voltage magnitude	$R_L = 60\ \Omega$, $-7\text{ V} \leq V_{\text{TEST}} \leq 12\text{ V}$, See Figure 9-1	1.5	3.3		V
		$R_L = 60\ \Omega$, $-7\text{ V} \leq V_{\text{TEST}} \leq 12\text{ V}$, $4.5\text{ V} \leq V_{CC} \leq 5.5\text{ V}$ See Figure 9-1	2.1	3.3		V
		$R_L = 100\ \Omega$, See Figure 9-2	2	3.9		V
		$R_L = 54\ \Omega$, $4.5\text{ V} \leq V_{CC} \leq 5.5\text{ V}$ See Figure 9-2	2.1	3.3		V
		$R_L = 54\ \Omega$, See Figure 9-2	1.5	3.3		V
$\Delta V_{\text{OD}} $	Change in magnitude of driver differential output voltage	$R_L = 54\ \Omega$ or $100\ \Omega$ See Figure 9-2	-50		50	mV
V_{OC}	Common-mode output voltage	$R_L = 54\ \Omega$ or $100\ \Omega$ See Figure 9-2		$V_{CC}/2$	3	V
$\Delta V_{\text{OC(SS)}}$	Change in steady-state common-mode output voltage	$R_L = 54\ \Omega$ or $100\ \Omega$ See Figure 9-2	-50		50	mV
I_{OS}	Short-circuit output current (Note 2)	DIR = V_{CC} , $-7\text{ V} \leq (V_{R2}$ or $V_{R1}) \leq 12\text{ V}$, or R1 shorted to R2	-250		250	mA

8.5 Electrical Characteristics(Static) (continued)

Over operating free-air temperature range (unless otherwise noted). All typical values are at 25°C and supply voltage of $V_{CC} = 5\text{ V}$, unless otherwise noted.

Symbol	Parameter	Conditions	Min	Typ	Max	Unit
I_{OZD}	Driver High impedance output leakage current on R1 and R2 in Full duplex mode	MODE1, MODE0 = 11, TERM_RX = GND, DIR = GND, $V_{CC} = \text{GND}$ or 5.5V, $V_O = -7\text{V}, +12\text{V}$	-125		125	μA
RS-485 Receiver						
I_I	Bus input current (termination disabled)	Half and full duplex modes, DIR = GND, $V_{CC} = 0\text{V}$ or 5.5V, $V_I = 12\text{V}$		75	125	μA
		Half and full duplex modes, DIR = GND, $V_{CC} = 0\text{V}$ or 5.5V, $V_I = -7\text{V}$	-450	-50		μA
I_{RXT}	Receiver bus input leakage current with termination enabled	Full duplex mode, $V_{CC} = 5.5\text{ V}$, TERM_RX = V_{CC} , $V_I = -7$ to 12V	-450		325	μA
V_{TH+}	Positive-going input threshold voltage (Note 1)	Over common-mode range of -7V to 12V		100	200	mV
V_{TH-}	Negative-going input threshold voltage (Note 1)		-200	-100		mV
V_{HYS}	Input hysteresis			200		mV
$C_{A,B}$	Input differential capacitance	Measured between R3 and R4, $f = 1\text{ MHz}$		45		pF
V_{OH}	Output high voltage L2 pin	$I_{OH} = -4\text{ mA}$	$V_{CC}-0.4$	$V_{CC}-0.2$		V
V_{OL}	Output low voltage L2 pin	$I_{OL} = 4\text{ mA}$		0.2	0.4	V
I_{OZ}	Output high-impedance current, L2 pin	$V_O = 0\text{ V}$ or V_{CC} , DIR = V_{CC} , MODE1, MODE0= 10 (half duplex mode)	-1		1	μA

8.5 Electrical Characteristics(Static) (continued)

Over operating free-air temperature range (unless otherwise noted). All typical values are at 25°C and supply voltage of $V_{CC} = 5\text{ V}$, unless otherwise noted.

Symbol	Parameter	Conditions	Min	Typ	Max	Unit
RS-232 Driver						
V_{OH}	High-level output voltage	All DOUT (R3, R4, R6) at $R_L = 3\text{ k}\Omega$ to GND, DIN (L3, L4, L6) = GND; $V_{CC} = 3\text{V to } 3.6\text{V}$	4.2	5.5	7	V
		All DOUT (R3, R4, R6) at $R_L = 3\text{ k}\Omega$ to GND, DIN (L3, L4, L6) = GND; $V_{CC} = 4.5\text{V to } 5.5\text{V}$	6.3	8.5	10	V
V_{OL}	Low-level output voltage	All DOUT (R3, R4, R6) at $R_L = 3\text{ k}\Omega$ to GND, DIN (L3, L4, L6) = V_{CC} ; $V_{CC} = 3\text{V to } 3.6\text{V}$	-7	-5.5	-4.2	V
		All DOUT (R3, R4, R6) at $R_L = 3\text{ k}\Omega$ to GND, DIN (L3, L4, L6) = V_{CC} ; $V_{CC} = 4.5\text{V to } 5.5\text{V}$	-10	-8.5	-6.3	V
I_{OS}	Short-circuit output current (Note 2)	$V_{CC} = 3.6\text{ V}, V_O = 0\text{V}$		± 35	± 60	mA
		$V_{CC} = 5.5\text{ V}, V_O = 0\text{V}$		± 35	± 60	mA
R_O	Output resistance on R3, R4, R6 pins	$V_{CC} = 0\text{V}, V_+ = 0\text{V},$ and $V_- = 0\text{V}, V_O = \pm 2\text{V}$	300	10M		Ω
I_{OFF}	Output leakage current on R3, R4, R6 pins	nSHDN = GND, $V_{CC} = 3\text{V to } 3.6\text{ V}, V_O = \pm 12\text{V}, T_A = 25^\circ\text{C}$	-125		125	μA
		nSHDN = GND, $V_{CC} = 4.5\text{V to } 5.5\text{ V}, V_O = \pm 10\text{V}, T_A = 25^\circ\text{C}$	-125		125	μA
RS-232 Receiver						
V_{OH}	High-level output voltage on L1/L2/L5/L7/L8 pins	$I_{OH} = -1.5\text{ mA}$	$V_{CC}-0.5$			V
V_{OL}	Low-level output voltage on L1/L2/L5/L7/L8 pins	$I_{OL} = 2\text{ mA}$			0.4	V
V_{TH+}	Positive-going input threshold voltage on RS-232 receiver inputs (R1, R2, R5, R7, R8) (Note 1)	$V_{CC} = 3.3\text{V}$		1.4	2.4	V
		$V_{CC} = 5\text{V}$		2	2.4	V

8.5 Electrical Characteristics(Static) (continued)

Over operating free-air temperature range (unless otherwise noted). All typical values are at 25°C and supply voltage of $V_{CC} = 5\text{ V}$, unless otherwise noted.

Symbol	Parameter	Conditions	Min	Typ	Max	Unit
V_{TH-}	Negative-going input threshold voltage on RS-232 receiver inputs (R1, R2, R5, R7, R8) (Note 1)	$V_{CC} = 3.3\text{V}$	0.6	1.1		V
		$V_{CC} = 5\text{V}$	0.8	1.6		V
V_{HYS}	Input hysteresis on receiver inputs ($V_{TH+} - V_{TH-}$)			0.4		V
I_{OFF}	Output leakage current on receiver output L1/L2/L5/L7/L8 pins	nSHDN = 0V		±0.05	±10	µA
R_I	Input resistance on receiver input pins	$-15\text{ V} \leq V_I \leq 15\text{ V}$	3	5	7	kΩ
Thermal Protection						
T_{SD}	Thermal shutdown threshold	Temperature rising	150	170		°C
T_{HYS}	Thermal shutdown hysteresis			10		°C

Note 1: V_{TH+} is assured to be at least V_{HYS} higher than V_{TH-} .

Note 2: Short-circuit durations should be controlled to prevent exceeding the device absolute power dissipation ratings, and not more than one output should be shorted at a time.

8.6 Electrical Characteristics (Dynamic)—RS-485_250kbps

250kbps (SLR = V_{CC}) over recommended operating conditions. All typical values are at 25°C and supply voltage of V_{CC} = 5V, unless otherwise noted. (Note 1)

Symbol	Parameter	Conditions	Min	Typ	Max	Unit	
Driver							
t _R , t _F	Driver differential output rise/fall time	R _L = 54 Ω, C _L = 50 pF, see Figure 9-3	V _{CC} = 3 to 3.6 V, Typical at 3.3 V	300	390	1200	ns
			V _{CC} = 4.5 to 5.5 V, Typical at 5 V	400	600	1200	ns
t _{PHL} , t _{PLH}	Driver propagation delay time		V _{CC} = 3 to 3.6 V, Typical at 3.3 V		365	720	ns
			V _{CC} = 4.5 to 5.5 V, Typical at 5 V		435	770	ns
t _{SK(P)}	Driver differential output pulse skew, t _{PHL} - t _{PLH}		V _{CC} = 3 to 3.6 V, Typical at 3.3 V		3	70	ns
			V _{CC} = 4.5 to 5.5 V, Typical at 5 V		2	70	ns
t _{PHZ} , t _{PLZ}	Disable time	MODE1, MODE0 = 10 (half duplex) or 11 (full duplex), see Figure 9-4 and Figure 9-5			300	ns	
t _{PZH} , t _{PZL}	Enable time	MODE1, MODE0 = 11 (full duplex): receiver enabled, see Figure 9-4 and Figure 9-5			10	μs	
Receiver							
t _R , t _F	Receiver output rise/fall time	C _L = 15 pF, see Figure 9-6		8	20	ns	
t _{PHL} , t _{PLH}	Receiver propagation delay time			640	1200	ns	
t _{SK(P)}	Receiver output pulse skew, t _{PHL} - t _{PLH}			2	45	ns	
t _{PHZ} , t _{PLZ}	Disable time in half duplex mode	MODE1, MODE0 = 10, TERM_RX = V _{CC} , see Figure 9-7			40	ns	
t _{PZH} , t _{PZL}	Enable time in half duplex mode				150	ns	
t _{PSH} , t _{PSL}	Enable time from shutdown with TX disabled in full duplex mode	DIR = 0V; MODE1, MODE0 = 11, see Figure 9-8		7	16	μs	

Note 1: R3, R4 are receiver inputs, R2, R1 are driver outputs in Full duplex mode.

8.7 Electrical Characteristics (Dynamic)—RS-485_20Mbps

20Mbps (SLR = GND) over recommended operating conditions. All typical values are at 25°C and supply voltage of $V_{CC} = 5V$, unless otherwise noted. (Note 1)

Symbol	Parameter	Conditions	Min	Typ	Max	Unit	
Driver							
t_R, t_F	Driver differential output rise/fall time	$R_L = 54 \Omega$, $C_L = 50 \text{ pF}$, see Figure 9-3	$V_{CC} = 3 \text{ to } 3.6V$, Typical at 3.3V	4	7.5	15	ns
			$V_{CC} = 4.5 \text{ to } 5.5V$, Typical at 5V	4	7	15	ns
t_{PHL}, t_{PLH}	Driver propagation delay time		$V_{CC} = 3 \text{ to } 3.6V$, Typical at 3.3V		12	58	ns
			$V_{CC} = 4.5 \text{ to } 5.5V$, Typical at 5V		10	46	ns
$t_{SK(P)}$	Driver differential output pulse skew, $ t_{PHL} - t_{PLH} $		$V_{CC} = 3 \text{ to } 3.6V$, Typical at 3.3V		0.4	3.5	ns
			$V_{CC} = 4.5 \text{ to } 5.5V$, Typical at 5V		0.2	3.5	ns
t_{PHZ}, t_{PLZ}	Disable time	MODE1, MODE0 = 10 (half duplex) or 11 (full duplex), see Figure 9-4 and Figure 9-5			90	ns	
t_{PZH}, t_{PZL}	Enable time	MODE1, MODE0 = 11 (full duplex): receiver enabled, see Figure 9-4 and Figure 9-5			9	μs	
Receiver							
t_R, t_F	Receiver output rise/fall time	$C_L = 15 \text{ pF}$, see Figure 9-6		4.5	10	ns	
t_{PHL}, t_{PLH}	Receiver propagation delay time			14	70	ns	
$t_{SK(P)}$	Receiver output pulse skew, $ t_{PHL} - t_{PLH} $				10	ns	
t_{PHZ}, t_{PLZ}	Disable time in half duplex mode	MODE1, MODE0 = 10, TERM_RX = V_{CC} , see Figure 9-7		8	80	ns	
t_{PZH}, t_{PZL}	Enable time in half duplex mode (includes driver disable time as per setup)			96	160	ns	
t_{PSH}, t_{PSL}	Enable time from shutdown with TX disabled in full duplex mode	DIR = 0V; MODE1, MODE0 = 11, see Figure 9-8		6.6	15	μs	

Note 1: R3, R4 are receiver inputs, R2, R1 are driver outputs in Full duplex mode.

8.9 Electrical Characteristics (Dynamic)—RS-232_250kbps

over recommended ranges of supply voltage and operating free-air temperature. All typical values are at 25°C and supply voltage of $V_{CC} = 3.3V$ or $5V$, unless otherwise noted. (Note 1)

Symbol	Parameter	Conditions	Min	Typ	Max	Unit
Driver						
DR_{MAX}	Maximum data rate	$R_L = 3k\Omega$, $C_L = 2500$ pF, one DOUT switching, see Figure 9-10	250			kbps
t_{PLH} , t_{PHL}	Transmitter propagation delay	$R_L = 3k\Omega$ to $7k\Omega$, $C_L = 150$ pF to 2500 pF, see Figure 9-10			2	μs
$t_{SK(P)}$	Transmitter Pulse skew				600	ns
SR_{TR}	Transition region Slew rate	$V_{CC} = 3.3V \pm 10\%$ or $5V \pm 10\%$, $R_L = 3k\Omega$ to $7k\Omega$, $C_L = 150$ pF to 1000 pF, see Figure 9-11	6		30	V/ μs
		$V_{CC} = 3.3V \pm 10\%$ or $5V \pm 10\%$, $R_L = 3k\Omega$ to $7k\Omega$, $C_L = 150$ pF to 2500 pF, see Figure 9-11	4		30	V/ μs
Receiver						
t_{PLH}	Propagation delay time, low- to high-level output	$C_L = 150$ pF, see Figure 9-12		150	550	ns
		$C_L = 15$ pF, see Figure 9-12		110	520	ns
t_{PHL}	Propagation delay time, high- to low-level output	$C_L = 150$ pF, see Figure 9-12		150	550	ns
		$C_L = 15$ pF, see Figure 9-12		110	520	ns
$t_{R(232)}$, $t_{F(232)}$	Rise/fall time (receiver buffer output)	$C_L = 150$ pF, see Figure 9-12		20	50	ns
		$C_L = 15$ pF, see Figure 9-12		7	13	ns
t_{EN}	Output enable time	$C_L = 150$ pF, $R_L = 3k\Omega$, See Figure 9-13		2.8	14	μs
t_{DIS}	Output disable time			135	400	ns
$t_{SK(P)}$	Receiver output pulse skew, $ t_{PHL} - t_{PLH} $	$C_L = 150$ pF, see Figure 9-12			125	ns
		$C_L = 15$ pF, see Figure 9-12			125	ns

Note 1: Test conditions are $C1-C4 = 0.1\mu F$ at $V_{CC} = 3.3V \pm 0.3V$ and $V_{CC} = 5V \pm 0.5V$.

8.10 Electrical Characteristics (Dynamic)—RS-232_1Mbps

over recommended ranges of supply voltage and operating free-air temperature. All typical values are at 25°C and supply voltage of $V_{CC} = 3.3V$ or $5V$, unless otherwise noted. (Note 1)

Symbol	Parameter	Conditions	Min	Typ	Max	Unit
Driver						
DR _{MAX}	Maximum data rate	$R_L = 3k\Omega$, $C_L = 250$ pF, $V_{CC} = 3$ to $3.6V$, one DOUT switching, see Figure 9-10	1000			kbps
		$R_L = 3k\Omega$, $C_L = 1000$ pF, $V_{CC} = 4.5$ to $5.5V$, one DOUT switching, see Figure 9-10	1000			kbps
t _{PLH} , t _{PHL}	Transmitter propagation delay	$R_L = 3k\Omega$ to $7k\Omega$, $C_L = 150$ pF to 1000 pF, see Figure 9-11			800	ns
t _{SK(P)}	Transmitter Pulse skew				150	ns
SR _{TR}	Transition region Slew rate	$V_{CC} = 4.5$ to $5.5V$, $R_L = 3k\Omega$ to $7k\Omega$, $C_L = 150$ pF to 1000 pF, see Figure 9-11	18		150	V/ μ s
		$V_{CC} = 3$ to $3.6V$, $R_L = 3k\Omega$ to $7k\Omega$, $C_L = 150$ pF to 1000 pF, see Figure 9-11	15		150	V/ μ s
Receiver						
t _{PLH}	Propagation delay time, low- to high-level output	$C_L = 150$ pF, see Figure 9-12		150	550	ns
		$C_L = 15$ pF, see Figure 9-12		110	520	ns
t _{PHL}	Propagation delay time, high- to low-level output	$C_L = 150$ pF, see Figure 9-12		150	550	ns
		$C_L = 15$ pF, see Figure 9-12		110	520	ns
t _{R(232)} , t _{F(232)}	Rise/fall time (receiver buffer output)	$C_L = 150$ pF, see Figure 9-12		20	50	ns
		$C_L = 15$ pF, see Figure 9-12		7	13	ns
t _{EN}	Output enable time	$C_L = 150$ pF, $R_L = 3k\Omega$, See Figure 9-13		2.8	14	μ s
t _{DIS}	Output disable time			135	400	ns
t _{SK(P)}	Receiver output pulse skew, $ t_{PHL} - t_{PLH} $	$C_L = 150$ pF, see Figure 9-12			125	ns
		$C_L = 15$ pF, see Figure 9-12			125	ns

Note 1: Test conditions are $C1-C4 = 0.1\mu F$ at $V_{CC} = 3.3V \pm 0.3V$ and $V_{CC} = 5V \pm 0.5V$.

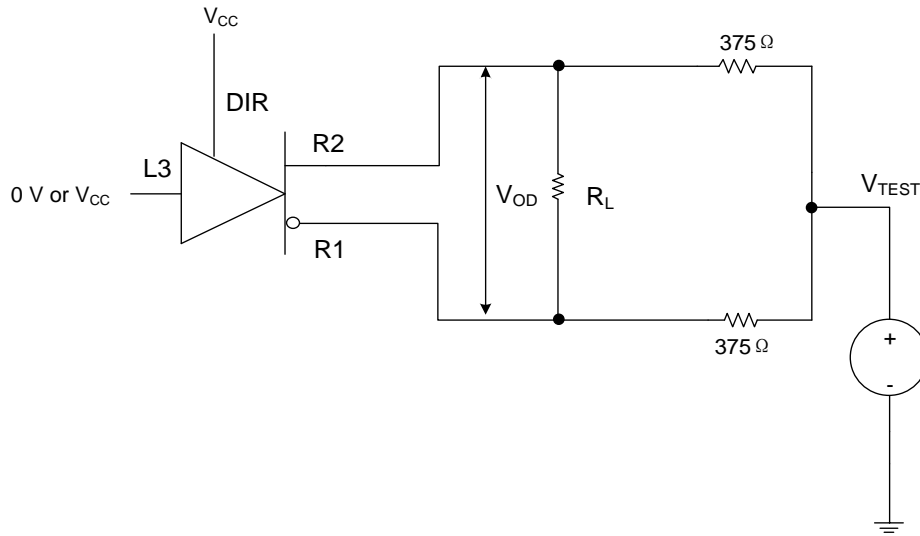
9 Parameter Measurement Information


Figure 9-1. Measurement of RS-485 Driver Differential Output Voltage With Common-Mode Load

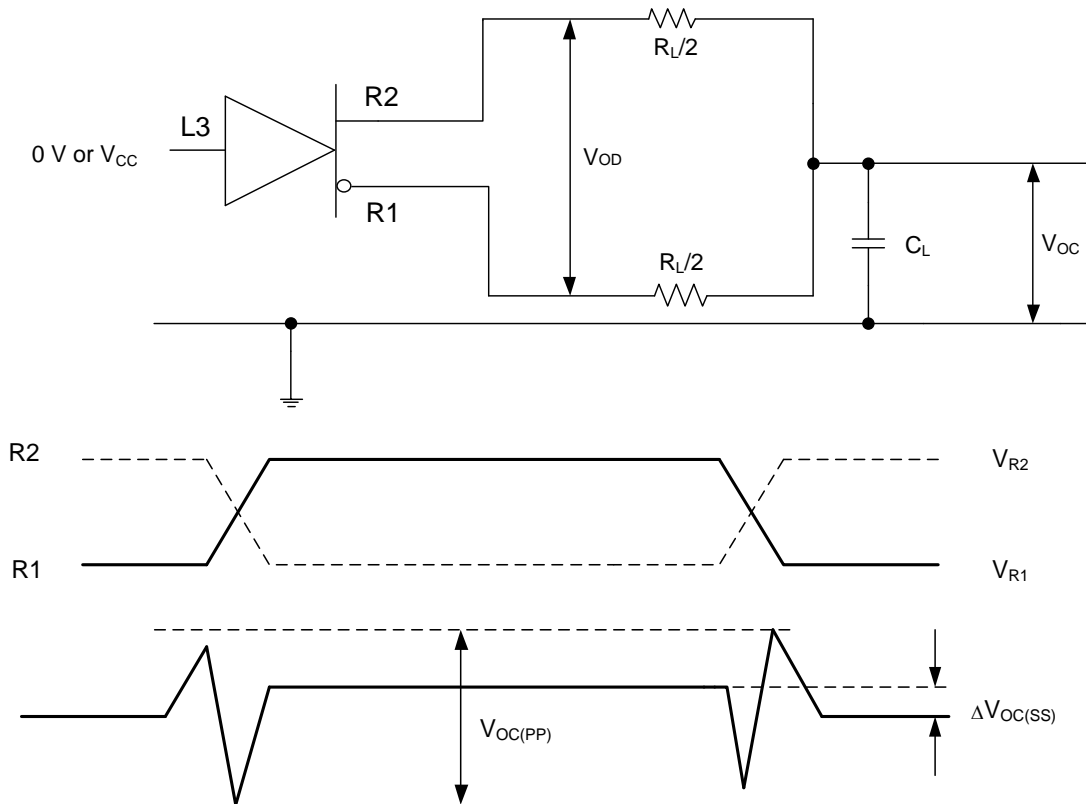


Figure 9-2. Measurement of RS-485 Driver Differential and Common-Mode Output With RS-485 Load

9 Parameter Measurement Information (continued)

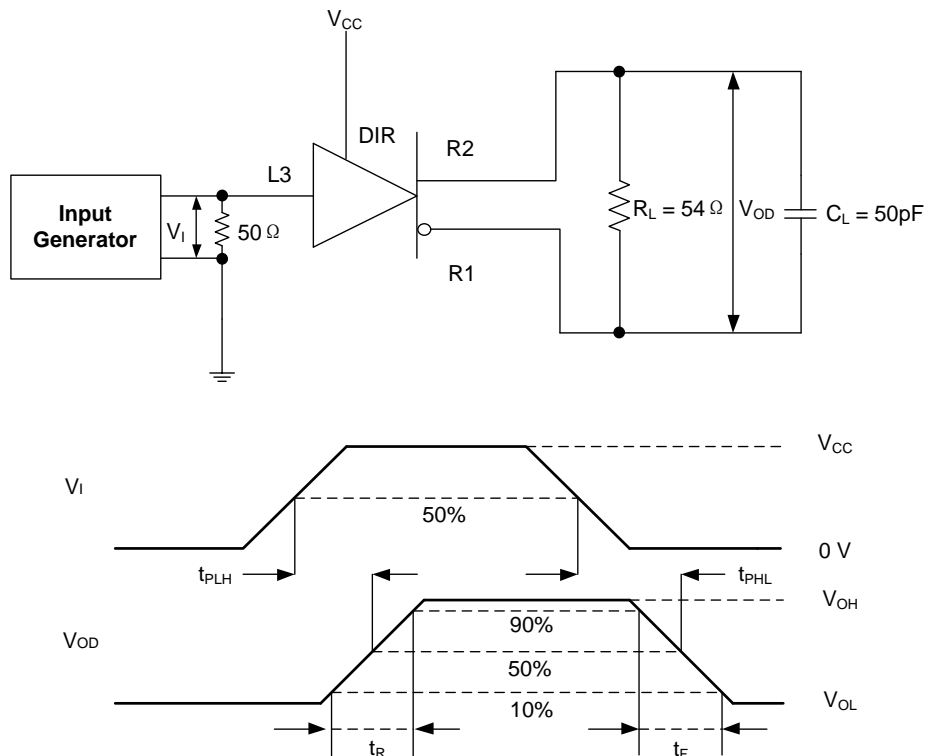


Figure 9-3. Measurement of RS-485 Driver Differential Output Rise and Fall Times and Propagation Delays

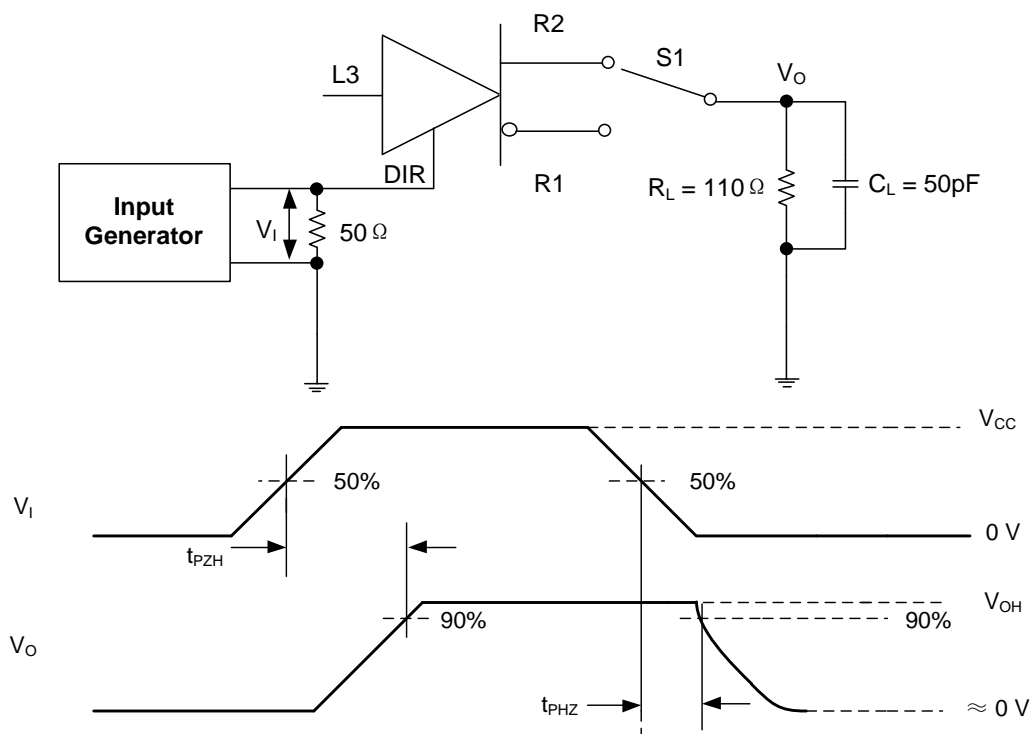


Figure 9-4. Measurement of RS-485 Driver Enable and Disable Times With Active High Output and Pull-Down Load

9 Parameter Measurement Information (continued)

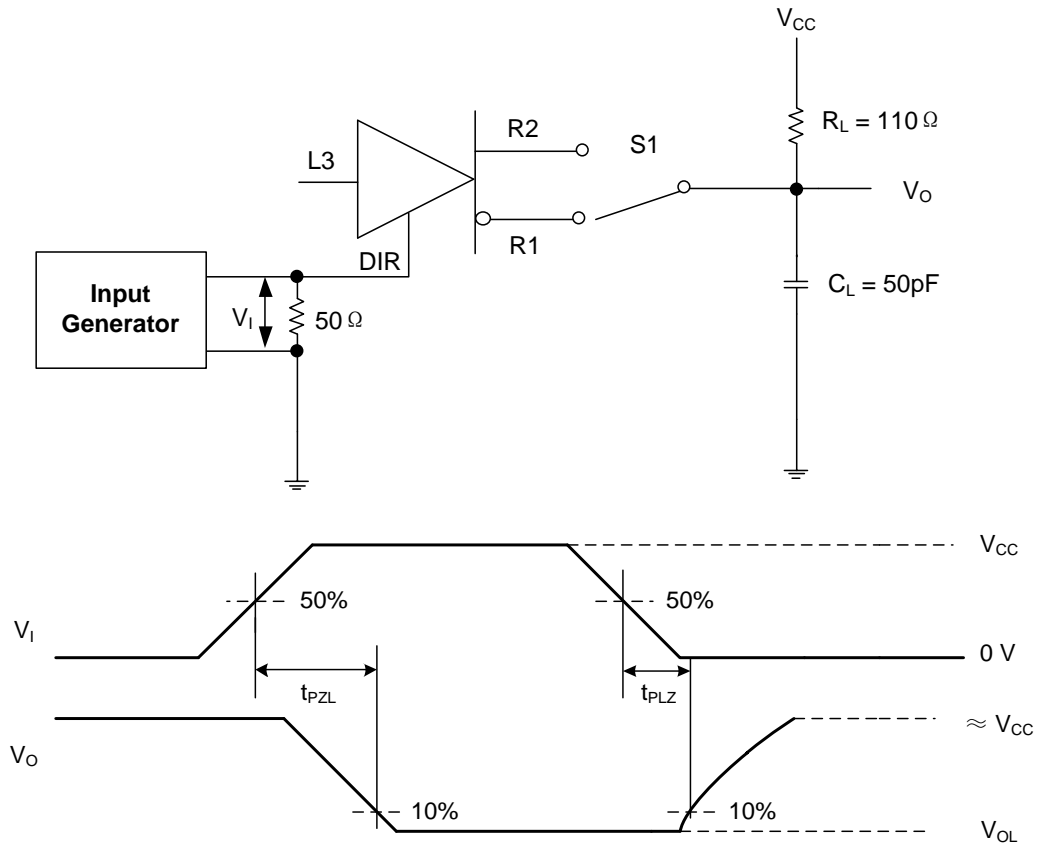
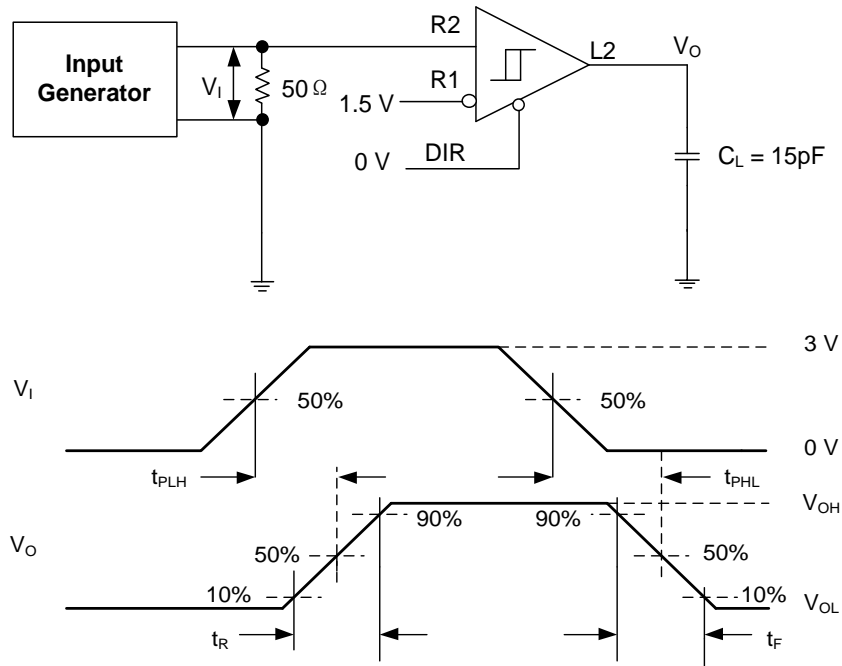


Figure 9-5. Measurement of RS-485 Driver Enable and Disable Times with Active Low Output and Pull-up Load



Note 1: Input terminals are R1 and R2 in half duplex mode, R3 and R4 in Full duplex mode

Figure 9-6. Measurement of RS-485 Receiver Output Rise and Fall Times and Propagation Delays

9 Parameter Measurement Information (continued)

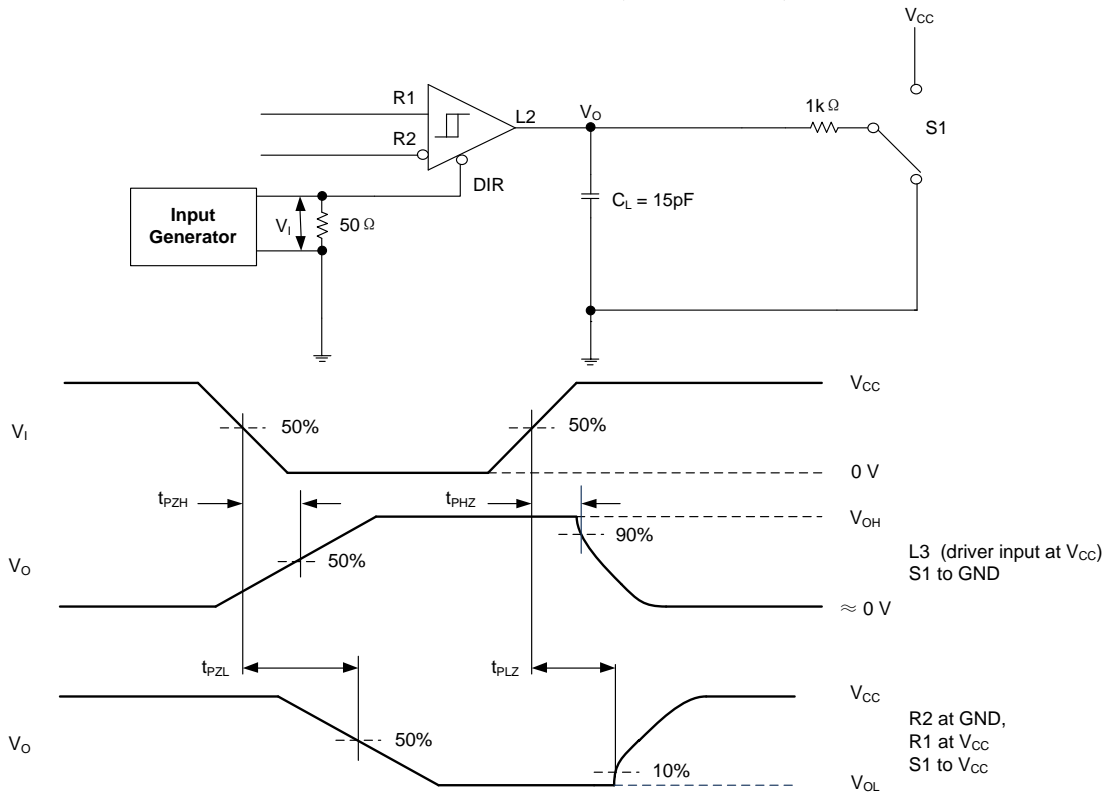


Figure 9-7. Measurement of RS-485 Receiver Enable and Disable Times in Half Duplex Mode

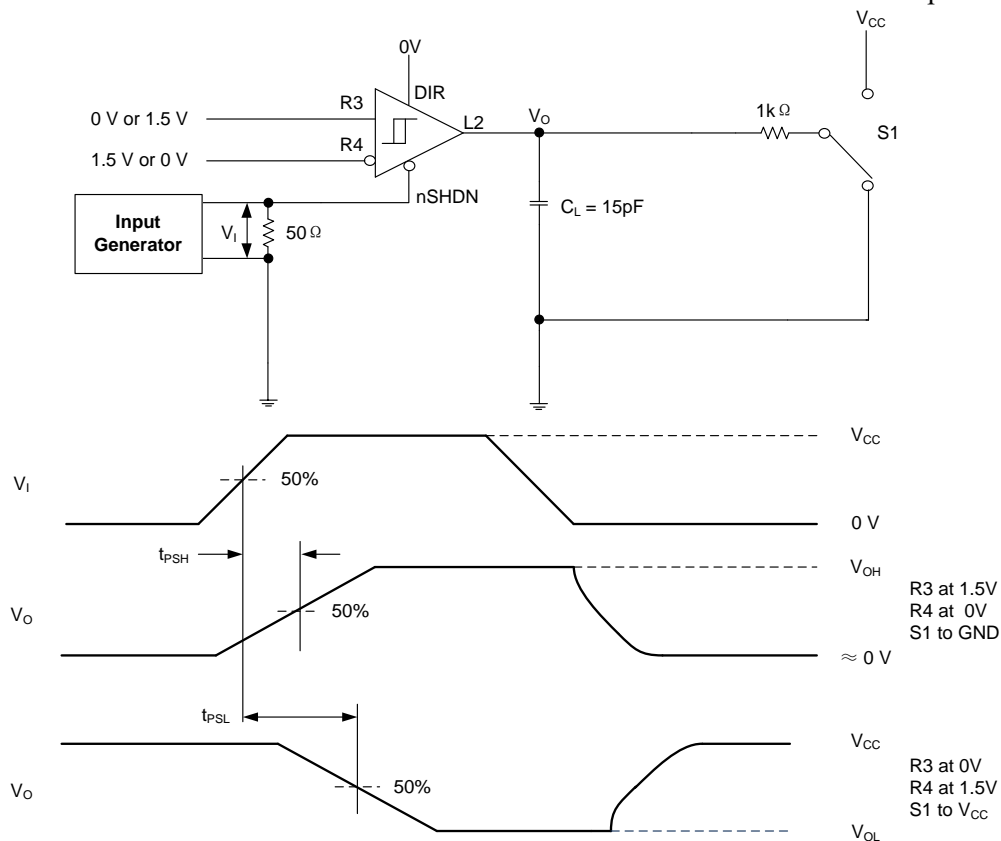


Figure 9-8. Measurement of RS-485 Receiver Enable Time from Shutdown with TX Disabled: Full Duplex Mode

9 Parameter Measurement Information(continued)

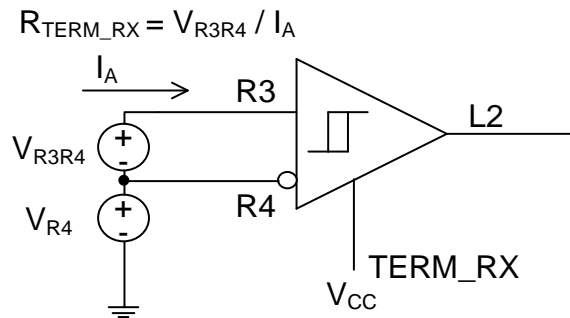
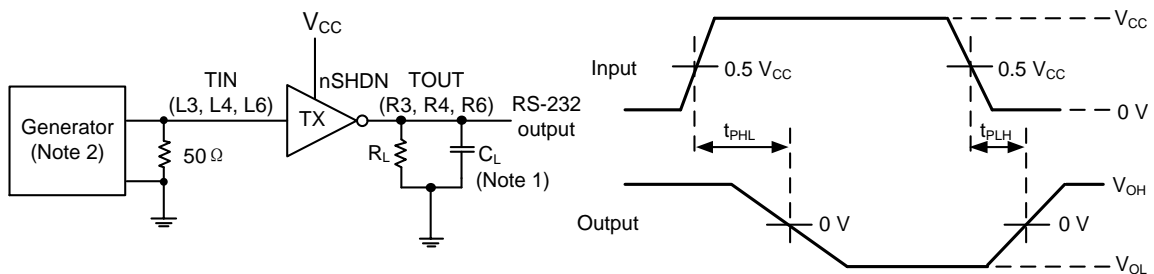


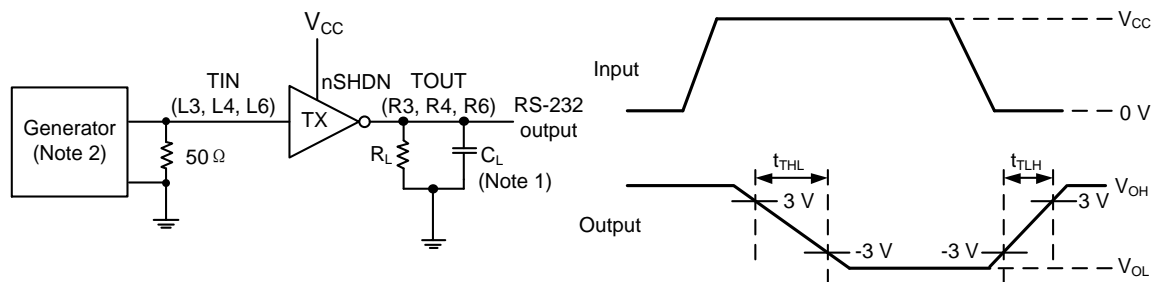
Figure 9-9. Termination Resistor Measurement



Note 1: C_L includes probe and jig capacitance.

Note 2: The pulse generator has the following characteristics: PRR = 250 kbps and 1 Mbit/s, 50% duty cycle, $t_R \leq 10$ ns, $t_F \leq 10$ ns.

Figure 9-10. RS-232 Driver Prop Delay, Pulse Skew



Note 1: C_L includes probe and jig capacitance.

Note 2: The pulse generator has the following characteristics: PRR = 250 kbps and 1 Mbit/s, 50% duty cycle, $t_R \leq 10$ ns, $t_F \leq 10$ ns.

Note 3: $SR = 6$ V / (t_{THL} or t_{TLH}).

Figure 9-11. RS-232 Driver Slew Rate

9 Parameter Measurement Information (continued)

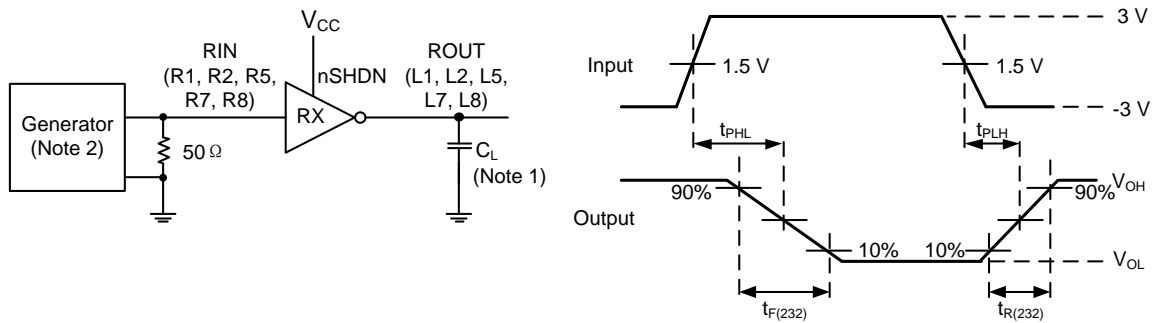
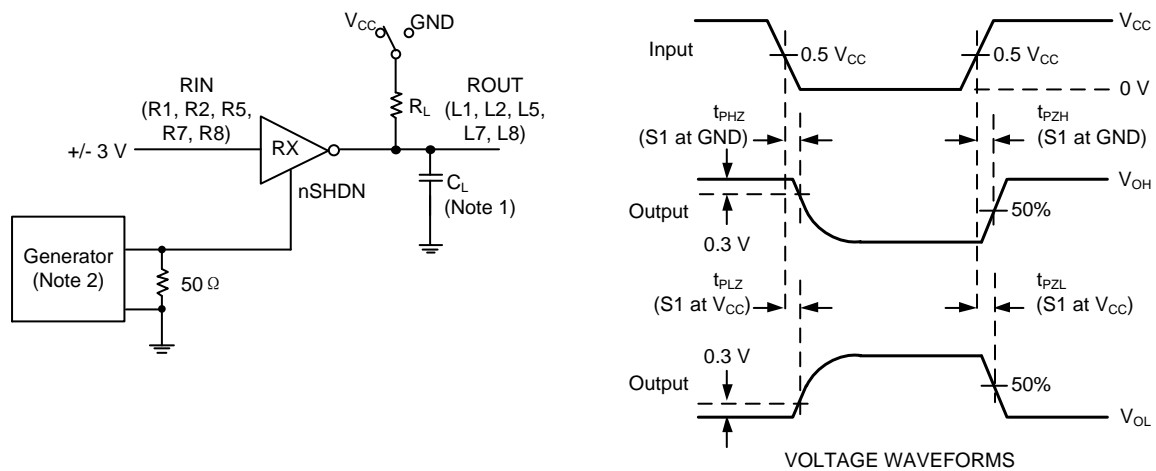


Figure 9-12. RS-232 Receiver Propagation Delay, Pulse Skew



Note 1: C_L includes probe and jig capacitance.

Note 2: The pulse generator has the following characteristics: 50% duty cycle, $t_R \leq 10$ ns, $t_F \leq 10$ ns.

Note 3: t_{PLZ} and t_{PHZ} are same as t_{DIS} , t_{PZL} and t_{PZH} are same as t_{EN} .

Figure 9-13. RS-232 Receiver Enable and Disable Time

10 Detailed Description

10.1 Overview

The UM3035B is an advanced and robust multiprotocol transceiver supporting RS-232, RS-422 and RS-485 physical layers in a 40-pin 6×6 QFN package. Integrated cable termination and configuration modes allow RS-232, RS-422 and RS-485 protocols to be used interchangeably over a single cable or connector with no additional components. The device has three transmitters and five receivers to enable 3T5R RS-232 port. The device also integrates one transmitter and one receiver to enable half and full duplex RS-485 port. The device also integrates one transmitter and one receiver to enable half and full duplex RS-485 port.

The device has SLR pin which allows it to be used for two different maximum speed settings for RS-232 and for RS-485. This is beneficial as customers can qualify one device and use it in two separate end-applications.

10.2 Functional Block Diagram

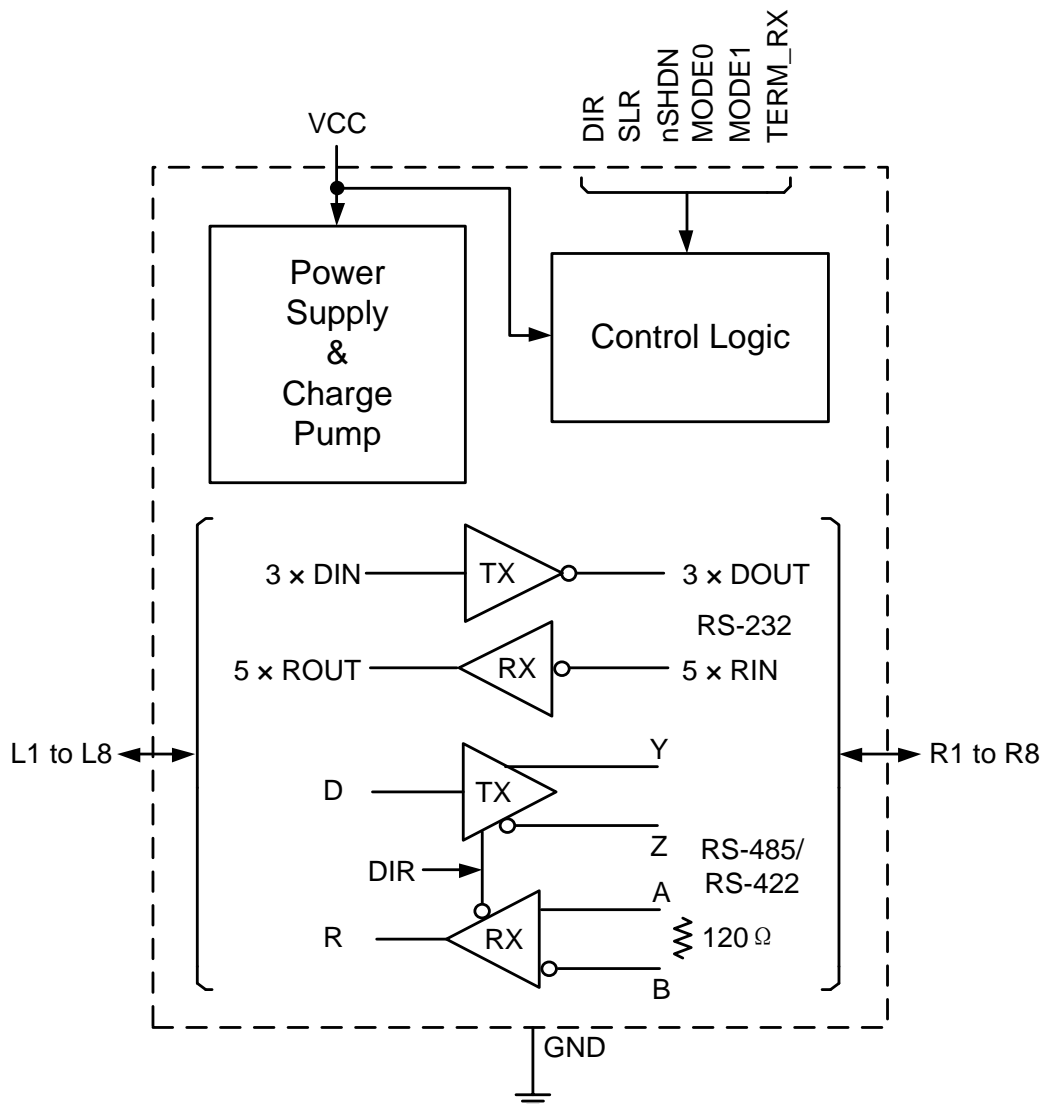
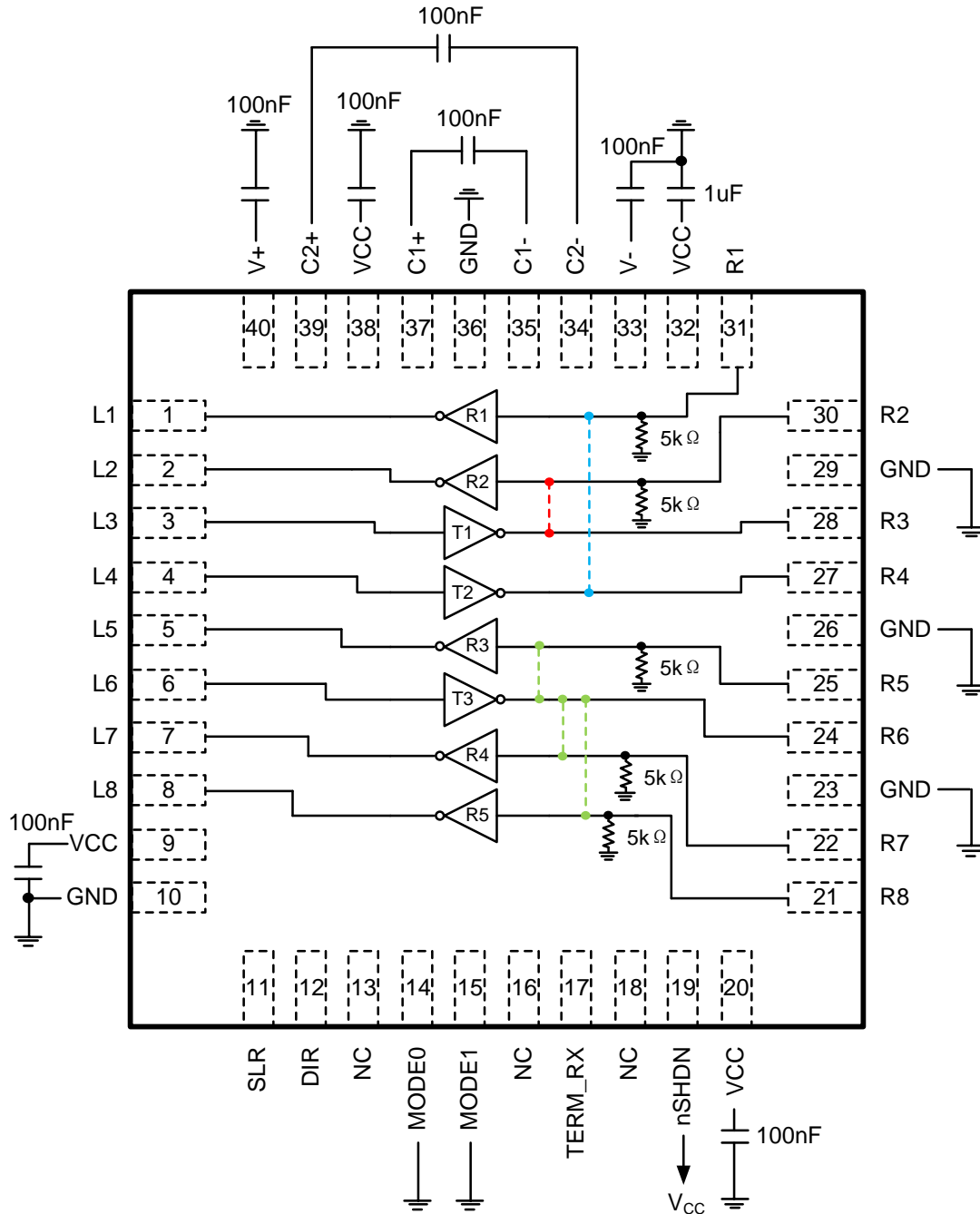


Figure 10-1. UM3035B Block Diagram

10.3 Device Functional Modes

The UM3035B is a highly integrated and robust multiprotocol transceiver supporting RS-232, RS-422 and RS-485 physical layers. The device features 2 mode selection pins (MODE1, MODE0) to enable switching between four different operating modes (RS-232 Loopback Mode, RS-232 3T5R Mode, RS485 Half duplex and RS-422 Full duplex mode).

10.3.1 RS-232 Loopback Mode: 00 (MODE1, MODE0) (Note 1)



Note 1: L3 reflects on L2, R2, R3 (red); L4 reflects on L1, R1, R4 (blue); L6 reflects on L5, L7, L8, R5, R6, R7, R8 (green).

Figure 10-2. UM3035B RS-232 Loopback Mode

10.3.3 RS-485 Half Duplex Mode: 10 (MODE1, MODE0)

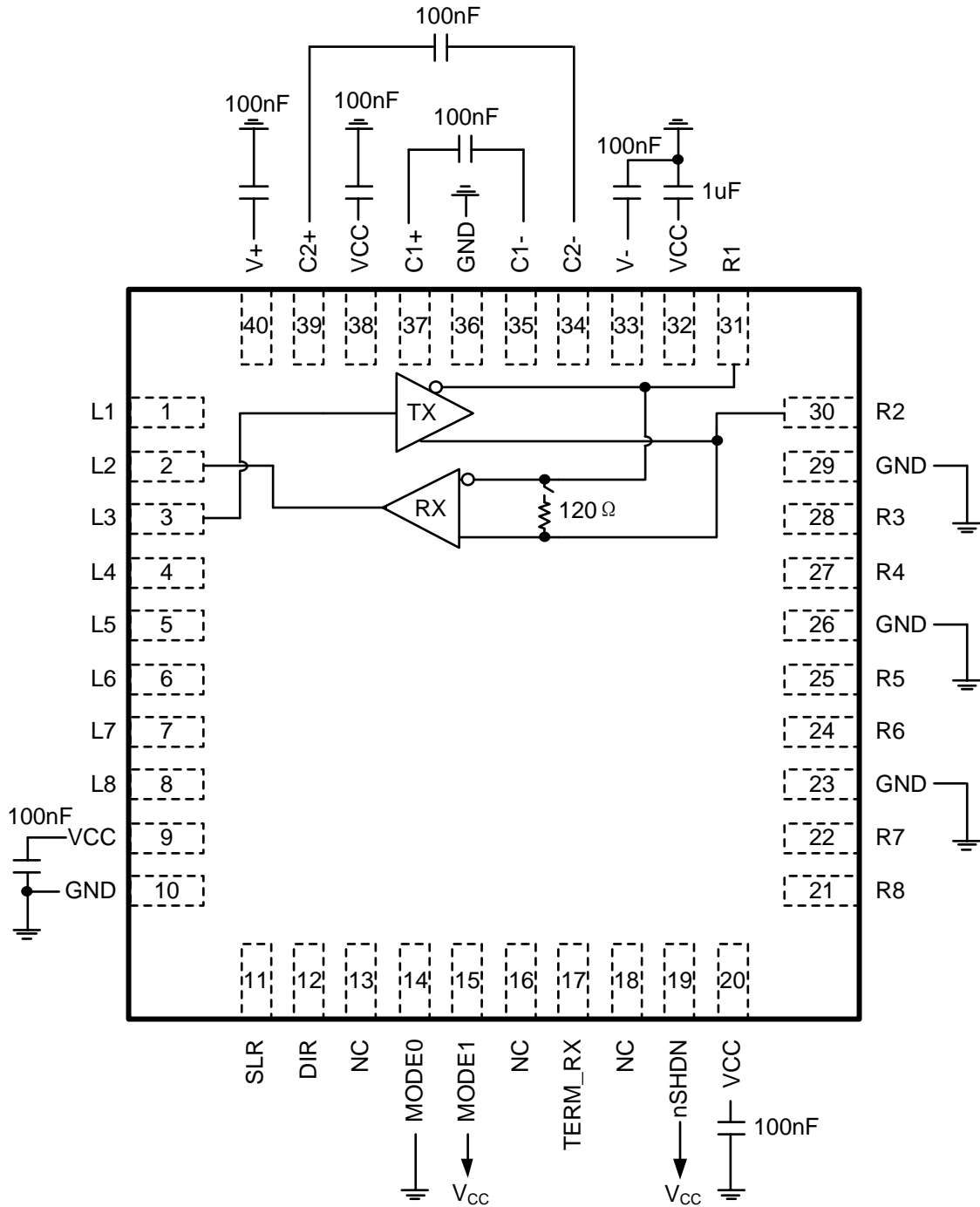


Figure 10-4. UM3035B RS-485 Half duplex Mode

10.3.5 Mode Control

The UM3035B has 2 mode selection pins (MODE1 and MODE0) with 4 different modes. RS-232 3T5R to RS-232 loopback mode transition and RS-232 loopback mode to RS-232 3T5R direct mode transition is not allowed. These 2 mode transitions must go through shutdown mode in between. Rest all combination of mode transitions is allowed. The mode controls for the UM3035B are listed in the table below:

Table 10-1. MODE Control Function Table for UM3035B (Note1)

MODE1	MODE0	Operating mode	Function
L	L	RS-232 loopback, charge pump is ON, V+/V- are regulated	L3 reflects on L2/R2/R3; L4 reflects on L1/R4/R1; L6 reflects on L5, L7, L8, R5, R6, R7 and R8. See Figure 10-2.
L	H	RS-232 3T5R mode, charge pump is ON, V+/V- are regulated	3T5R mode; L3, L4, L6 are Logic inputs for RS232 driver; L1, L2, L5, L7, L8 are Logic outputs. See Figure 10-3.
H	L	RS-485 half duplex mode (charge pump is off)	L2 is RX Logic output; L3 is Driver Logic input; R1, R2 are Bus inverting and non-inverting terminals respectively. See Figure 10-4.
H	H	RS-485 full duplex mode (charge pump is off)	R1, R2 are inverting and non-inverting driver terminals; R3, R4 are non-inverting and inverting receiver terminals. See Figure 10-5.

Note 1: 'H' represents logic high, 'L' represents logic low.

10.3.6 RS-485 Functionality

When the driver enable pin, DIR, is logic high, the differential outputs R2 and R1 follow the logic states at data input L3. A logic high at L3 causes R2 to turn high and R1 to turn low. In this case, the differential output voltage defined as $V_{OD} = V_{R2} - V_{R1}$ is positive. When L3 is low, the output states reverse: R1 turns high, R2 becomes low, and V_{OD} is negative.

When DIR is low, both outputs turn high-impedance. In this condition, the logic state at L3 is irrelevant. The DIR pin has an internal pull-down resistor to ground, thus when left open the driver is disabled (high-impedance) by default. The L3 pin has an internal pull-up resistor to V_{CC} , thus, when left open while the driver is enabled, output R2 turns high and R1 turns low.

Table 10-2 is valid for both RS-485 half duplex and full duplex modes, and is independent of state of TERM_RX and SLR pins.

10.3.6 RS-485 Functionality (continued)

Table 10-2. Driver Function Table

Enable	Input	Outputs		Function
		DIR	L3	
H	H	H	L	Actively drive bus high
H	L	L	H	Actively drive bus low
H	Open	H	L	Actively drive bus high by default
L	X	High impedance	High impedance	Driver disabled
Open	X	High impedance	High impedance	Driver disabled by default

In RS-485 full duplex mode, if nSHDN is high, receiver is always enabled. In RS-485 half duplex mode, receiver is enabled if DIR = Low/float and disabled if DIR = V_{CC}. When the differential input voltage defined as V_{ID} = V_{R2} – V_{R1} or V_{R3} – V_{R4} is higher than the positive input threshold, V_{TH+}, the receiver output, L2, turns high. When V_{ID} is lower than the negative input threshold, V_{TH-}, the receiver output, L2, turns low. If V_{ID} is between V_{TH+} and V_{TH-}, the output is indeterminate.

Internal biasing of the receiver inputs causes the output to go failsafe-high when the transceiver is disconnected from the bus (open-circuit), the bus lines are shorted to one another (short-circuit), or the bus is not actively driven (idle bus).

In half duplex mode, when DIR is high, the receiver output is high-impedance and the magnitude and polarity of V_{ID} are irrelevant.

Table 10-3 is valid irrespective of state of TERM_RX and SLR pins. Other logic outputs L1, L5, L7 and L8 remain high in RS-485 mode.

Table 10-3. Receiver Function Table

Differential Input	Output	Function
V _{ID}	L2	
V _{TH+} < V _{ID}	H	Receive valid bus high
V _{TH-} < V _{ID} < V _{TH+}	?	Indeterminate bus state
V _{ID} < V _{TH-}	L	Receive valid bus low
X	High impedance for DIR = V _{CC} in Half duplex mode	Receiver disabled in half duplex mode for DIR = V _{CC}
Open-circuit bus, Short-circuit bus, Idle (terminated) bus	H	Fail-safe high output

10.3.7 RS-232 Functionality

In RS-232 mode, only way to disable driver is to go in shutdown mode by pulling nSHDN pin low. A logic high at inputs for driver L3, L4 and L6 causes driver outputs R3, R4 and R6 to be driven low towards negative charge pump output V-. A logic low at inputs for driver L3, L4 and L6 causes driver outputs R3, R4 and R6 to be driven high towards positive charge pump output V+. If logic inputs are left floating due to the pull-up resistors on driver logic inputs, the driver outputs are driven low towards V-. Table 10-4 shows the driver functions.

Table 10-4. Driver Function Table

Enable	Inputs	Outputs	Function
nSHDN	L3, L4, L6	R3, R4, R6	
H	H	L (driven towards V-)	Normal operation with inverting logic
H	L	H (driven towards V+)	Normal operation with inverting logic
H	Open	L (driven towards V-)	Since pull-up on logic input pin, output driven low by default
L	X	High impedance	TX and RX are disabled in shutdown mode

For the RS-232 receiver, if the receiver bus inputs are above rising threshold V_{TH+} , corresponding received logic output goes low. Also, if the receiver bus inputs are below falling threshold V_{TH-} , corresponding received logic output goes high. Table 10-5 shows the receiver functions.

Table 10-5. Receiver Function Table

RS-232 Bus Inputs	Outputs	Function
V_{IRX} (voltage on R1, R2, R5, R7 or R8)	L1, L2, L5, L7, L8	
$V_{TH+} < V_{IRX}$	L	Normal operation with inverting logic
$V_{TH-} < V_{IRX} < V_{TH+}$?	Indeterminate bus state
$V_{IRX} < V_{TH-}$	H	Since pull-up on logic input pin, output driven low by default
X	High impedance for nSHDN = GND	Receiver disabled in shutdown mode
Open-circuit bus	H	Fail-safe high output

10.4 Feature Description

10.4.1 Device Protection Features

The UM3035B's bus pins are protected against any DC supply shorts in the range of -16 V to +16 V. In the RS-485 mode, the short circuit current is limited to ± 250 mA to comply with the TIA/EIA-485A standard. In RS-232 mode, current limiting of ± 60 mA is applicable for scenarios where bus pins can short to ground.

The UM3035B also features thermal shutdown protection that disables the driver and the receiver if the junction temperature exceeds the T_{SD} threshold due to excessive power dissipation on-chip.

Supply undervoltage protection is present on V_{CC} supply pin. This maintains the bus output and receiver logic output in known driven state when both the supplies are above their rising undervoltage thresholds. Table 10-6 describes the device behavior in various scenarios of supply levels.

Table 10-6. Supply Function Table

V_{CC}	Driver Output	Receiver Output
$> V_{UVD(RIS)VCC}$	For RS-485 mode, determined by DIR and L3 inputs. For RS-232 mode, determined by L3, L4, L6 inputs. For shutdown mode, Hi-Z	For RS-485 mode, determined by DIR and (R1-R2) or (R3- R4) inputs. For RS-232 mode, determined by R1, R2, R5, R7, R8 inputs. For shutdown mode, Hi-Z
$< V_{UVD(RIS)VCC}$	High impedance	High impedance

10.4.2 RS-485 Receiver Fail-Safe Operation

The RS-485 differential receiver of the UM3035B is failsafe to invalid bus states caused by the following conditions:

- Open bus conditions, such as a disconnected connector
- Shorted bus conditions, such as cable damage shorting the twisted-pair together
- Idle bus conditions that occur when no driver on the bus is actively driving

In any of these cases, the fail-safe operation brings a logic high state on receiver outputs so that avoid the indeterminate output of the receiver.

10.4.3 Integrated Switchable Termination Resistor

The UM3035B has 1 termination resistor of nominal 120 Ω. When in RS-485 half duplex mode, the termination resistor is configured between R1/R2 buses. When in RS-485 full duplex mode, the termination resistor is configured between R3/R4 buses. Both termination resistors are enabled or disabled using pins as described in Table 10-7.

Termination resistor is OFF in RS-232 loopback, RS-232 3T5R, unpowered and thermal shutdown modes.

Table 10-7. Integrated Termination Function for UM3035B

Device mode	TERM_RX configuration	Function	Notes
RS-485 Full duplex mode	TERM_RX = V _{CC}	120 Ω enabled between R3 and R4	Termination between R3/R4 is disabled by default
	TERM_RX = GND or float	120 Ω disabled between R3 and R4	
RS-485 Half duplex mode	TERM_RX = V _{CC}	120 Ω enabled between R1 and R2	Termination between R1/R2 is disabled by default
	TERM_RX = GND or float	120 Ω disabled between R1 and R2	

The termination block offers a resistive load to the bus, and does not alter the magnitude or phase of the bus signals from DC to 20Mbps signaling. The Integrated 120 Ω termination resistor is designed for minimum variation across temperature and across common mode voltage on bus pins.

10.4.4 Switchable Operating Data Rates

The UM3035B can be used in slow speed or fast speed RS-485 and RS-232 applications by configuring Slew rate control (SLR) pin and. Table 10-8 describes slew rate control function for the UM3035B.

Table 10-8. Slew Rate Control Function for UM3035B

SLR configuration	Maximum speed of Driver	Maximum speed of Receiver	Notes
SLR = V _{CC}	RS-485 mode: 250kbps RS-232 mode: 250kbps	RS-485 mode: 250kbps RS-232 mode: 250kbps	Active high slew rate limiting applied on driver output. In this configuration, glitch filter in receiver path for RS-485 is enabled
SLR = GND or float	RS-485 mode: 20Mbps RS-232 mode: 1Mbps	RS-485 mode: 20Mbps RS-232 mode: 1Mbps	Slew rate limiting on driver output disabled.

For RS-485 half and full duplex modes, receiver path in the slow speed mode provides additional noise filtering. To attenuate high frequency noise pulses from the bus which can be wrongly interpreted as valid data.

10.4.5 Diagnostic Loopback

The UM3035B provides complete path diagnostic loopback modes for RS-232. The Diagnostic mode internally shorts bus outputs to bus inputs. So, if data is toggled from logic input, data reaches bus and is reflected back on logic buffer output. This enables MCU to detect bus side short (due to connector/cable) by comparing logic input and logic output.

In RS-232 loopback mode, L3 reflects on L2/R2/R3; L4 reflects on L1/R4/R1; L6 reflects on L5, L7, L8, R5, R6, R7 and R8 enabling to detect short to ground on all bus pins from R1 through R8. RS-232 loopback mode is optimized for -40°C to 125°C ambient temperature. RS-232 diagnostic loopback can be performed on a node (DUT1) even with another node (DUT2) connected via cable, but listening node (DUT2) is not allowed to transmit anything on the RS232 lines while loopback check by DUT1 is ongoing.

10.4.6 Integrated Charge pump for RS-232

The UM3035B has integrated high-efficiency and low-noise charge pump to generate large output voltages for RS-232 signals. Charge pump consists of a voltage doubler and an inverter to regulate the voltage to nominal $\pm 5.5V$ or to $\pm 8.5V$ for 3.3V or 5V V_{CC} operation respectively. Charge pump needs four external ceramic capacitors (2 flying capacitors and 2 storage capacitors) and allows for single supply operation for RS-232.

11 Application and Implementation

11.1 Application Information

The UM3035B is highly integrated multiprotocol transceivers supporting RS-232, RS-422 and RS-485 physical layer and is used for asynchronous data transmissions. Two MODE pins allow for the configuration of different operating modes. The device allows point-to-point RS-232 communication port and multipoint RS-485 communication port over common connector. The device also features integrated 120Ω switchable termination resistor on RS-485 bus lines which enables same device to be used for middle nodes or end nodes in an RS-485 network. When the device is configured in RS-232 mode, RS-485 circuits and 120Ω termination are disabled and do not interfere in RS-232 communication. For RS-232 communication, charge pump and $5k\Omega$ resistor to ground on receiver bus pins is integrated in the device. This $5k\Omega$ resistor and charge pump is automatically disabled in RS-485 mode. Slew rate limiting pin is provided so that same device can be used in slow speed or fast speed RS-485 and RS-232 applications. All these features make the devices completely flexible and suitable for various application needs. Integration of termination resistor saves significant PCB area compared to discrete implementation.

11.1 Typical Application

The UM3035B consists of 3 drivers and 5 receivers and dual charge pump circuit to enable RS-232 point-to-point serial communication. The device provides the electrical interface between an asynchronous communication controller and the serial-port connector.

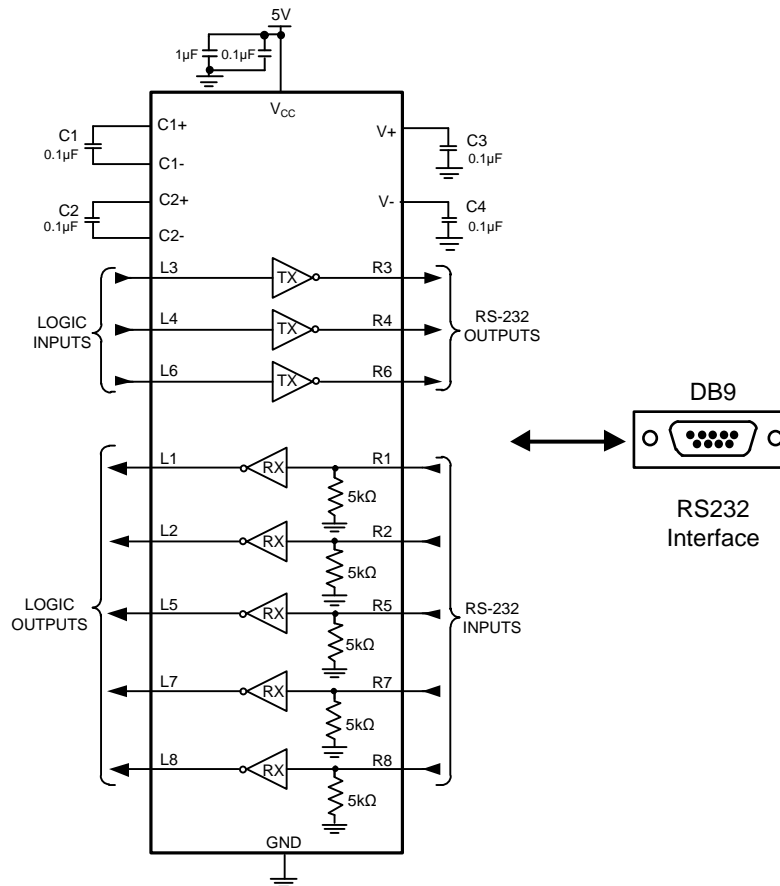


Figure 11-1. RS-232 serial communication

11.1 Typical Application (continued)

An RS-485 bus consists of multiple transceivers connecting in parallel to a bus cable. To eliminate line reflections, each cable end is terminated with a termination resistor, R_T , whose value matches the characteristic impedance, Z_0 , of the cable. This method, known as parallel termination, generally allows for higher data rates over longer cable length.

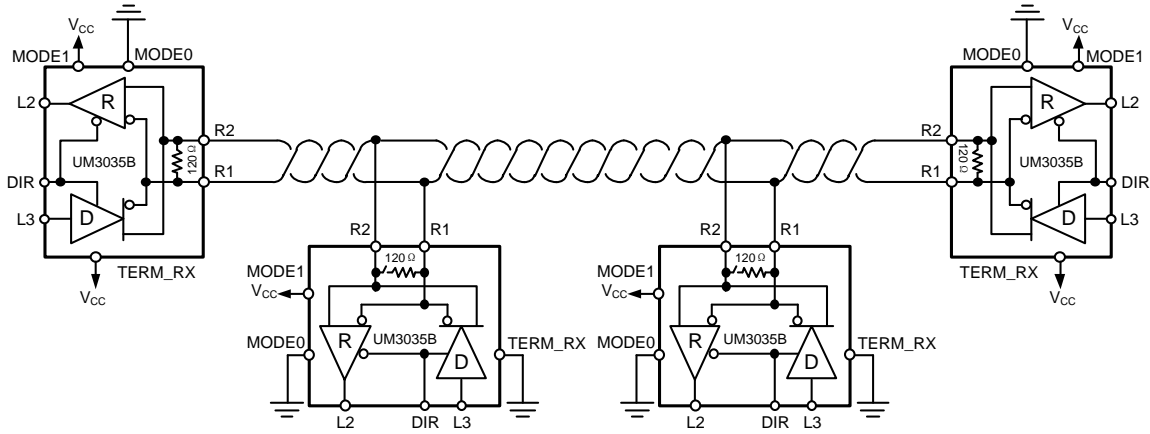


Figure 11-2. Typical RS-485 Network with Half-Duplex Transceivers

The UM3035B can support RS-232, RS-485, and RS-422 protocols over a shared DB9 interface. This significantly reduces the number of required interfaces and simplifies wiring complexity.

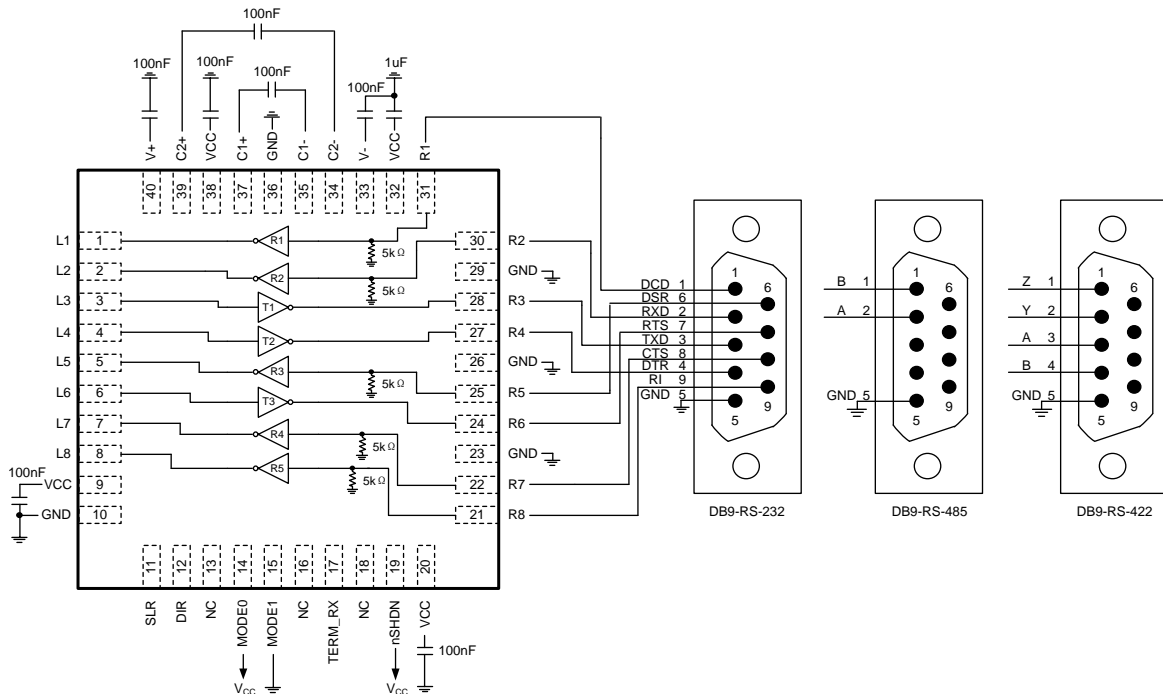
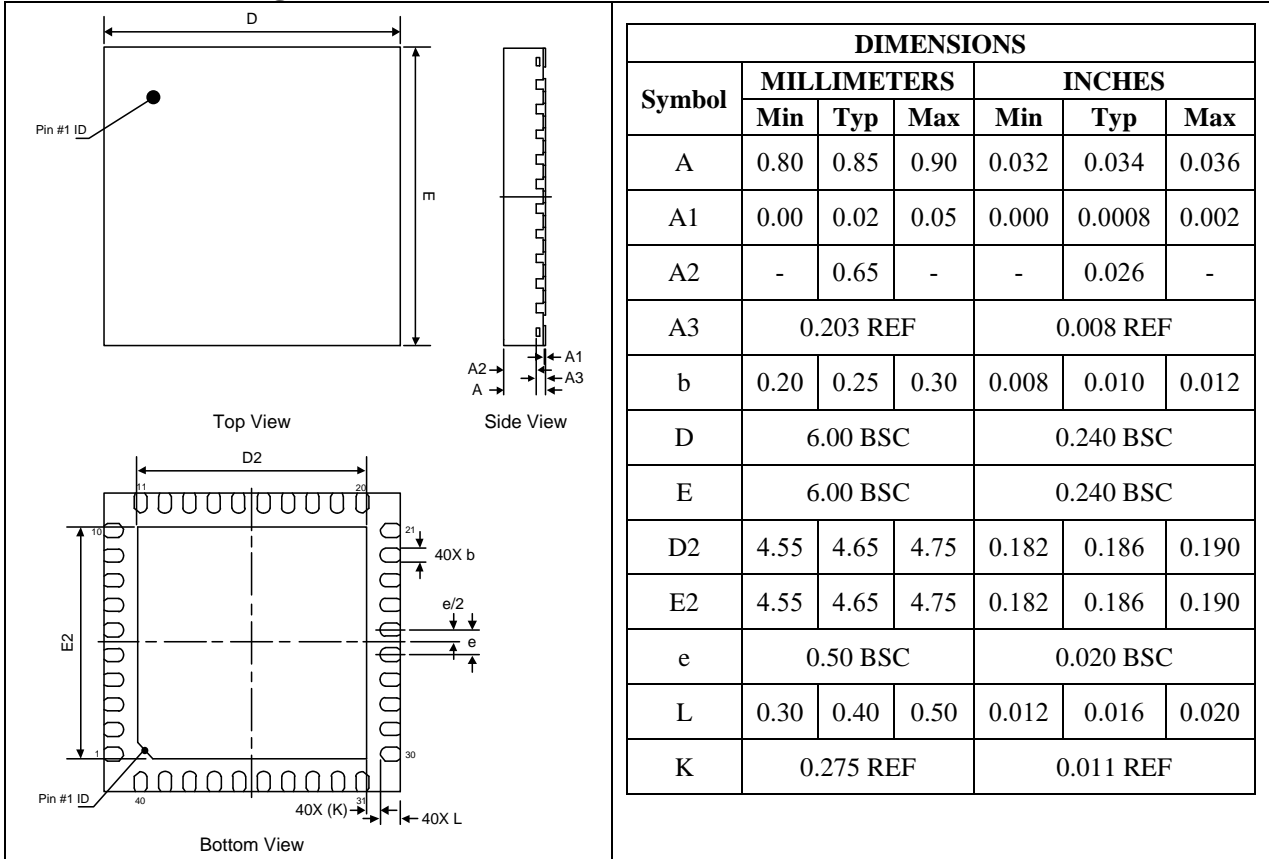


Figure 11-3. UM3035B Application on a shared DB9 connector

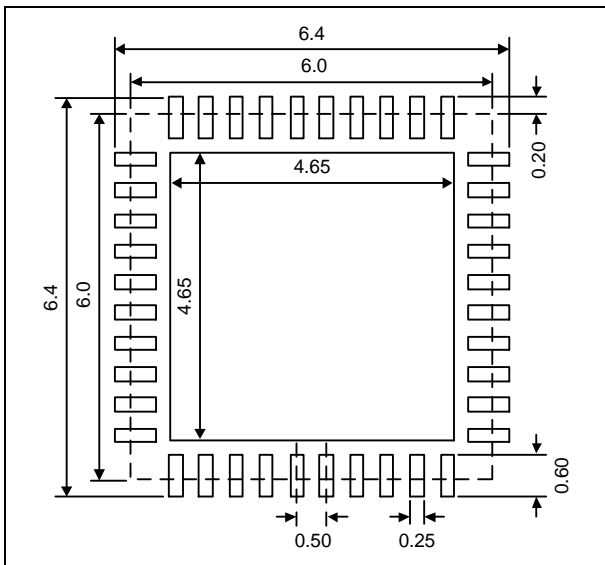
Package Information

QFN40 6.0×6.0

Outline Drawing



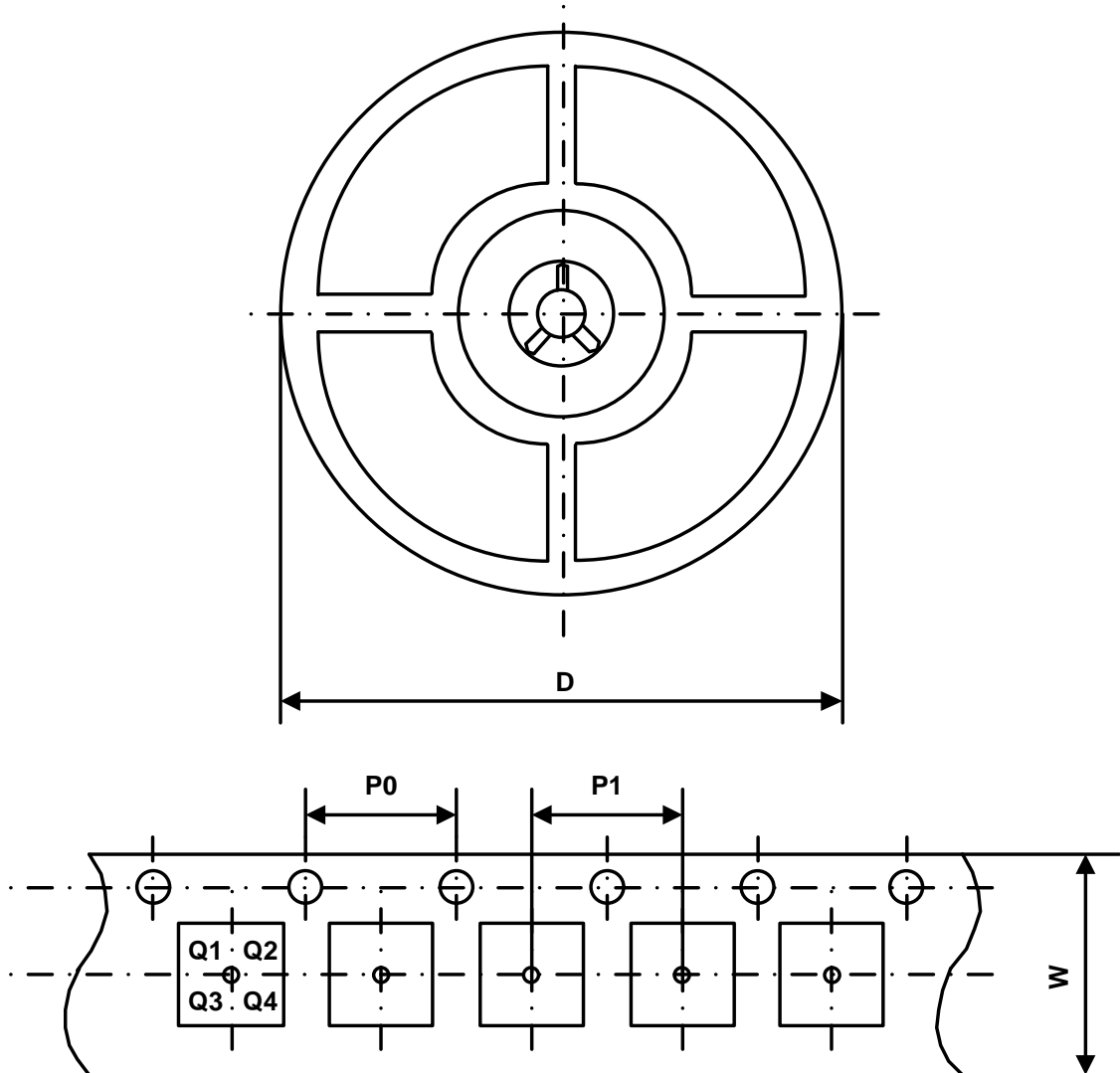
Land Pattern



NOTES:

1. Compound dimension: 6.00×6.00;
2. Unit: mm;
3. General tolerance ±0.05mm unless otherwise specified;
4. The layout is just for reference.

Packing Information



Part Number	Package Type	Carrier Width (W)	Pitch (P0)	Pitch (P1)	Reel Size (D)	PIN 1 Quadrant
UM3035BQA AE	QFN40 6.0×6.0	16 mm	4 mm	8 mm	330 mm	Q1

GREEN COMPLIANCE

Union Semiconductor is committed to environmental excellence in all aspects of its operations including meeting or exceeding regulatory requirements with respect to the use of hazardous substances. Numerous successful programs have been implemented to reduce the use of hazardous substances and/or emissions.

All Union components are compliant with the RoHS directive, which helps to support customers in their compliance with environmental directives. For more green compliance information, please visit:

<https://www.union-ic.com/Quality.html>

IMPORTANT NOTICE

The information in this document has been carefully reviewed and is believed to be accurate. Nonetheless, this document is subject to change without notice. Union assumes no responsibility for any inaccuracies that may be contained in this document, and makes no commitment to update or to keep current the contained information, or to notify a person or organization of any update. Union reserves the right to make changes, at any time, in order to improve reliability, function or design and to attempt to supply the best product possible.