

3V to 5.5V, 50Mbps, Fail-Safe, RS-485 Transceivers

UM13085 SOP8/MSOP8/DFN8 3.0×3.0

1 Description

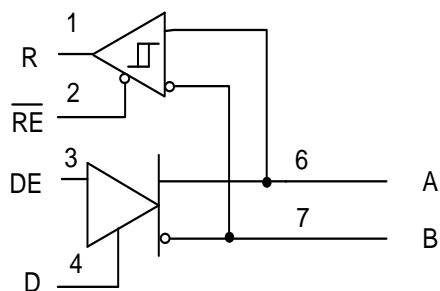
The UM13085 is $\pm 18\text{V}$ fault-protected, half-duplex, RS-485 transceiver operating on a single 3V to 5.5V supply voltage. Bus interface pins are protected against overvoltage conditions during all modes of operation ensuring robust communication in rugged industrial environments.

The UM13085 is available in 50Mbps. Extended $\pm 15\text{V}$ input common-mode range ensures reliable data communication over longer cable run lengths and/or in the presence of large ground loop voltages. Enhanced 250mV receiver hysteresis ensures high noise rejection. In addition, the receiver fail-safe feature guarantees a logic high when the inputs are open or shorted together.

The UM13085 is available in SOP8, MSOP8 and DFN8 3.0×3.0 packages for space-constrained applications. The device is characterized over ambient free-air temperatures from -40°C to 125°C .

2 Applications

- Automotive data links
- Industrial-Control Local Area Networks
- Integrated Services Digital Networks
- Building automation
- Grid infrastructure
- Electricity meters
- Process analytics
- Video surveillance



UM13085 Simplified Schematic

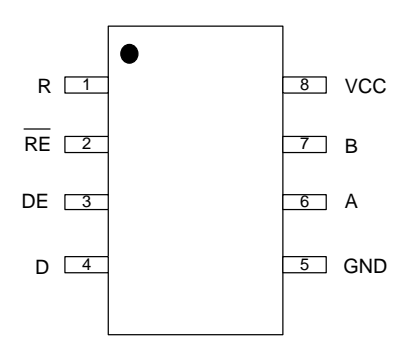
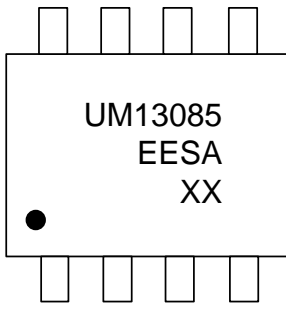
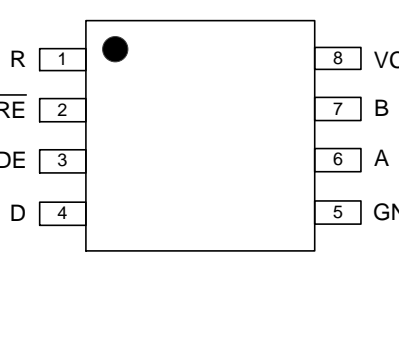
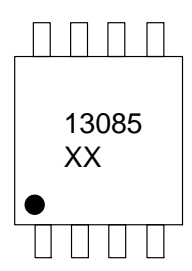
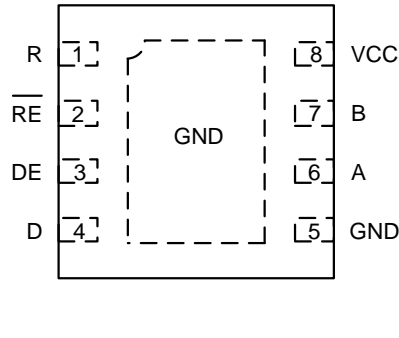
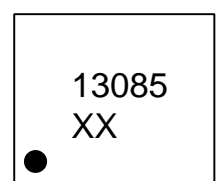
3 Features

- Meets or exceeds the requirements of the TIA/EIA-485A standards
- 3V to 5.5V supply voltage
- Differential output exceeds 2.1 V for PROFIBUS compatibility with 5V supply
- Bus I/O protection
 - $\pm 18\text{V}$ DC bus fault
 - $\pm 8\text{kV}$ Human body model (HBM)
- Latch-up performance exceeds 200mA per JESD 78
- Half-duplex device available in 50 Mbps
- Extended ambient temperature range: -40°C to 125°C
- Extended operational common-mode range: $\pm 15\text{V}$
- Open, short, and idle bus failsafe
- Thermal shutdown
- 1/8 unit load (up to 256 bus nodes)
- Small SOP8, MSOP8 and DFN8 3.0×3.0 packages

4 Ordering Information

Part Number	Mark Code	Package Type	Shipping Qty
UM13085EESA	UM13085EESA	SOP8	3000pcs/13Inch Tape & Reel
UM13085EEM8	13085	MSOP8	4000pcs/13Inch Tape & Reel
UM13085EEDA	13085	DFN8 3.0×3.0	3000pcs/13Inch Tape & Reel

5 Pin Configuration and Function

	 <p>XX: Week Code UM13085EESA SOP8</p>
	 <p>XX: Week Code UM13085EEM8 MSOP8</p>
	 <p>XX: Week Code UM13085EEDA DFN8 3.0×3.0</p>

5 Pin Configuration and Function (continued)

Table 5-1. Pin Functions

Pin No.	Pin Name	Function
1	R	Receive data output
2	\overline{RE}	Receiver enable, active low; integrated pull-up
3	DE	Driver enable, active high; integrated pull-down
4	D	Driver data input; integrated pull-up
5	GND	Local device ground
6	A	Driver output or receiver input (complementary to B)
7	B	Driver output or receiver input (complementary to A)
8	VCC	Supply voltage

6 Specifications

6.1 Absolute Maximum Ratings (Note 1)

Symbol	Parameter	Conditions	Min	Typ	Max	Unit
V _{CC}	Supply voltage		-0.5		6.5	V
V _I	Voltage on A, B pins		-18		18	V
	Voltage on any logic pins (D, DE, \overline{RE})		-0.3		5.7	V
V _{ESD}	Human body model (HBM), per ANSI/ESDA/JEDEC JS-001	Bus terminals and GND		±8		kV
		All pins except bus terminals and GND		±2		kV
I _O	RXD output current		-24		24	mA
T _{STG}	Storage temperature		-65		150	°C
T _L	Lead Temperature for Soldering 10 Seconds				260	°C

Note 1: Operation outside the Absolute Maximum Ratings may cause permanent device damage. Absolute maximum ratings do not imply functional operation of the device at these or any other conditions beyond those listed under Recommended Operating Conditions. If briefly operating outside the Recommended Operating Conditions but within the Absolute Maximum Ratings, the device may not sustain damage, but it may not be fully functional. Operating the device in this manner may affect device reliability, functionality, performance, and shorten the device lifetime.

6.2 Recommended Operating Conditions

Symbol	Parameter	Conditions	Min	Typ	Max	Unit
V _{CC}	Supply Voltage		3		5.5	V
V _I	Input voltage at any bus terminal (separately or common mode)	Note 1	-15		15	V
V _{ID}	Differential input voltage		-15		15	V
I _O	Output current, driver		-60		60	mA
I _{OR}	Output current, receiver		-8		8	mA
R _L	Differential load resistance		54	60		Ω
1/ t _{UI}	Signaling rate				50	Mbps
T _A	Operating free-air temperature		-40		125	°C
T _J	Junction temperature		-40		150	°C

Note 1: The algebraic convention, in which the least positive (most negative) limit is designated as minimum is used in this data sheet.

6.3 Electrical Characteristics (Static)

$V_{CC} = 3V$ to $5.5V$, $V_{IO} = 1.65V$ to $5.5V$, $T_A = -40\text{ }^\circ\text{C}$ to $125\text{ }^\circ\text{C}$, unless otherwise noted. All typical values are at $25\text{ }^\circ\text{C}$ and supply voltage of $V_{CC} = 5V$, $V_{IO} = 3.3V$.

Symbol	Parameter	Conditions	Min	Typ	Max	Unit
Supply						
I_{CC}	Supply current	$\overline{RE} = 0V$, $DE = V_{CC}$, No load (Driver and receiver enabled)		2	5	mA
		$\overline{RE} = V_{CC}$, $DE = V_{CC}$, No load (Driver enabled, receiver disabled)		2	5	mA
		$\overline{RE} = 0V$, $DE = 0V$, No load (Driver disabled, receiver enabled)		1.2	3	mA
		$\overline{RE} = V_{CC}$, $DE = 0V$, D = open, No load (Driver and receiver disabled)		1.5	10	μA
Driver						
$ V_{OD} $	Driver differential output voltage magnitude	$R_L = 60\ \Omega$, $-15V \leq V_{TEST} \leq 15V$, See Figure 7-1	1.5	3.1		V
		$R_L = 60\ \Omega$, $-15V \leq V_{TEST} \leq 15V$, $4.5V \leq V_{CC} \leq 5.5V$, See Figure 7-1	2.1	3.1		V
		$R_L = 100\ \Omega$, See Figure 7-2	2	4		V
		$R_L = 54\ \Omega$, See Figure 7-2	1.5	3.3		V
$\Delta V_{OD} $	Change in magnitude of driver differential output voltage	$R_L = 54\ \Omega$ or $100\ \Omega$ See Figure 7-2	-200		200	mV
V_{OC}	Common-mode output voltage	$R_L = 54\ \Omega$ or $100\ \Omega$ See Figure 7-2	1	$V_{CC}/2$	3	V
$\Delta V_{OC(SS)}$	Steady-state common-mode output voltage	$R_L = 54\ \Omega$ or $100\ \Omega$ See Figure 7-2	-200		200	mV
I_{OS}	Short-circuit output current	$DE = V_{CC}$, $-18V \leq (V_A$ or $V_B) \leq 18V$	-250		250	mA

6.3 Electrical Characteristics (Static)---continued (Note 1)

$V_{CC} = 3V$ to $5.5V$, $V_{IO} = 1.65V$ to $5.5V$, $T_A = -40\text{ }^{\circ}\text{C}$ to $125\text{ }^{\circ}\text{C}$, unless otherwise noted. All typical values are at $25\text{ }^{\circ}\text{C}$ and supply voltage of $V_{CC} = 5V$, $V_{IO} = 3.3V$.

Symbol	Parameter	Conditions	Min	Typ	Max	Unit
Receiver						
I_I	Bus input current	$DE = 0V$, $V_{CC} = 0V$ or $5.5V$, $V_I = 12V$			125	μA
		$DE = 0V$, $V_{CC} = 0V$ or $5.5V$, $V_I = -7V$	-100			
V_{TH+}	Positive-going input threshold voltage	Over common-mode range of $\pm 15V$		125	200	mV
V_{TH-}	Negative-going input threshold voltage		-200	-125		
V_{HYS}	Input hysteresis			250		
$C_{A,B}$	Input differential capacitance	Measured between A and B, $f = 1\text{ MHz}$		50		pF
V_{OH}	Output high voltage	$I_{OH} = -8\text{ mA}$	$V_{CC} - 0.4$	$V_{CC} - 0.2$		V
V_{OL}	Output low voltage	$I_{OL} = 8\text{ mA}$		0.2	0.4	V
I_{OZ}	Output high-impedance current	$V_O = 0V$ or V_{CC} , $\overline{RE} = V_{CC}$	-1		1	μA
Logic						
V_{IH}	Input High Voltage	DE, D, \overline{RE}	$0.7 * V_{CC}$			V
V_{IL}	Input low Voltage	DE, D, \overline{RE}			$0.3 * V_{CC}$	V
I_I	Input current on DE pin	$3V \leq V_{CC} \leq 5.5V$, $0V \leq V_{IN} \leq V_{CC}V$			25	μA
	Input current on D, \overline{RE} pin	$3V \leq V_{CC} \leq 5.5V$, $0V \leq V_{IN} \leq V_{CC}V$	-10			μA
Thermal Protection						
T_{SD}	Thermal shutdown threshold	Temperature rising		150		$^{\circ}\text{C}$
T_{HYS}	Thermal shutdown hysteresis			10		$^{\circ}\text{C}$

6.4 Electrical Characteristics (Dynamic) (Note 1)

$V_{CC} = 3V$ to $5.5V$, $V_{IO} = 1.65V$ to $5.5V$, $T_A = -40\text{ }^{\circ}\text{C}$ to $125\text{ }^{\circ}\text{C}$, unless otherwise noted. All typical values are at $25\text{ }^{\circ}\text{C}$ and supply voltage of $V_{CC} = 5V$, $V_{IO} = 3.3V$.

Symbol	Parameter	Conditions	Min	Typ	Max	Unit
Driver						
t_R, t_F	Driver differential output rise/fall time	$R_L = 54\ \Omega$, $C_L = 50\ \text{pF}$, see Figure 7-3		3	6	ns
t_{PHL}, t_{PLH}	Driver propagation delay time			6.5	20	ns
$t_{SK(P)}$	Driver differential output pulse skew, $ t_{PHL} - t_{PLH} $				3	ns
t_{PHZ}, t_{PLZ}	Disable time	See Figure 7-4 and Figure 7-5			200	ns
t_{PZH}, t_{PZL}	Enable time	$\overline{RE} = 0V$, See Figure 7-4 and Figure 7-5			100	ns
t_{PSH}, t_{PSL}		$\overline{RE} = V_{CC}$, See Figure 7-4 and Figure 7-5		2.4	5	μs
t_{SD}	Time to shutdown	$\overline{RE} = V_{CC}$, See Figure 7-4 and Figure 7-5	50		500	ns
Receiver						
t_R, t_F	Receiver output rise/fall time	$C_L = 15\ \text{pF}$, see Figure 7-6		4.5	6	ns
t_{PHL}, t_{PLH}	Receiver propagation delay time		9	13	40	ns
$t_{SK(P)}$	Receiver output pulse skew, $ t_{PHL} - t_{PLH} $				3	ns
t_{PHZ}, t_{PLZ}	Receiver disable time			14	40	ns
t_{PZL}, t_{PZH}	Receiver enable time	$DE = V_{CC}$, see Figure 7-7		17	40	ns
t_{PSH}, t_{PSL}		$DE = 0V$, see Figure 7-8		2.8	4	μs
t_{SD}	Time to shutdown	$DE = 0V$, see Figure 7-8	50		500	ns

7 Parameter Measurement Information

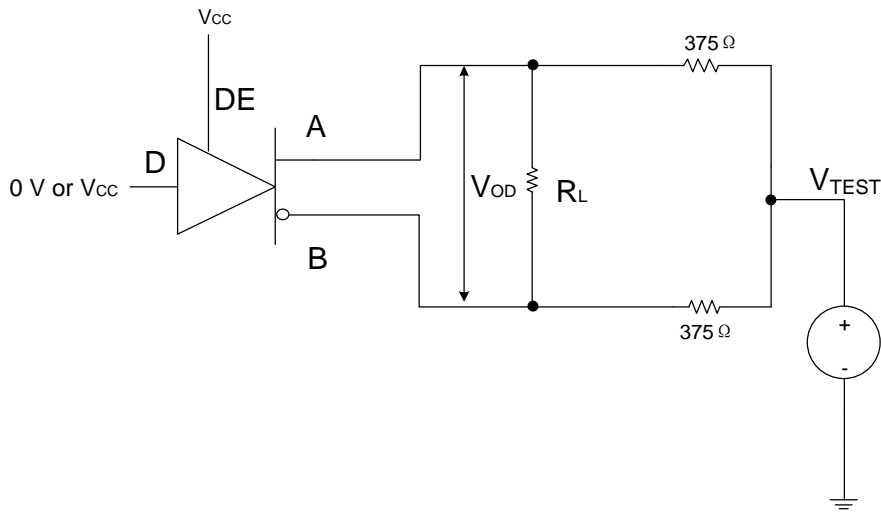


Figure 7-1. Measurement of Driver Differential Output Voltage With Common-Mode Load

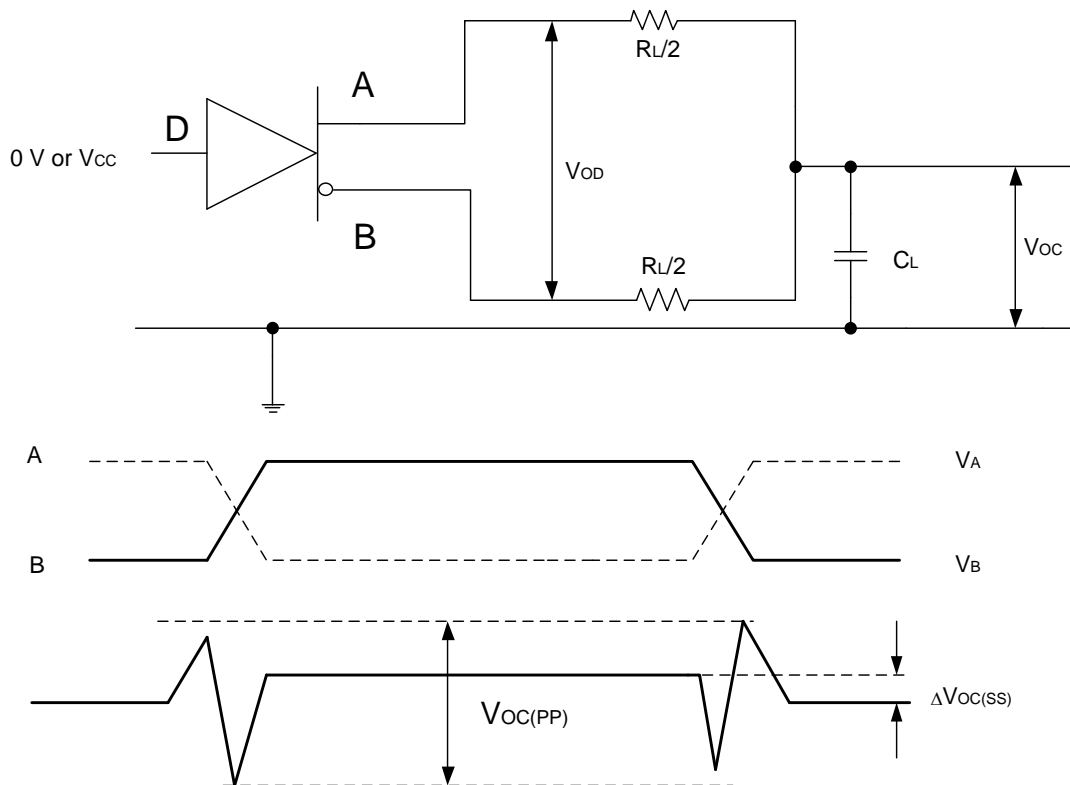


Figure 7-2. Measurement of Driver Differential and Common-Mode Output With RS-485 Load

7 Parameter Measurement Information (continued)

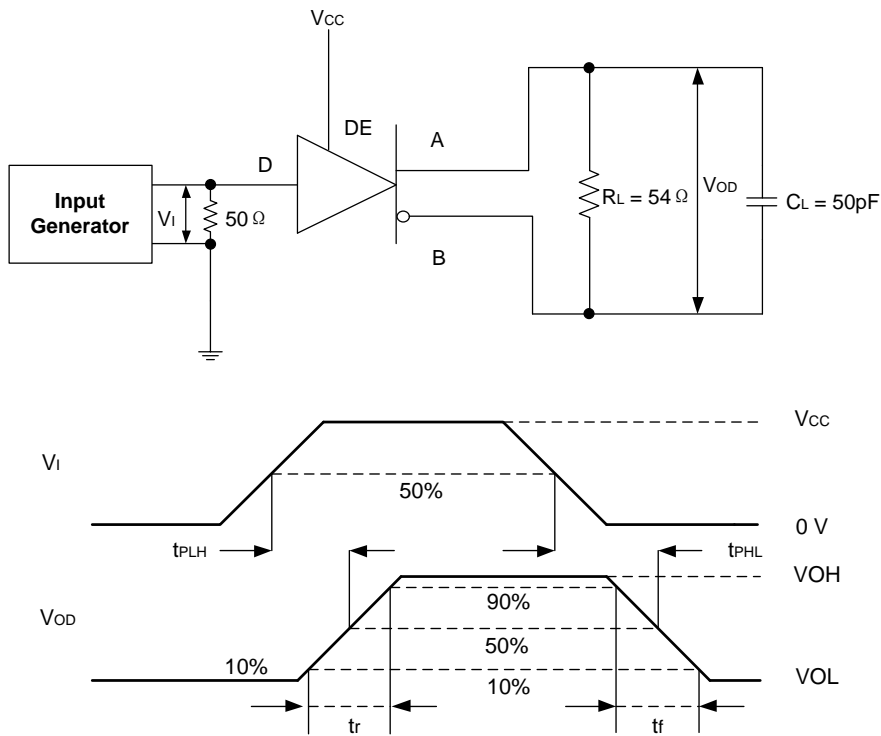


Figure 7-3. Measurement of Driver Differential Output Rise and Fall Times and Propagation Delays

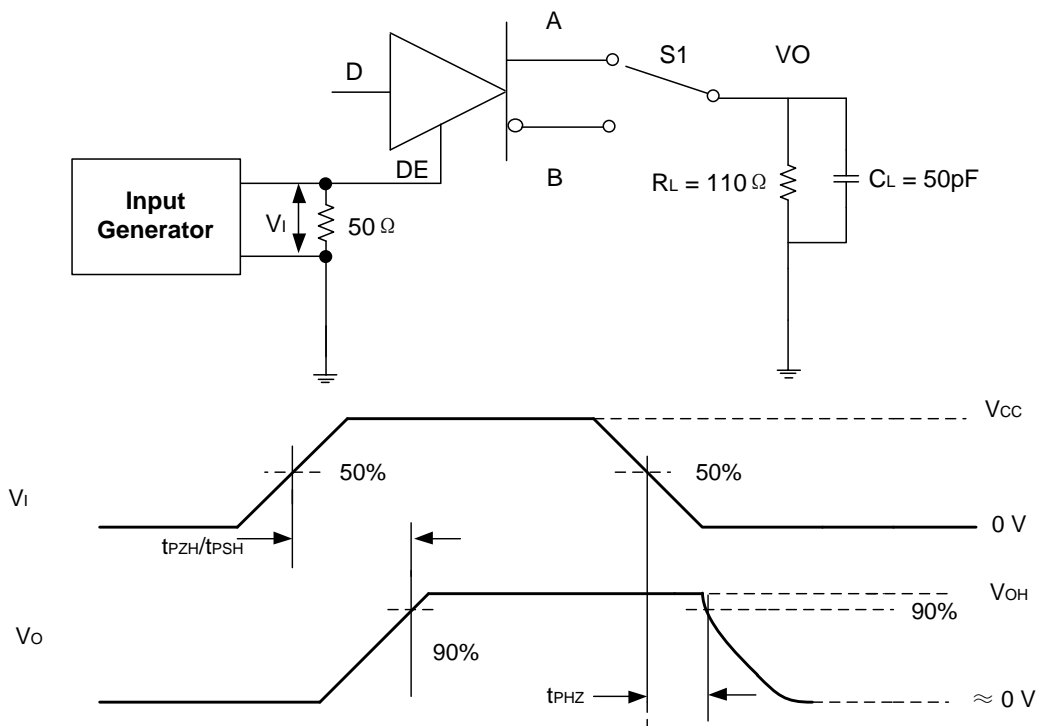


Figure 7-4. Measurement of Driver Enable and Disable Times With Active High Output and Pull-Down Load

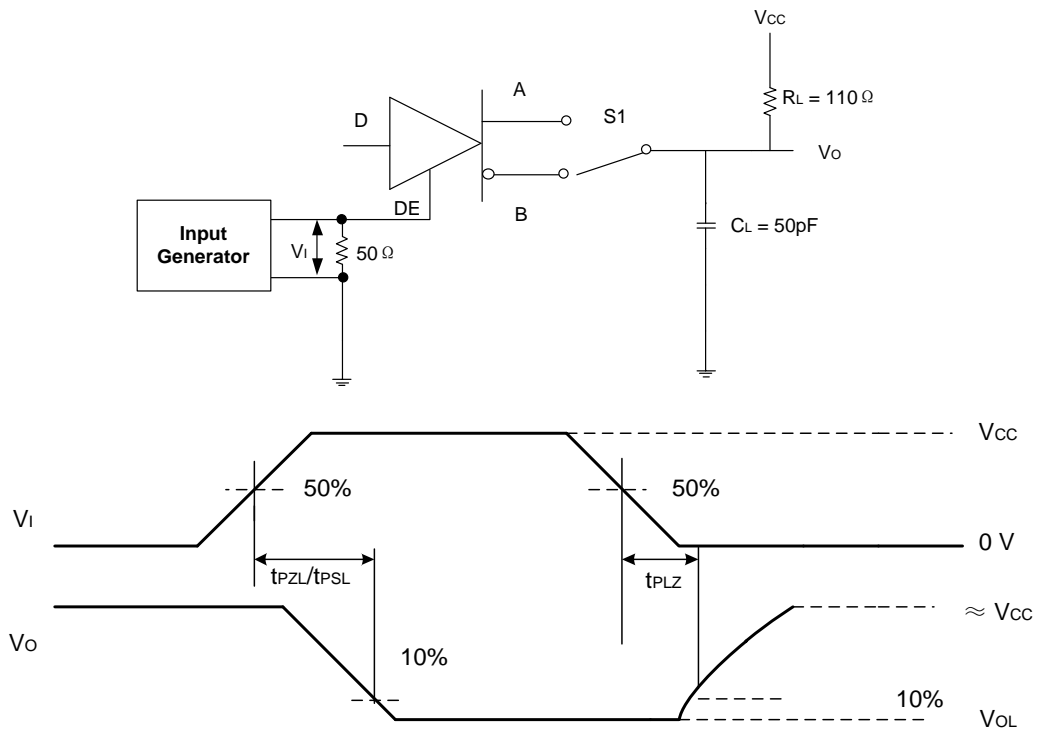
7 Parameter Measurement Information (continued)


Figure 7-5. Measurement of Driver Enable and Disable Times With Active Low Output and Pull-up Load

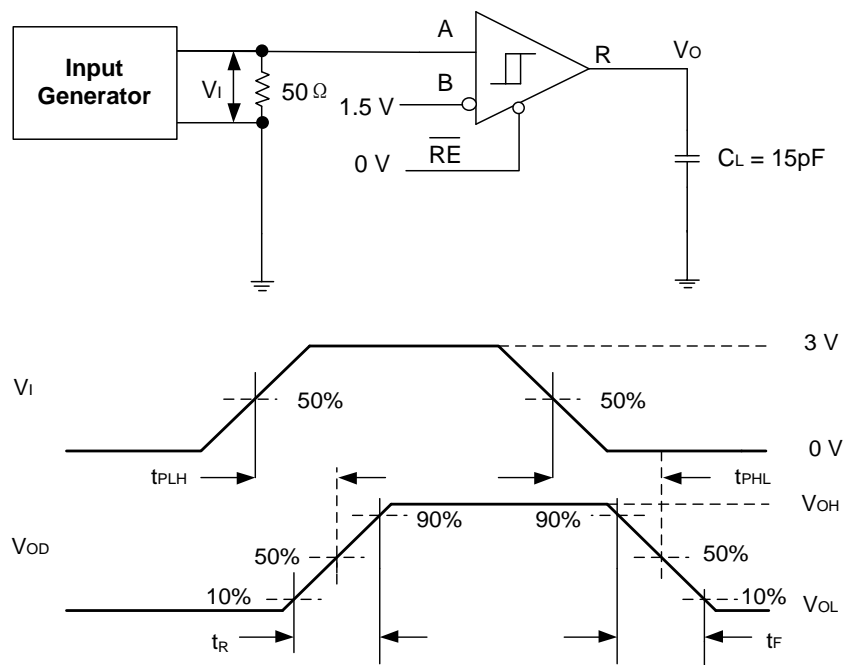


Figure 7-6. Measurement of Receiver Output Rise and Fall Times and Propagation Delays

7 Parameter Measurement Information (continued)

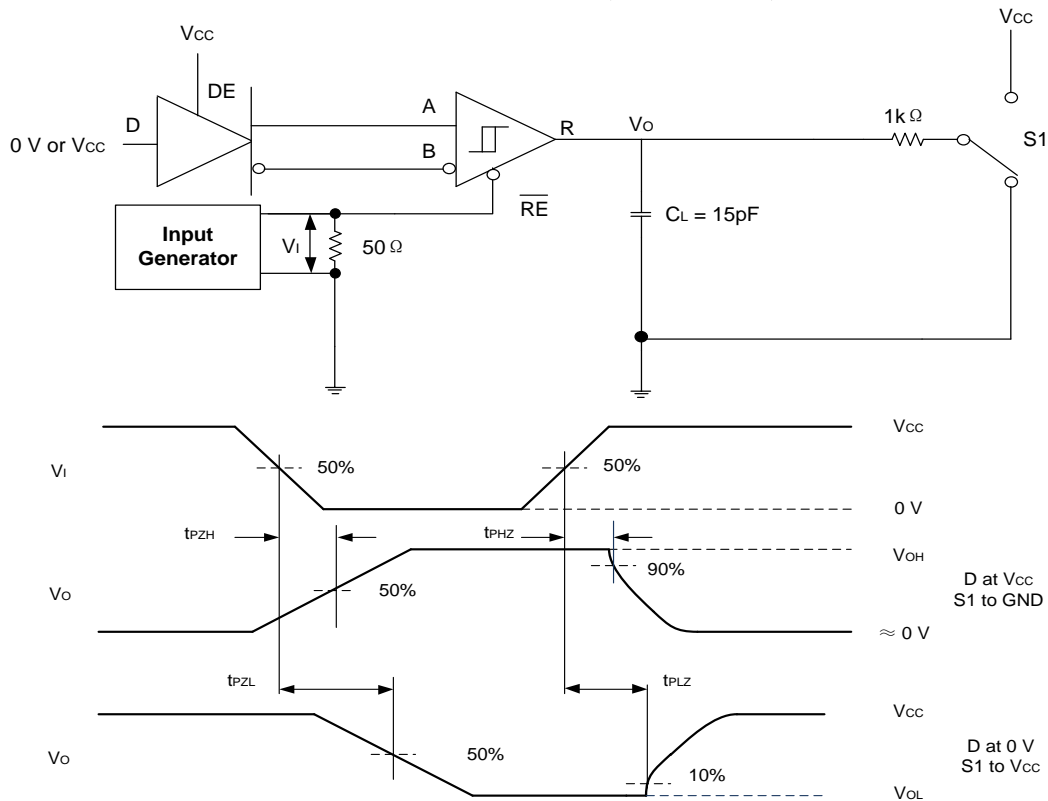


Figure 7-7. Measurement of Receiver Enable/Disable Times With Driver Enabled

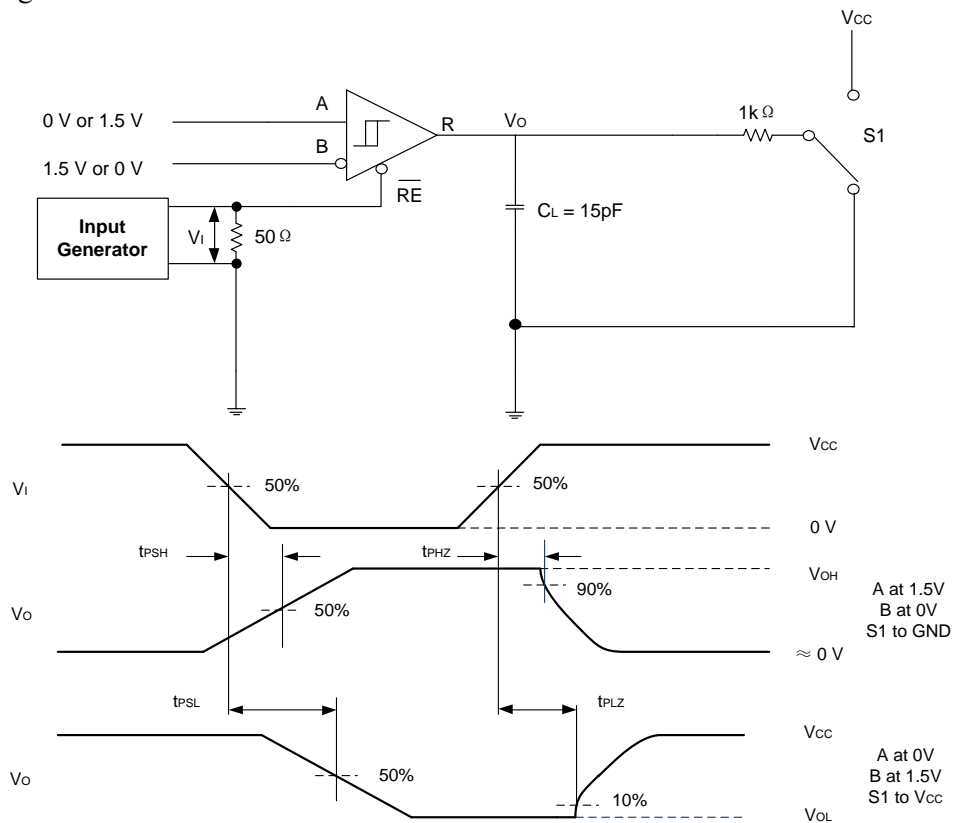


Figure 7-8. Measurement of Receiver Enable Times With Driver Disabled

8 Detailed Description

8.1 Overview

The UM13085 is fault-protected, half duplex RS-485 transceivers available in speed grade suitable for data transmission up to 50 Mbps. The device has active-high driver enables and active-low receiver enables. A shutdown current of less than 10 μA can be achieved by disabling both driver and receiver.

8.2 Functional Block Diagram

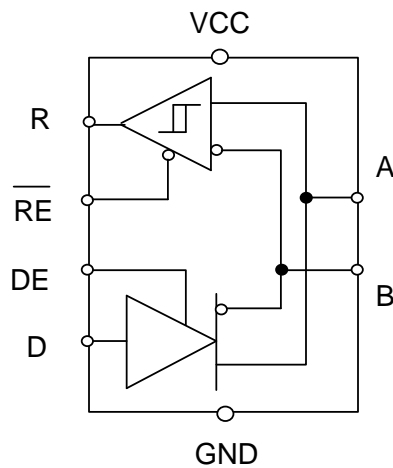


Figure 8-1. UM13085 Block Diagram

9 Feature Description

9.1 $\pm 18V$ Fault Protection

The UM13085 has extended bus fault protection compared to standard RS-485 devices. Transceivers that operate in rugged industrial environments are often exposed to voltage transients greater than the -7 V to +12 V defined by the TIA/EIA-485A standard. To protect against such conditions, the generic RS-485 devices with lower absolute maximum ratings requires expensive external protection components. To simplify system design and reduce overall system cost, the UM13085 is protected up to $\pm 18V$ without the need for any external components.

9.2 Receiver Fail-Safe Operation

The receivers are fail-safe to invalid bus states caused by the following:

- Open bus conditions, such as a disconnected connector
- Shorted bus conditions, such as cable damage shorting the twisted-pair together
- Idle bus conditions that occur when no driver on the bus is actively driving

In any of these cases, the differential receiver outputs a failsafe logic high state so that the output of the receiver is not indeterminate.

9.3 Low-Power Shutdown Mode

Driving DE low and \overline{RE} high for longer than 500 ns puts the devices into the shutdown mode. If either DE goes high or \overline{RE} goes low, the counters reset. The device does not enter the shutdown mode if the enable pins are in disable state for less than 50 ns. This feature prevents the devices from accidentally going into shutdown mode due to skew between DE and \overline{RE} .

9.4 Device Functional Modes

When the driver enable pin, DE, is logic high, the differential outputs A and B follow the logic states at data input D. A logic high at D causes A to turn high and B to turn low. In this case, the differential output voltage defined as $V_{OD} = V_A - V_B$ is positive. When D is low, the output states reverse: B turns high, A becomes low, and V_{OD} is negative.

When DE is low, both outputs turn high-impedance. In this condition, the logic state at D is irrelevant. The DE pin has an internal pull-down resistor to ground, thus when left open the driver is disabled (high-impedance) by default. The D pin has an internal pull-up resistor to V_{CC} , thus, when left open while the driver is enabled, output A turns high and B turns low.

9.4 Device Functional Modes (continued)

Table 9-1. Driver Function Table

INPUT	ENABLE	OUTPUTS		FUNCTION
		A	B	
D	DE	A	B	
H	H	H	L	Actively drive bus high
L	H	L	H	Actively drive bus low
X	L	Z	Z	Driver disabled
X	OPEN	Z	Z	Driver disabled by default
OPEN	H	H	L	Actively drive bus high by default

When the receiver enable pin, \overline{RE} , is logic low, the receiver is enabled. When the differential input voltage defined as $V_{ID} = V_A - V_B$ is higher than the positive input threshold, V_{TH+} , the receiver output, R, turns high. When V_{ID} is lower than the negative input threshold, V_{TH-} , the receiver output, R, turns low. If V_{ID} is between V_{TH+} and V_{TH-} , the output is indeterminate.

When \overline{RE} is logic high or left open, the receiver output is high-impedance and the magnitude and polarity of V_{ID} are irrelevant. Internal biasing of the receiver inputs causes the output to go failsafe-high when the transceiver is disconnected from the bus (open-circuit), or the bus lines are shorted to one another (short-circuit), or the bus is not actively driven (idle bus).

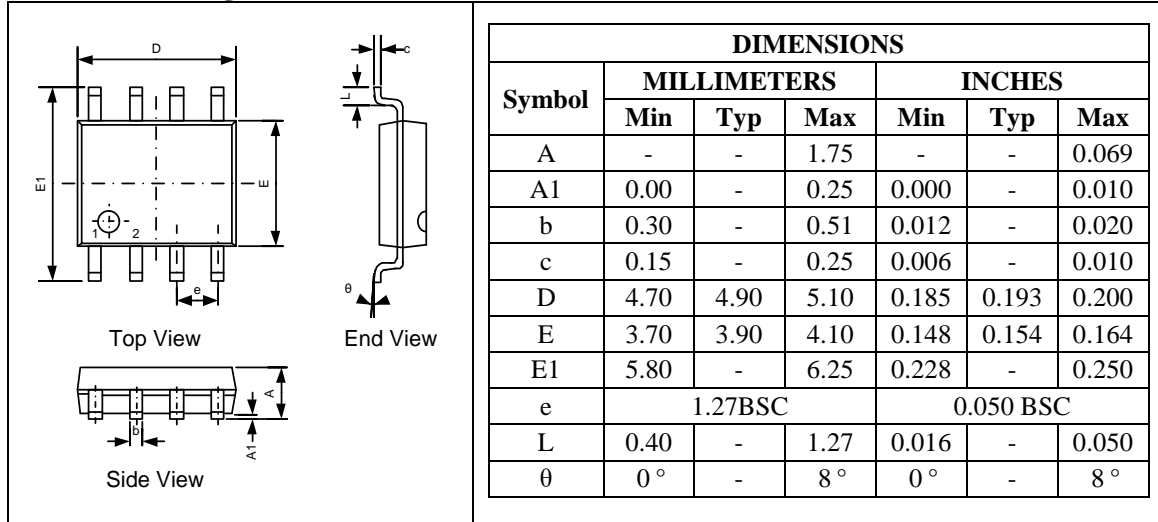
Table 9-2. Driver Function Table

DIFFERENTIAL INPUT	ENABLE	OUTPUTS	FUNCTION
$V_{ID} = V_A - V_B$	\overline{RE}	R	
$V_{TH+} < V_{ID}$	L	H	Receive valid bus high
$V_{TH-} < V_{ID} < V_{TH+}$	L	N/A	Indeterminate bus state
$V_{ID} < V_{TH-}$	L	L	Receive valid bus low
X	H	Z	Receiver disabled
X	OPEN	Z	Receiver disabled by default
Open-circuit bus	L	H	Fail-safe high output
Short-circuit bus	L	H	Fail-safe high output
Idle (terminated) bus	L	H	Fail-safe high output

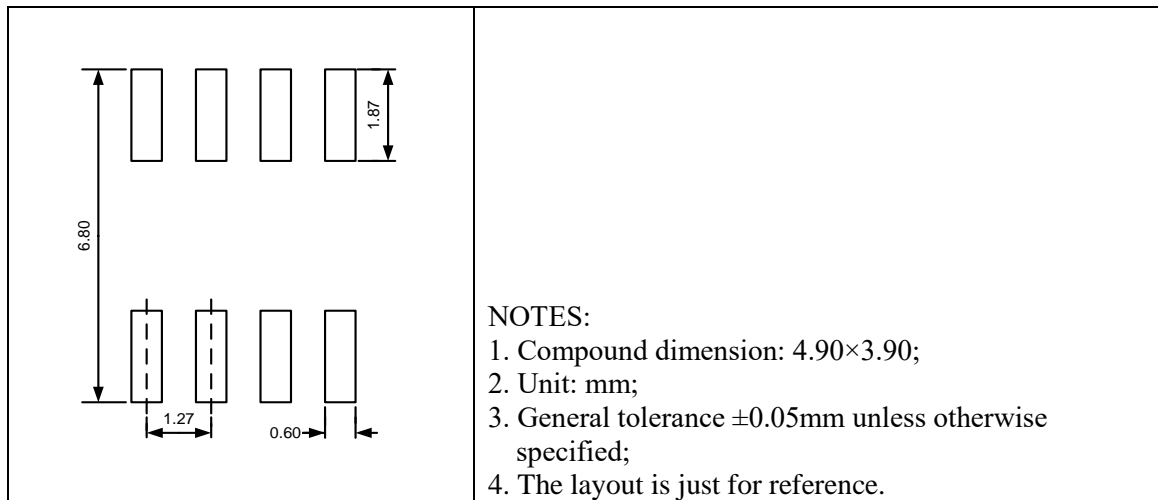
Package Information

SOP8

Outline Drawing

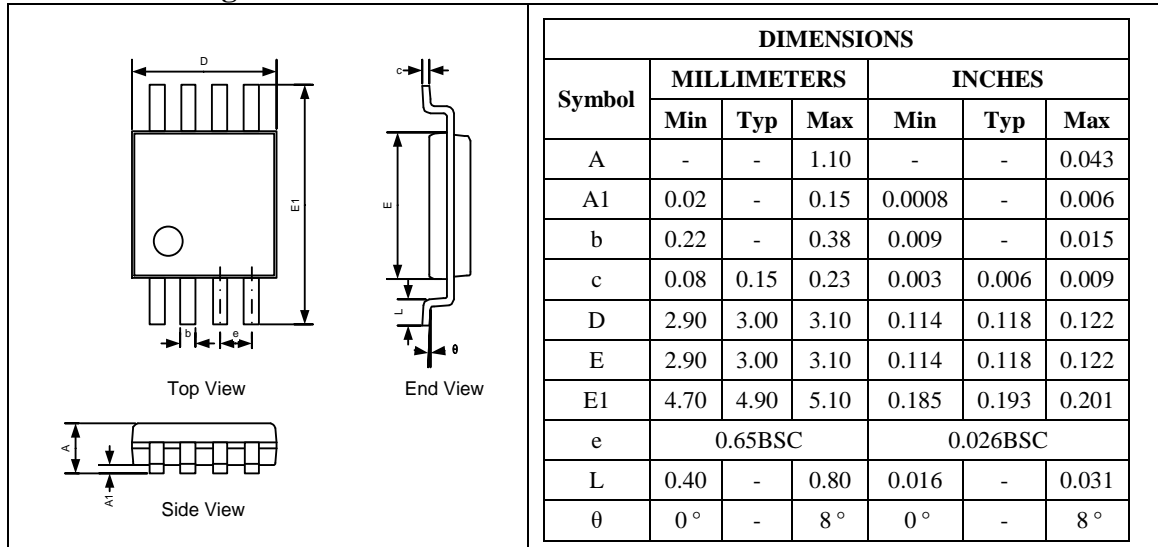


Land Pattern

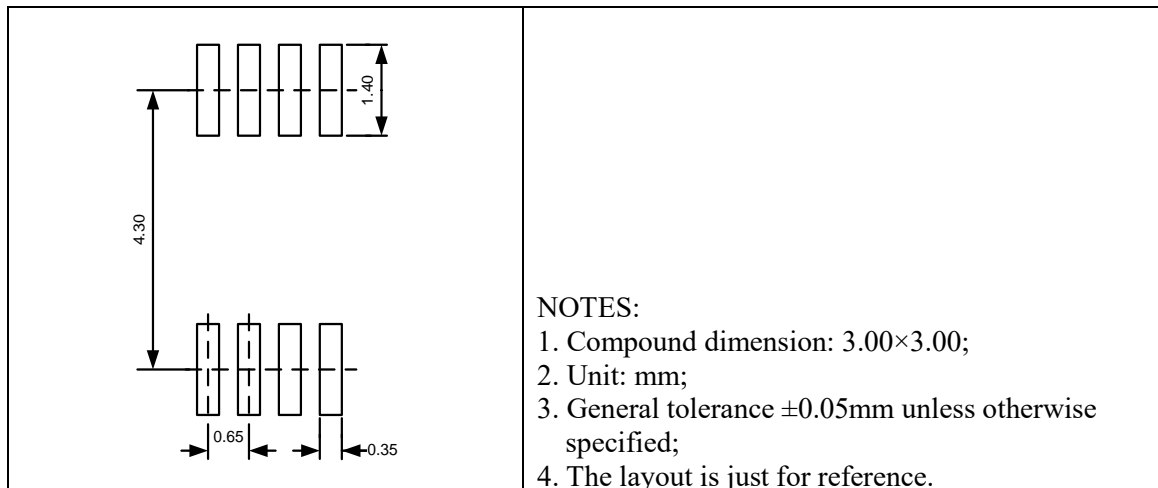


MSOP8

Outline Drawing

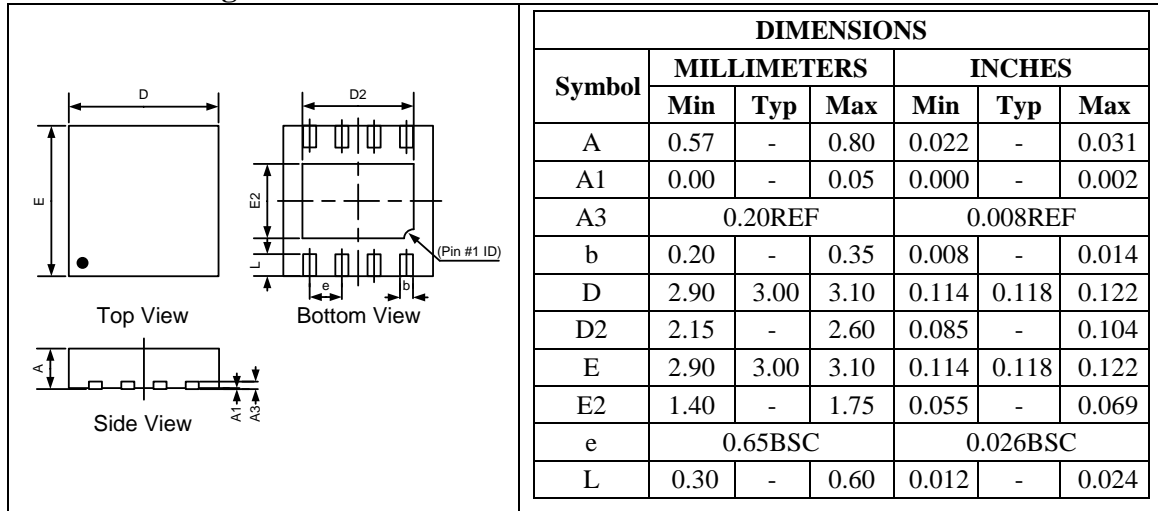


Land Pattern



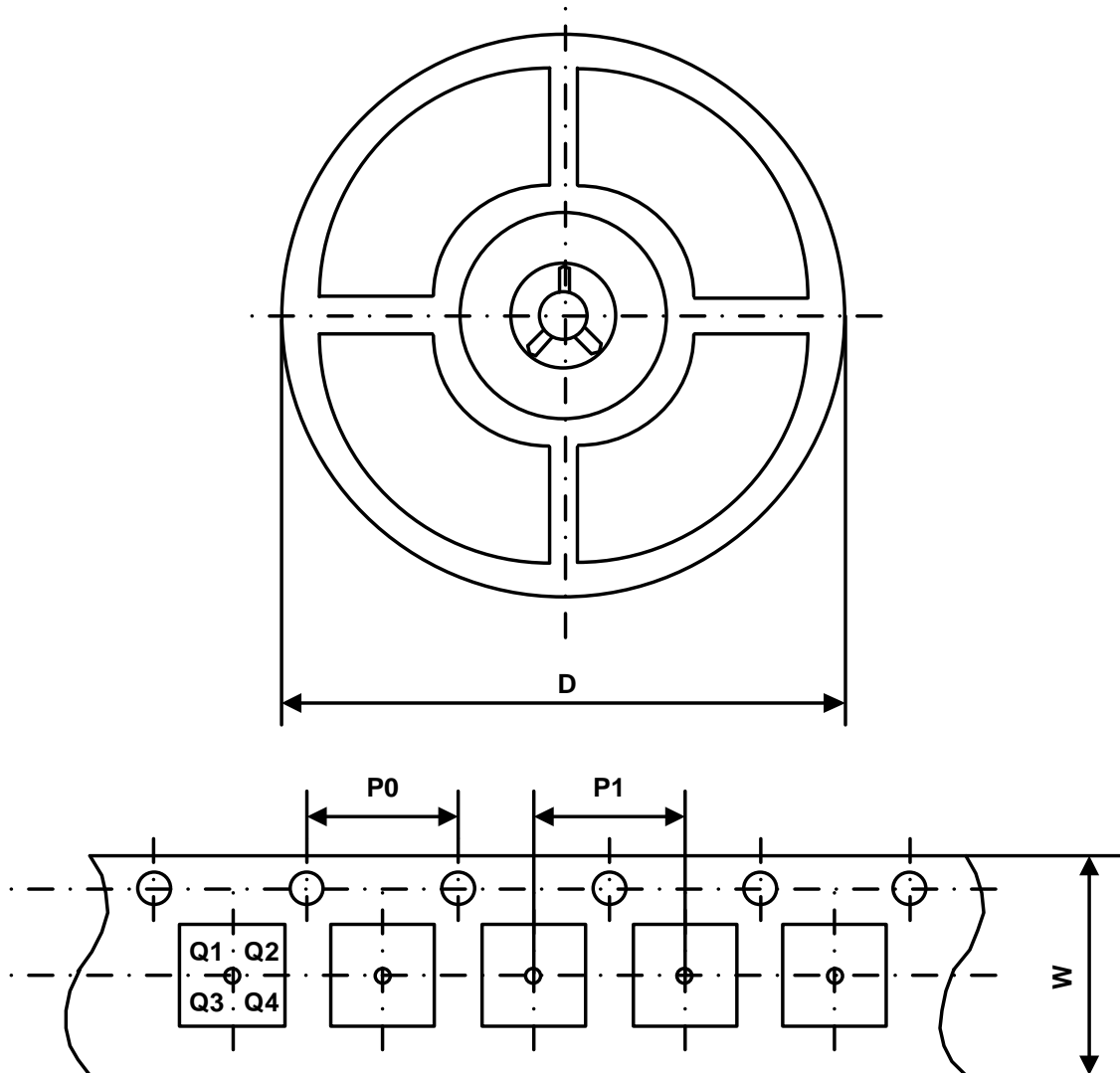
DFN8 3.0×3.0

Outline Drawing



Land Pattern



Packing Information


Part Number	Package Type	Carrier Width (W)	Pitch (P0)	Pitch (P1)	Reel Size (D)	PIN 1 Quadrant
UM13085EESA	SOP8	12 mm	4 mm	8 mm	330 mm	Q1
UM13085EEM8	MSOP8	12 mm	4 mm	8 mm	330 mm	Q1
UM13085EEDA	DFN8 3.0×3.0	12 mm	4 mm	8 mm	330 mm	Q1

GREEN COMPLIANCE

Union Semiconductor is committed to environmental excellence in all aspects of its operations including meeting or exceeding regulatory requirements with respect to the use of hazardous substances. Numerous successful programs have been implemented to reduce the use of hazardous substances and/or emissions.

All Union components are compliant with the RoHS directive, which helps to support customers in their compliance with environmental directives. For more green compliance information, please visit:

<https://www.union-ic.com/Quality.html>

IMPORTANT NOTICE

The information in this document has been carefully reviewed and is believed to be accurate. Nonetheless, this document is subject to change without notice. Union assumes no responsibility for any inaccuracies that may be contained in this document, and makes no commitment to update or to keep current the contained information, or to notify a person or organization of any update. Union reserves the right to make changes, at any time, in order to improve reliability, function or design and to attempt to supply the best product possible.