±70V Bus Fault Protection, CAN FD Transceiver with Silent Mode

UMCAN1051NS8 SOP8
UMCAN1051ES8 SOP8
UMCAN1051VS8 SOP8
UMCAN1051VDA DFN8 3.0×3.0

1 Description

The UMCAN1051 is a high-speed CAN transceiver that provides an interface between a Controller Area Network (CAN) protocol controller and the physical two-wire CAN bus. The transceiver is designed for high-speed CAN applications in the automotive industry, providing differential transmit and receive capability to (a microcontroller with) a CAN protocol controller.

The UMCAN1051 offers improved ElectroMagnetic Compatibility (EMC) and ElectroStatic Discharge (ESD) performance, and also features:

- Ideal passive behavior to the CAN bus when the supply voltage is off.
- UMCAN1051VS8 and UMCAN1051VDA can be interfaced directly to microcontrollers with 3.3V or 5V supply voltage.

The UMCAN1051 implements the CAN physical layer as defined in ISO 11898-2:2024 and SAE J2284-1 to SAE J2284-5. This implementation enables reliable communication in the CAN FD fast phase at data rates up to 5 Mbit/s. These features make the UMCAN1051 an excellent choice for all types of HS-CAN networks, in nodes that do not require a standby mode with wake-up capability via the bus.

2 Applications

- Automotive Industry
- Industrial Control
- Wireless Infrastructure

3 Features

- ISO 11898-2:2024 and SAE J2284-1 to SAE J2284-5 compliant
- Timing guaranteed for data rates up to 5 Mbit/s in the CAN FD fast phase
- Suitable for 12V and 24V systems
- V_{IO} input on UMCAN1051VS8 and UMCAN1051VDA allows for direct interfacing with 3.3V or 5V microcontrollers (available in SOP8 and very small DFN8 packages respectively)
- EN input on UMCAN1051ES8 allows the microcontroller to switch the transceiver to a very low-current Off mode
- Transceiver disengages from the bus when not powered up (zero load)
- High ElectroStatic Discharge (ESD) handling capability on the bus pins
- Transmit Data (TXD) dominant time-out function
- Undervoltage detection on pins V_{CC} and V_{IO}
- Thermally protected

4 Ordering Information

Part Number	Marking Code	Package Type	Shipping Qty
UMCAN1051NS8	1051NS8	SOP8	3000pcs/13Inch Tape & Reel
UMCAN1051ES8	1051ES8	SOP8	3000pcs/13Inch Tape & Reel
UMCAN1051VS8	1051VS8	SOP8	3000pcs/13Inch Tape & Reel
UMCAN1051VDA	1051V	DFN8 3.0×3.0	3000pcs/13Inch Tape & Reel

5 Pin Configuration and Function

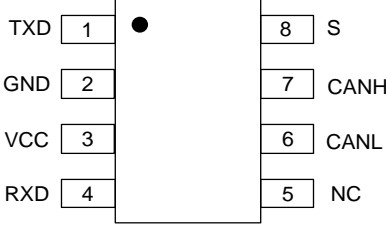
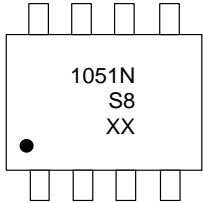
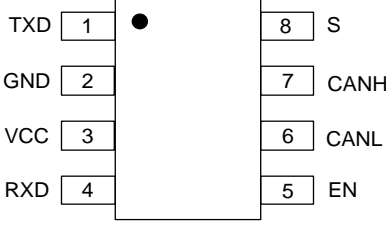
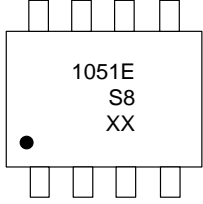
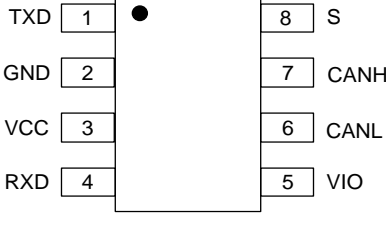
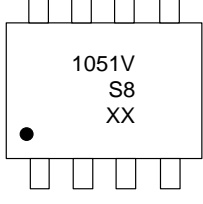
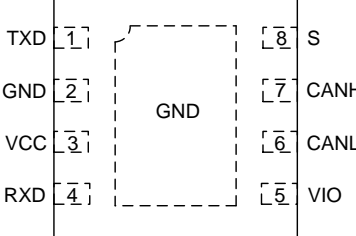
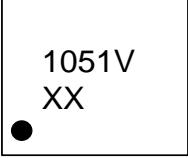
	 <p>XX: Week Code UMCAN1051NS8 SOP8</p>
	 <p>XX: Week Code UMCAN1051ES8 SOP8</p>
	 <p>XX: Week Code UMCAN1051VS8 SOP8</p>
	 <p>XX: Week Code UMCAN1051VDA DFN8 3.0×3.0</p>

5 Pin Configuration and Function (continued)

Table 5-1. Pin Functions

Pin No.	Symbol	Description
1	TXD	Transmit data input
2	GND	Ground (Note1)
3	VCC	Supply voltage
4	RXD	Receive data output; reads out data from the bus lines
5	NC	Not connected; in UMCAN1051NS8 version
	EN	Enable control input; UMCAN1051ES8 only
	V _{IO}	Supply voltage for I/O level adapter; UMCAN1051VS8 and UMCAN1051VDA only
6	CANL	Low-level CAN bus line
7	CANH	High-level CAN bus line
8	S	Silent mode control input

Note 1: DFN8 package die supply ground is connected to both the GND pin and the exposed center pad. The GND pin must be soldered to board ground. For enhanced thermal and electrical performance, it is recommended that the exposed center pad also be soldered to board ground.

6 Specifications

6.1 Recommended Operating Conditions

Symbol	Parameter	Conditions	Min	Typ	Max	Unit
V _{CC}	Bus supply voltage		4.5		5.5	V
V _{IO}	Supply voltage I/O level shifter		2.9		5.5	V
T _A	Operating ambient temperature		-40		125	°C

6.2 Absolute Maximum Ratings (Note 1, 2, 3)

Symbol	Parameter	Conditions	Min	Typ	Max	Unit
V _I	Voltage range on CANH, CANL		-70		+70	V
	Voltage range on V _{CC} , V _{IO}		-0.3		+7	V
	Voltage range on any other pin	Note 4	-0.3		V _{IO} +0.3	V
V _{DIF}	Voltage range between CANH and CANL		-40		+40	V
V _{tr}	Transient voltage on CANH, CANL pins (Note 5)	pulse 1	-100			V
		pulse 2a			+75	V
		pulse 3a	-150			V
		pulse 3b			+100	V
V _{ESD}	Human body model (HBM), per ANSI/ESDA/JEDEC JS-001	All pins		±8		kV
	Contact discharge, per IEC 61000-4-2	Bus pins		±8		kV
I _{LU}	Latch up, per JEDEC JESD78	Class II		200		mA
T _{VJ}	Virtual junction temperature		-40		150	°C
T _{STG}	Storage temperature		-55		150	°C

Note 1: Operation outside the Absolute Maximum Ratings may cause permanent device damage. Absolute Maximum Ratings do not imply functional operation of the device at these or any other conditions beyond those listed under Recommended Operating Conditions. If used outside the Recommended Operating Conditions but within the Absolute Maximum Ratings, the device may not be fully functional, and this may affect device reliability, functionality, performance, and shorten the device lifetime.

Note 2: All voltage values, except differential I/O bus voltages, are with respect to ground terminal.

Note 3: V_{IO} = V_{CC} in non-VIO product variants.

Note 4: Maximum voltage should never exceed 7 V.

Note 5: Verified by an external test house according to IEC TS 62228, Section 4.2.4; parameters for standard pulses defined in ISO 7637.

6.3 Electrical Characteristics (Static) (Note 1)

$T_J = -40^{\circ}\text{C}$ to $+150^{\circ}\text{C}$; $V_{CC} = 4.5\text{V}$ to 5.5V ; $V_{IO} = 2.9\text{V}$ to 5.5V ; $R_L = 60\Omega$; $C_L = 100\text{pF}$ unless otherwise noted; Typical values are at $V_{CC} = 5\text{V}$, $V_{IO} = 3.3\text{V}$, $T_A = 25^{\circ}\text{C}$.

Symbol	Parameter	Conditions	Min	Typ	Max	Unit
Supply; pin VCC						
V_{CC}	Supply voltage		4.5		5.5	V
$V_{UVD(VCC)}$	Undervoltage detection voltage on pin VCC		3	3.6	4.5	V
I_{CC}	Supply current	Off mode (UMCAN1051ES8)			10	μA
		Silent mode		0.8	2.5	mA
		Normal mode; TXD = V_{IO}		4.5	10	mA
		Normal mode; TXD = 0 V	20	45	60	mA
		Normal mode; TXD = 0 V; short circuit on bus lines; $-3\text{V} < (\text{CANH}=\text{CANL}) < 18\text{V}$		73	110	mA
I/O level adapter supply; pin VIO						
V_{IO}	Supply voltage on pin VIO		2.9		5.5	V
$V_{UVD(VIO)}$	Undervoltage detection voltage on pin VIO		1.2	1.5	2.5	V
I_{IO}	Supply current on pin VIO	Normal mode; TXD = 0V		80	300	μA
		Normal mode; TXD = V_{IO}		15	50	μA
		Silent mode		15	50	μA
Mode control inputs; pins S and EN (Note2)						
V_{IH}	High-level input voltage		$0.7V_{IO}$			V
V_{IL}	Low-level input voltage				$0.3V_{IO}$	V
I_{IH}	High-level input current	$V_{IN} = V_{IO}$	1		10	μA
I_{IL}	Low-level input current	$V_{IN} = 0\text{V}$	-1		-1	μA

6.3 Electrical Characteristics (Static)---continued (Note 1)

$T_J = -40^{\circ}\text{C}$ to $+150^{\circ}\text{C}$; $V_{CC} = 4.5\text{V}$ to 5.5V ; $V_{IO} = 2.9\text{V}$ to 5.5V ; $R_L = 60\Omega$; $C_L = 100\text{pF}$ unless otherwise noted; Typical values are at $V_{CC} = 5\text{V}$, $V_{IO} = 3.3\text{V}$, $T_A = 25^{\circ}\text{C}$.

Symbol	Parameter	Conditions	Min	Typ	Max	Unit
CAN transmit data input; pin TXD						
V_{IH}	High-level input voltage		$0.7V_{IO}$			V
V_{IL}	Low-level input voltage				$0.3V_{IO}$	V
I_{IH}	High-level input current	$V_{IN} = V_{IO}$	-5		5	μA
I_{IL}	Low-level input current	$V_{IN} = 0\text{V}$	-270	-60	-30	μA
C_I	Input capacitance			5	10	pF
CAN receive data output; pin RXD						
I_{OH}	High-level output current	$\text{RXD} = V_{IO} - 0.4\text{V}$	-9	-3	-1	mA
I_{OL}	Low-level output current	$\text{RXD} = 0.4\text{V}$	1	3	12	mA
Driver						
$V_{O(\text{DOM})}$	Dominant output voltage	$S = 0\text{V}$; $\text{TXD} = 0\text{V}$; $t < t_{\text{TO}(\text{DOM})\text{TXD}}$; $V_{CC} = 4.75\text{V}$ to 5.25V				
		$50\Omega \leq R_L \leq 65\Omega$; pin CANH	2.75	3.5	4.5	V
		$50\Omega \leq R_L \leq 65\Omega$; pin CANL	0.5	1.5	2.25	V
$V_{\text{OD}(\text{DOM})}$	Dominant differential output voltage	$S = 0\text{V}$; $\text{TXD} = 0\text{V}$; $t < t_{\text{TO}(\text{DOM})\text{TXD}}$; $V_{CC} = 4.75\text{V}$ to 5.25V				
		$50\Omega \leq R_L \leq 65\Omega$;	1.5		3	V
		$45\Omega \leq R_L \leq 70\Omega$;	1.4		3.3	V
		$R_L = 2240\Omega$;	1.5		5	V
$V_{\text{O}(\text{REC})}$	Recessive output voltage	Normal or silent mode; $\text{TXD} = V_{IO}$; $R_L = \text{open}$	2	$0.5V_{CC}$	3	V
$V_{\text{OD}(\text{REC})}$	Recessive differential output voltage	Normal or silent mode; $\text{TXD} = V_{IO}$; $R_L = \text{open}$	-50		50	mV
$V_{\text{SYM}(\text{DOM})}$	Dominant output voltage symmetry, V_{CC} -CANH-CANL	$\text{TXD} = 0\text{V}$; $t < t_{\text{TO}(\text{DOM})\text{TXD}}$; $R_L = 60\Omega$	-400		400	mV

6.3 Electrical Characteristics (Static)---continued (Note 1)

$T_J = -40^{\circ}\text{C}$ to $+150^{\circ}\text{C}$; $V_{CC} = 4.5\text{V}$ to 5.5V ; $V_{IO} = 2.9\text{V}$ to 5.5V ; $R_L = 60\Omega$; $C_L = 100\text{pF}$ unless otherwise noted; Typical values are at $V_{CC} = 5\text{V}$, $V_{IO} = 3.3\text{V}$, $T_A = 25^{\circ}\text{C}$.

Symbol	Parameter	Conditions	Min	Typ	Max	Unit
$V_{\text{SYM(TX)}}$	Transmitter output voltage symmetry, $(\text{CANH}+\text{CANL})/V_{CC}$	$\text{TXD} = 250\text{ kHz}, 1\text{ MHz}, 2.5\text{MHz}$; $R_L = 60\ \Omega$; $C_{\text{SPLIT}} = 4.7\text{ nF}$; see Figure 7-2	$0.9V_{CC}$		$1.1V_{CC}$	V
$I_{\text{OS(DOM)}}$	Dominant short-circuit output current	$\text{TXD} = 0\text{ V}$; $t < t_{\text{TO(DOM)TXD}}$; $V_{CC} = 5\text{ V}$; $\text{CANH} = -15\text{ V}$ to 40 V ; pin CANH	-100	-70		mA
		$\text{TXD} = 0\text{ V}$; $t < t_{\text{TO(DOM)TXD}}$; $V_{CC} = 5\text{ V}$; $\text{CANL} = -15\text{ V}$ to 40 V ; pin CANL		70	100	mA
$I_{\text{OS(REC)}}$	Recessive short-circuit output current	Normal mode; $\text{TXD} = V_{IO}$; $-27\text{ V} \leq \text{CANH} = \text{CANL} \leq 32\text{ V}$	-5		5	mA
Receiver						
V_{TH}	Differential receiver threshold voltage	Normal or silent mode; $-30\text{ V} \leq \text{CANH}, \text{CANL} \leq 30\text{ V}$	0.5		0.9	V
$V_{\text{ID(REC)}}$	Receiver recessive voltage	Normal or silent mode; $-30\text{ V} \leq \text{CANH}, \text{CANL} \leq 30\text{ V}$	-4		0.5	V
$V_{\text{ID(DOM)}}$	Receiver dominant voltage	Normal or silent mode; $-30\text{ V} \leq \text{CANH}, \text{CANL} \leq 30\text{ V}$	0.9		9	V
V_{HYS}	Differential receiver hysteresis voltage	Normal or silent mode; $-30\text{ V} \leq \text{CANH}, \text{CANL} \leq 30\text{ V}$	50		300	mV
$I_{\text{LKG(PD)}}$	Unpowered Leakage current	$V_{CC} = V_{IO} = 0\text{ V}$ or shorted to GND via $47\text{ k}\Omega$; $\text{CANH} = \text{CANL} = 5\text{ V}$	-5		5	μA
R_I	Input resistance	$-2\text{ V} \leq \text{CANH}, \text{CANL} \leq 7\text{ V}$	15	30	40	$\text{k}\Omega$
ΔR_I	Input resistance deviation, $[1 - (R_{\text{IN(CANH)}}/R_{\text{IN(CANL)}})] \times 100\%$	$0\text{ V} \leq \text{CANH}, \text{CANL} \leq 5\text{ V}$	-3		3	%
R_{ID}	Differential input resistance	$-2\text{ V} \leq \text{CANH}, \text{CANL} \leq 7\text{ V}$	30	60	80	$\text{k}\Omega$
C_{IN}	Common-mode input capacitance to ground				20	pF

6.3 Electrical Characteristics (Static)---continued (Note 1)

$T_J = -40^{\circ}\text{C}$ to $+150^{\circ}\text{C}$; $V_{CC} = 4.5\text{V}$ to 5.5V ; $V_{IO} = 2.9\text{V}$ to 5.5V ; $R_L = 60\Omega$; $C_L = 100\text{pF}$ unless otherwise noted; Typical values are at $V_{CC} = 5\text{V}$, $V_{IO} = 3.3\text{V}$, $T_A = 25^{\circ}\text{C}$.

Symbol	Parameter	Conditions	Min	Typ	Max	Unit
C_{ID}	Differential input capacitance				10	pF
Thermal Protection						
$T_{J(SD)}$	Shutdown junction temperature			185		$^{\circ}\text{C}$

Note 1: $V_{IO} = V_{CC}$ in non-VIO product variants.

Note 2: Only UMCAN1051ES8 has an EN pin.

6.4 Electrical Characteristics (Dynamic) (Note 1)

$T_J = -40^{\circ}\text{C}$ to $+150^{\circ}\text{C}$; $V_{CC} = 4.5\text{V}$ to 5.5V ; $V_{IO} = 2.9\text{V}$ to 5.5V ; $R_L = 60\Omega$; $C_L = 100\text{pF}$ unless otherwise noted; Typical values are at $V_{CC} = 5\text{V}$, $V_{IO} = 3.3\text{V}$, $T_A = 25^{\circ}\text{C}$.

Symbol	Parameter	Conditions	Min	Typ	Max	Unit
CAN timing characteristics; $t_{\text{BIT(TXD)}} \geq 200\text{ ns}$; see Figure 7-1, Figure 7-3						
$t_{\text{D(TXD-BUSDOM)}}$	Delay time from TXD to bus dominant	Normal mode; $R_L = 60\Omega$, $C_L = 100\text{ pF}$		51	90	ns
$t_{\text{D(TXD-BUSREC)}}$	Delay time from TXD to bus recessive	Normal mode; $R_L = 60\Omega$, $C_L = 100\text{ pF}$		48	90	ns
$t_{\text{D(BUSDOM-RXD)}}$	Delay time from bus dominant to RXD	Normal mode; $C_{\text{L(RXD)}} = 15\text{ pF}$		51	100	ns
$t_{\text{D(BUSREC-RXD)}}$	Delay time from bus recessive to RXD	Normal mode; $C_{\text{L(RXD)}} = 15\text{ pF}$		56	110	ns
$t_{\text{D(TXDL-RXDL)}}$	Delay time from TXD LOW to RXD LOW	Normal mode; $R_L = 60\Omega$, $C_L = 100\text{ pF}$, $C_{\text{L(RXD)}} = 15\text{ pF}$	50		195	ns
$t_{\text{D(TXDH-RXDH)}}$	Delay time from TXD HIGH to RXD HIGH	Normal mode; $R_L = 60\Omega$, $C_L = 100\text{ pF}$, $C_{\text{L(RXD)}} = 15\text{ pF}$	50		195	ns
CAN FD timing characteristics according to ISO 11898-2:2024 parameter set B ($t_{\text{BIT(TXD)}} \geq 200\text{ ns}$, up to 5 Mbit/s); See figure 7-1 and figure 7-3						
$\Delta t_{\text{BIT(BUS)}}$	Transmitted recessive bit width deviation	$\Delta t_{\text{BIT(BUS)}} = t_{\text{BIT(BUS)}} - t_{\text{BIT(TXD)}}$	-45		10	ns
Δt_{REC}	Receiver timing symmetry	$\Delta t_{\text{REC}} = t_{\text{BIT(RXD)}} - t_{\text{BIT(BUS)}}$	-45		15	ns
$\Delta t_{\text{BIT(RXD)}}$	Received recessive bit width deviation	$\Delta t_{\text{BIT(RXD)}} = t_{\text{BIT(RXD)}} - t_{\text{BIT(TXD)}}$	-80		20	ns
CAN FD timing characteristics according to ISO 11898-2:2024 parameter set A ($t_{\text{BIT(TXD)}} \geq 500\text{ ns}$, up to 2 Mbit/s); See figure 7-1 and figure 7-3						
$\Delta t_{\text{BIT(BUS)}}$	Transmitted recessive bit width deviation	$\Delta t_{\text{BIT(BUS)}} = t_{\text{BIT(BUS)}} - t_{\text{BIT(TXD)}}$	-65		30	ns
Δt_{REC}	Receiver timing symmetry	$\Delta t_{\text{REC}} = t_{\text{BIT(RXD)}} - t_{\text{BIT(BUS)}}$	-65		40	ns
$\Delta t_{\text{BIT(RXD)}}$	Received recessive bit width deviation	$\Delta t_{\text{BIT(RXD)}} = t_{\text{BIT(RXD)}} - t_{\text{BIT(TXD)}}$	-100		50	ns
$t_{\text{TO(DOM)TXD}}$	TXD dominant time-out time	Normal mode; TXD = 0V (Note 2)	0.8	2.6	6.5	ms

Note 1: $V_{IO} = V_{CC}$ in non-VIO product variants.

Note 2: Time-out occurs between the min and max values. Time-out is guaranteed not to occur below the min value; time-out is guaranteed to occur above the max value.

7 Parameter Measurement Information

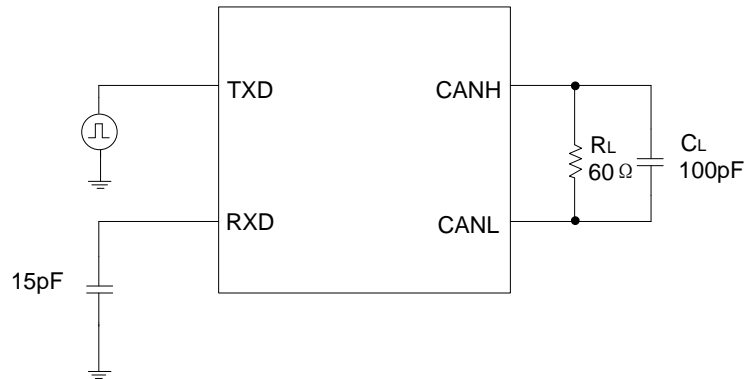

Figure 7-1. CAN transceiver timing test circuit

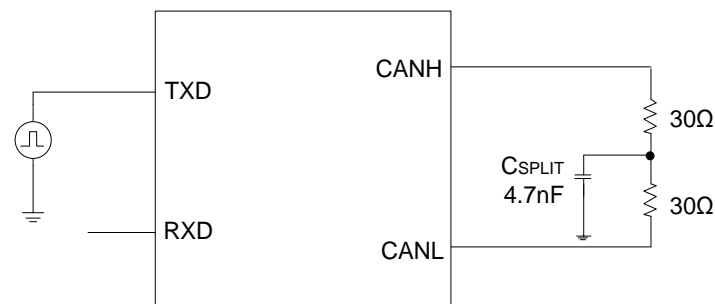

Figure 7-2. Test circuit for measuring transceiver transmitter driver symmetry

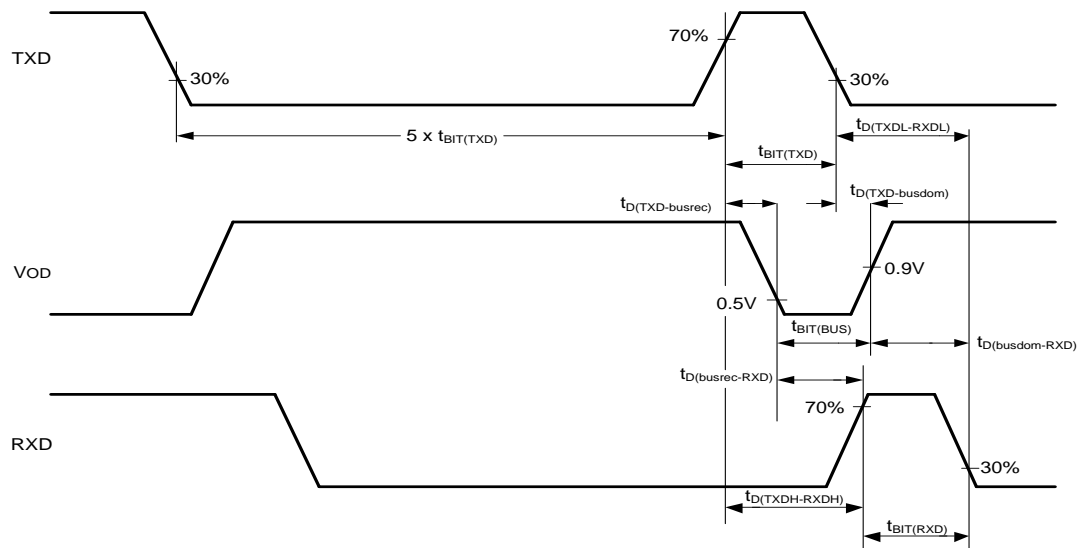

Figure 7-3. CAN FD timing definitions according to ISO 11898-2:2024

8 Block diagram

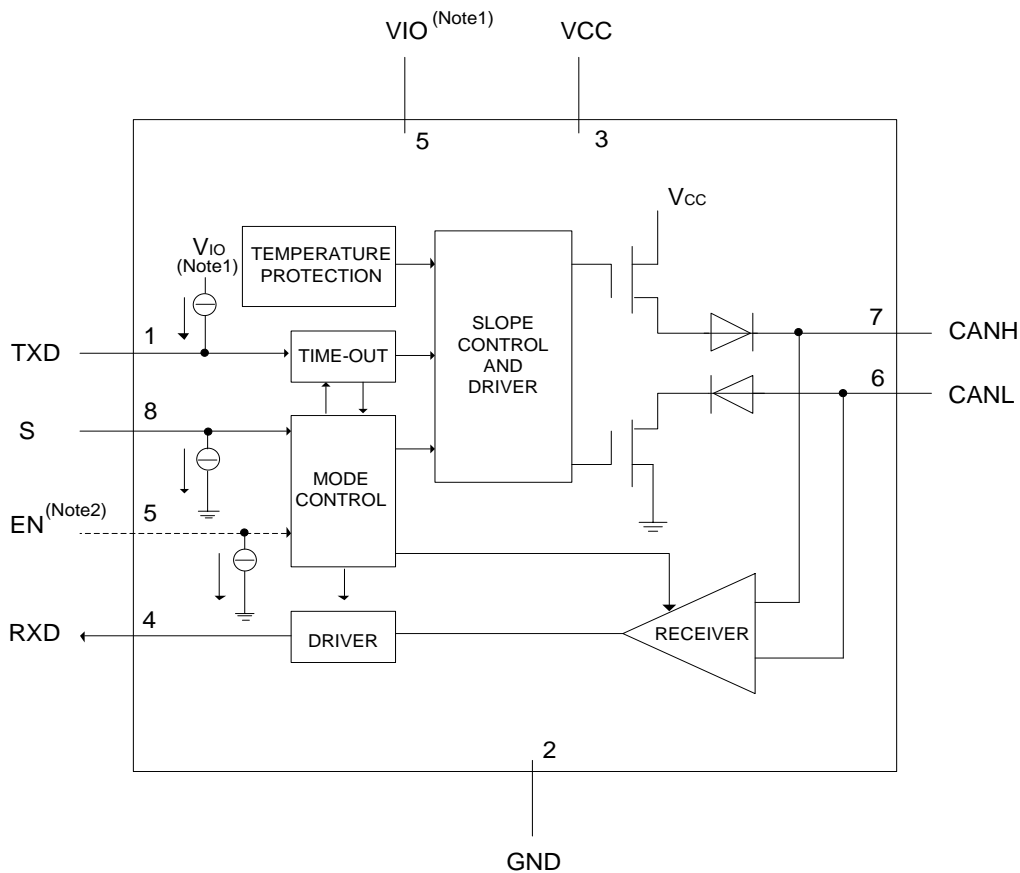

Figure 8-1. Block diagram

Note 1: $V_{IO} = V_{CC}$ in non-VIO product variants.

Note 2: Only present in the UMCAN1051ES8.

9 Detailed Description

9.1 Functional Description

The UMCAN1051 is a high-speed CAN stand-alone transceiver with Silent mode. It combines the functionality of transceiver with improved EMC and ESD handling capability. Improved slope control and high DC handling capability on the bus pins provides additional application flexibility. The UMCAN1051 is available in three versions, distinguished only by the function of pin 5:

- The UMCAN1051VS8 and UMCAN1051VDA allow for direct interfacing to microcontrollers with supply voltages down to 3.3 V.
- The UMCAN1051ES8 allows the transceiver to be switched to a very low-current Off mode.
- The UMCAN1051NS8 has the NC pin. This pin is not connected internally. It is a reserved pin intended for package/pinout compatibility or potential future feature expansion.

9.2 Operating modes

The UMCAN1051 supports two operating modes, Normal and Silent, which are selected via pin S. An additional Off mode is supported in the UMCAN1051ES8 via pin EN. See Table 1 for a description of the operating modes under normal supply conditions.

Table 9-1. Operating modes

Mode	Inputs			Outputs	
	Pin EN (Note 1)	Pin S	Pin TXD	CAN driver	Pin RXD
Normal	HIGH	LOW	LOW	dominant	Active (Note 2)
	HIGH	LOW	HIGH	recessive	Active (Note 2)
Silent	HIGH	HIGH	X (Note)	recessive	Active (Note 2)
Off (Note 1)	LOW	X (Note 3)	X (Note 3)	floating	floating

Note 1: Only available on the UMCAN1051ES8.

Note 2: LOW if the CAN bus is dominant, HIGH if the CAN bus is recessive.

Note 3: 'X' = Don't care.

9.2.1 Normal mode

A LOW level on pin S selects Normal mode. In this mode, the transceiver is able to transmit and receive data via the bus lines CANH and CANL (see Figure 8-1 for the block diagram). The differential receiver converts the analog data on the bus lines into digital data which is output to pin RXD. The slopes of the output signals on the bus lines are controlled internally and are optimized in a way that guarantees the lowest possible ElectroMagnetic Emission (EME).

9.2.2 Silent mode

A HIGH level on pin S selects Silent mode. In Silent mode the transmitter is disabled, releasing the bus pins to recessive state. All other IC functions, including the receiver, continue to operate as in Normal mode. Silent mode can be used to prevent a faulty CAN controller from disrupting all network communications.

9.2.3 Off mode

A LOW level on pin EN of UMCAN1051ES8 selects Off mode. In Off mode the entire transceiver is disabled, allowing the microcontroller to save power when CAN communication is not required. The bus pins are floating in Off mode, making the transceiver invisible to the rest of the network.

9.3 Fail-Safe Features

9.3.1 TXD dominant time-out function

A ‘TXD dominant time-out’ timer is started when pin TXD is set LOW. If the LOW state on pin TXD persists for longer than $t_{TO(DOM)TXD}$, the transmitter is disabled, releasing the bus lines to recessive state. This function prevents a hardware and/or software application failure from driving the bus lines to a permanent dominant state (blocking all network communications). The TXD dominant time-out timer is reset when pin TXD is set HIGH.

9.3.2 Internal biasing of TXD, S and EN input pins

Pin TXD has an internal pull-up to V_{IO} and pins S and EN (UMCAN1051ES8) have internal pull-downs to GND. This ensures a safe, defined state in case one or more of these pins is left floating.

9.3.3 Undervoltage detection on pins VCC and VIO

Should V_{CC} or V_{IO} drop below their respective undervoltage detection levels ($V_{uvd(VCC)}$ and $V_{uvd(VIO)}$), the transceiver will switch off and disengage from the bus (high-impedance) until V_{CC} and V_{IO} have recovered.

9.3.4 Overtemperature protection

The output drivers are protected against overtemperature conditions. If the operating junction temperature exceeds the shutdown junction temperature, $T_{J(SD)}$, the output drivers will be disabled until the operating junction temperature falls below $T_{J(SD)}$ and TXD becomes recessive again. Including the TXD condition ensures that output driver oscillations due to temperature drift are avoided.

9.3.5 VIO supply pin

There are three versions of the UMCAN1051 available, only differing in the function of a single pin. Pin 5 is either an enable control input (EN), a V_{IO} supply pin or is not connected. Pin V_{IO} on the UMCAN1051VS8 and UMCAN1051VDA should be connected to the microcontroller supply voltage (see Figure 10-2). This will adjust the signal levels of pins TXD, RXD and S to the I/O levels of the microcontroller. For versions of the UMCAN1051 without a V_{IO} pin, the V_{IO} input is internally connected to V_{CC} . This sets the signal levels of pins TXD, RXD and S to levels compatible with 5V microcontrollers.

10 Application Information

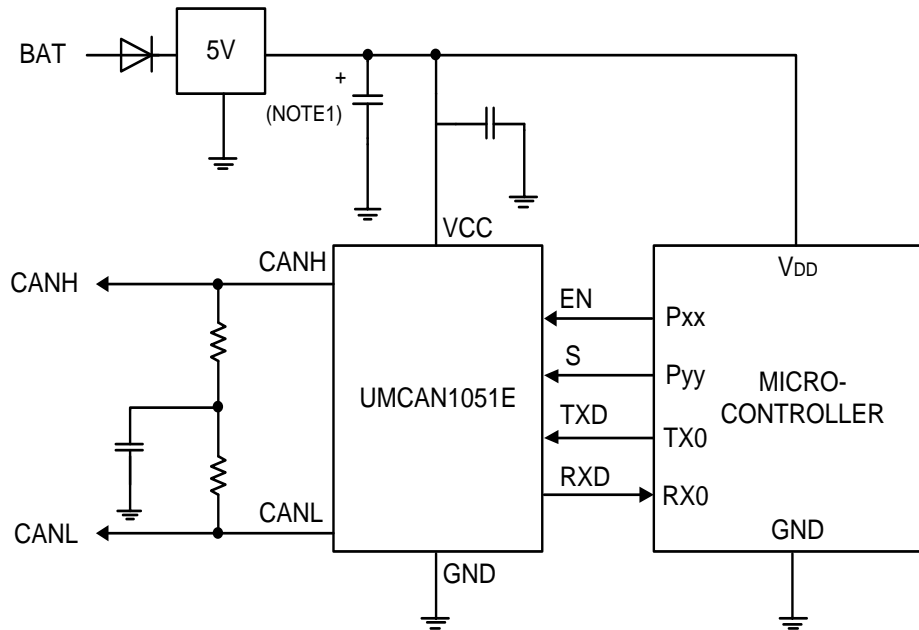

Figure 10-1. Typical application of the UMCAN1051E

Note1: Optional, depends on regulator

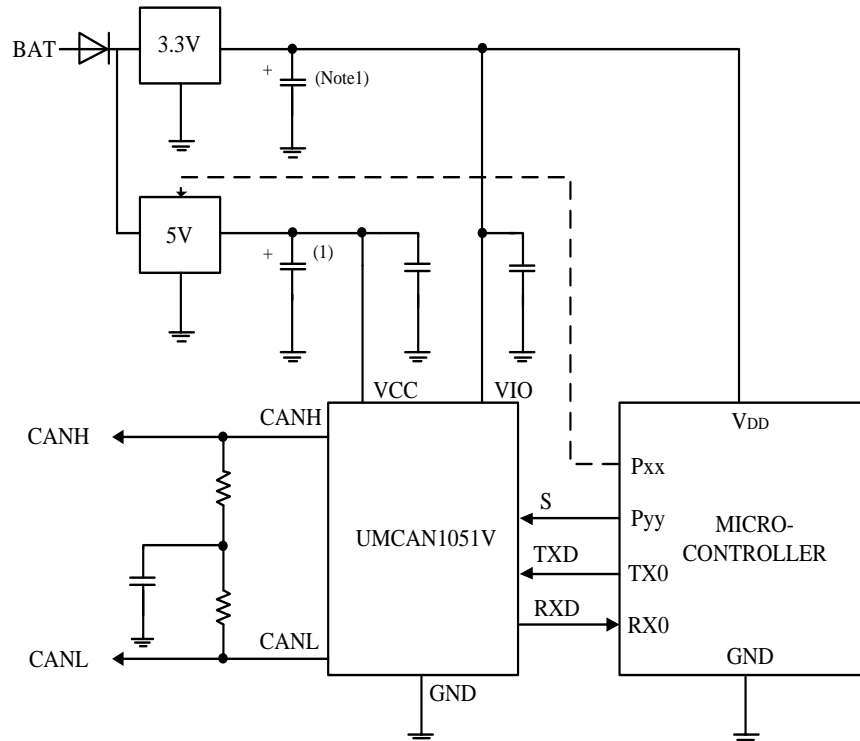

Figure 10-2. Typical application of the UMCAN1051V

Note1: Optional, depends on regulator

Package Information

SOP8

Outline Drawing

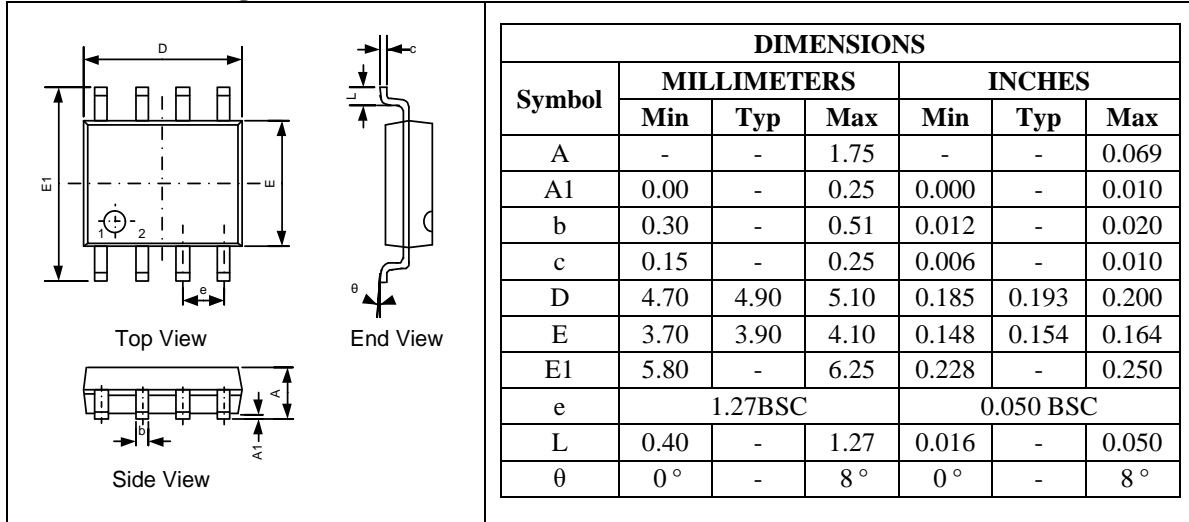

Land Pattern

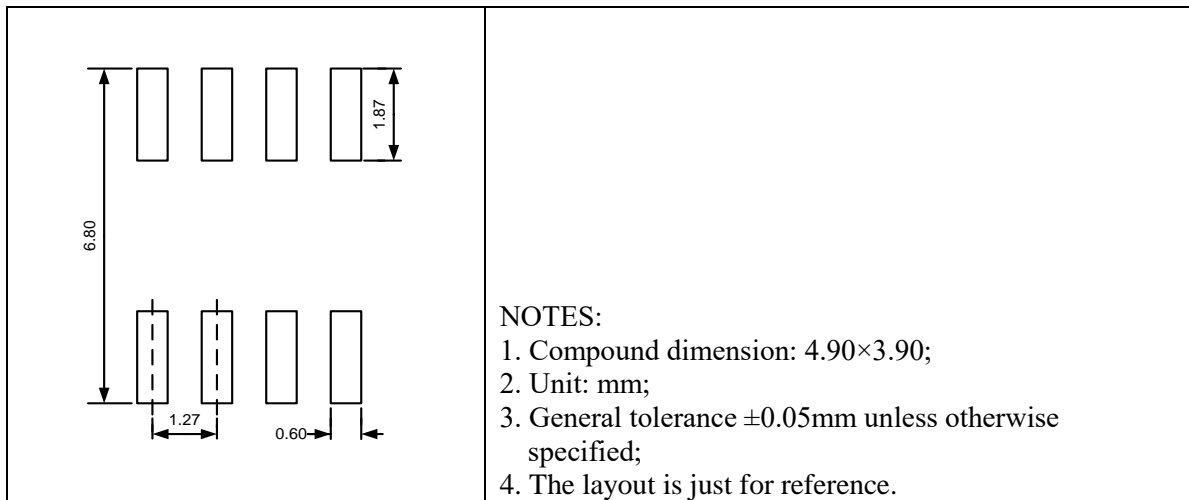

DFN8 3.0×3.0

Outline Drawing

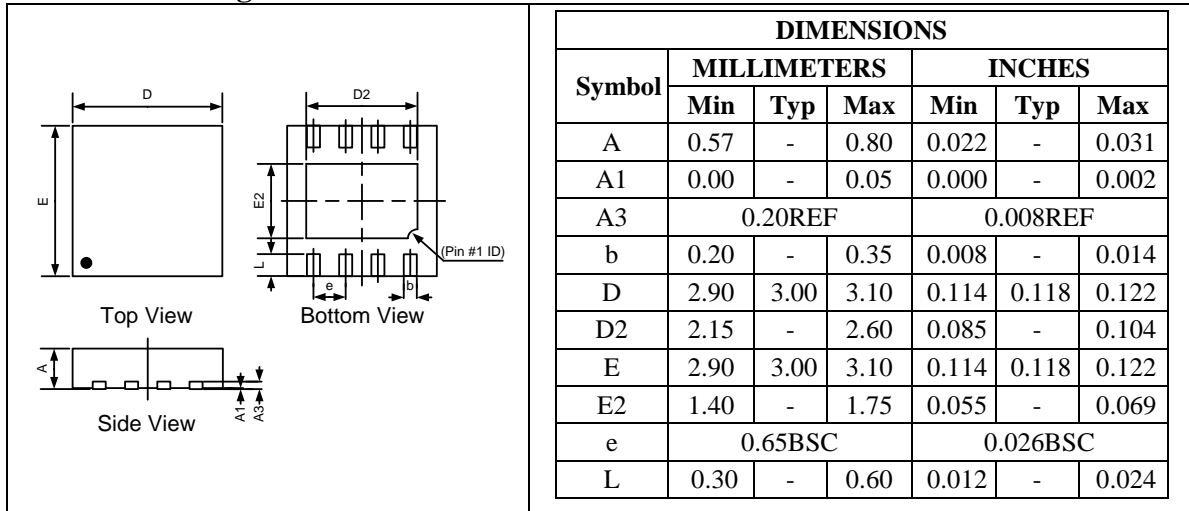

Land Pattern

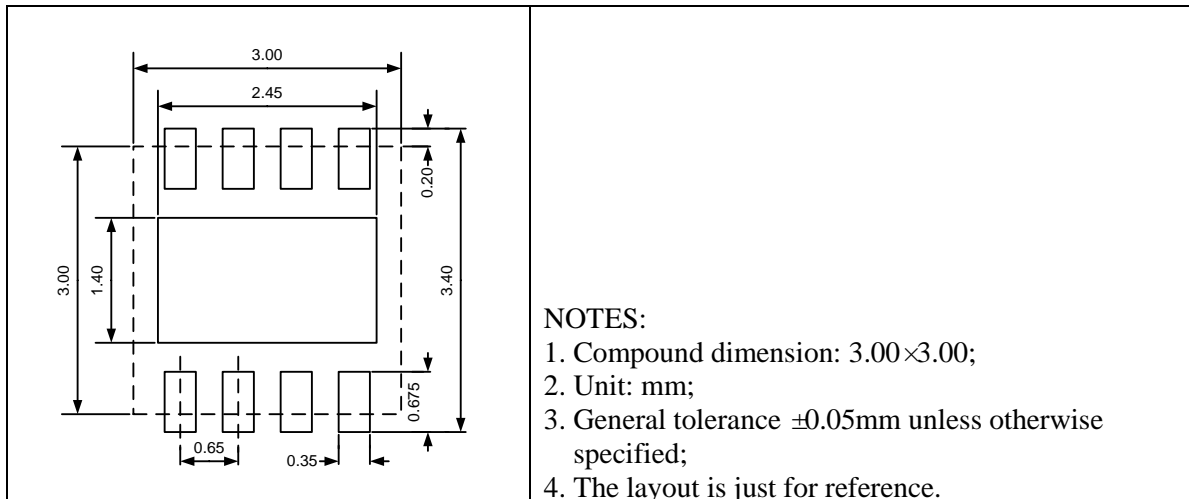

Packing Information

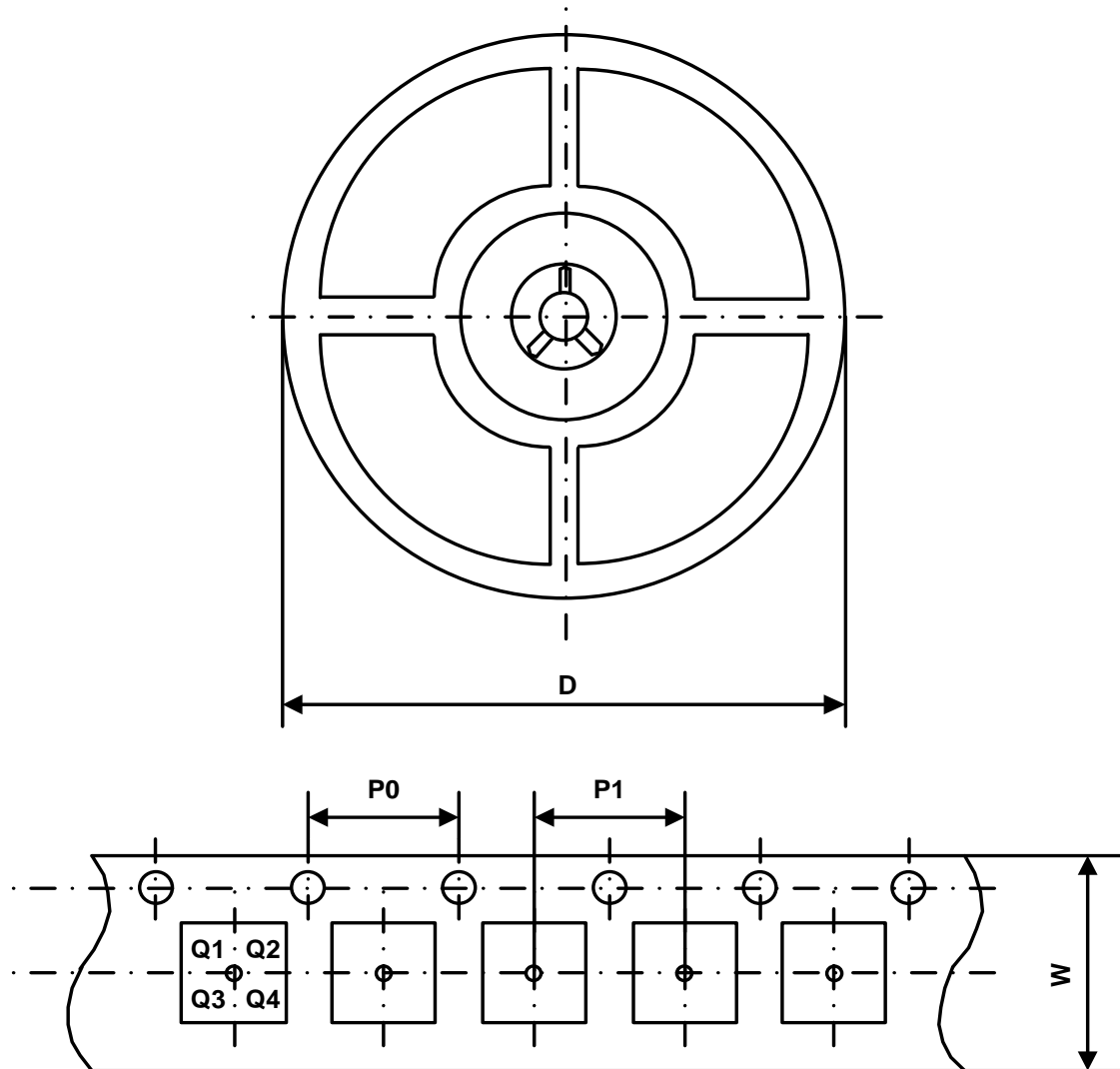

Part Number	Package Type	Carrier Width (W)	Pitch (P0)	Pitch (P1)	Reel Size (D)	PIN 1 Quadrant
UMCAN1051NS8	SOP8	12 mm	4 mm	8 mm	330 mm	Q1
UMCAN1051ES8	SOP8	12 mm	4 mm	8 mm	330 mm	Q1
UMCAN1051VS8	SOP8	12 mm	4 mm	8 mm	330 mm	Q1
UMCAN1051VDA	DFN8 3.0×3.0	12 mm	4 mm	8 mm	330 mm	Q1

GREEN COMPLIANCE

Union Semiconductor is committed to environmental excellence in all aspects of its operations including meeting or exceeding regulatory requirements with respect to the use of hazardous substances. Numerous successful programs have been implemented to reduce the use of hazardous substances and/or emissions.

All Union components are compliant with the RoHS directive, which helps to support customers in their compliance with environmental directives. For more green compliance information, please visit:

<https://www.union-ic.com/Quality.html>

IMPORTANT NOTICE

The information in this document has been carefully reviewed and is believed to be accurate. Nonetheless, this document is subject to change without notice. Union assumes no responsibility for any inaccuracies that may be contained in this document, and makes no commitment to update or to keep current the contained information, or to notify a person or organization of any update. Union reserves the right to make changes, at any time, in order to improve reliability, function or design and to attempt to supply the best product possible.