

4-Bit Dual-Supply Bus Transceiver With Configurable Voltage-Level Shifting and 3-State Outputs With Independent Direction Control Inputs

UM74AVC4T774SG SOP16
UM74AVC4T774UG TSSOP16
UM74AVC4T774QA QFN16 2.6×1.8
UM74AVC4T774QB QFN16 2.5×3.5
UM74AVC4T774QC QFN16 4.0×3.5

1 Description

The UM74AVC4T774 is a 4-bit, dual supply transceiver that enables bidirectional level translation. It features four direction control inputs (DIR1, DIR2, DIR3 and DIR4), an output enable input (\overline{OE}) and dual supply pins (V_{CCA} and V_{CCB}). Both V_{CCA} and V_{CCB} can be supplied at any voltage between 1.0 V and 3.6 V making the device suitable for translating between any of the low voltage nodes (1.0 V, 1.2 V, 1.5 V, 1.8 V, 2.5 V and 3.3 V). Pins An, \overline{OE} and DIRn are referenced to V_{CCA} and pins Bn are referenced to V_{CCB} . A High on DIRn allows transmission from An to Bn and a Low on DIRn allows transmission from Bn to An. The output enable input \overline{OE} can be used to disable the outputs so the buses are effectively isolated.

The device is fully specified for partial power-down applications using I_{OFF} . The I_{OFF} circuitry disables the output, preventing any damaging backflow current through the device when it is powered down. In suspend mode when either V_{CCA} or V_{CCB} are at GND level, both An and Bn are in the high-impedance Off-state. The V_{CC} isolation feature is designed so that if either V_{CC} input supply is below 100mV, all level shifter outputs are disabled and placed into a high impedance state. To put the device into the high-impedance state during power up or power down, tie \overline{OE} to V_{CC} through a pull-up resistor; the current-sinking capability of the driver determines the minimum value of the resistor.

The UM74AVC4T774 series are available in QFN16 2.6×1.8, QFN16 2.5×3.5, QFN16 4.0×3.5, SOP16 and TSSOP16 packages.

2 Features

- Each Channel Has an Independent DIR Control Input
- I_{OFF} supports partial power-down mode operation
- V_{CC} isolation feature – if either V_{CC} input is at GND, all are in the high-impedance state
- Control Inputs V_{IH}/V_{IL} Levels Are Referenced to V_{CCA} Voltage
- Fully Configurable Dual-Rail Design Allows Each Port to Operate Over the Full 1.0 V to 3.6 V Power-Supply Range
- Up to 400Mbps support when translating from 1.8V to 3.3V
- Latch-Up Performance exceeds 200 mA per JESD 78
- ESD Protection on A and B ports
 - ± 8 kV Human body model
 - ± 2 kV Charged-device model

3 Applications

- Personal electronic
- Enterprise
- Industrial
- Telecom

4 Ordering Information

Part Number	Mark Code	Package Type	Shipping Qty
UM74AVC4T774SG	AVC4T774	SOP16	2500pcs/13Inch Tape & Reel
UM74AVC4T774UG	AVC4T774	TSSOP16	3000pcs/13Inch Tape & Reel
UM74AVC4T774QA	ABF	QFN16 2.6×1.8	3000pcs/7Inch Tape & Reel
UM74AVC4T774QB	AQC	QFN16 2.5×3.5	6000pcs/13Inch Tape & Reel
UM74AVC4T774QC	AVC4T774	QFN16 4.0×3.5	3000pcs/13Inch Tape & Reel

5 Pin Configuration and Function

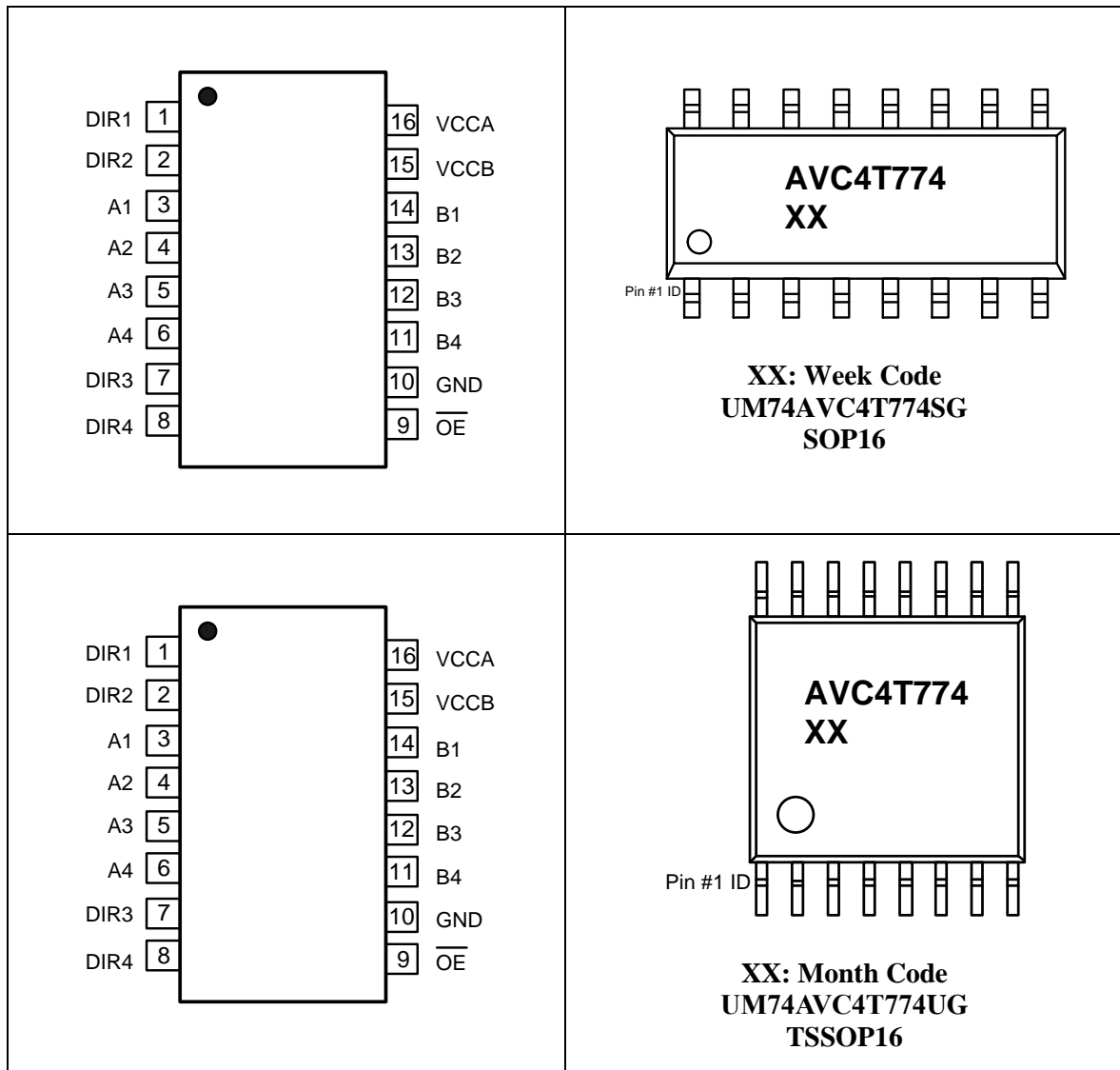

5 Pin Configuration and Function (continued)

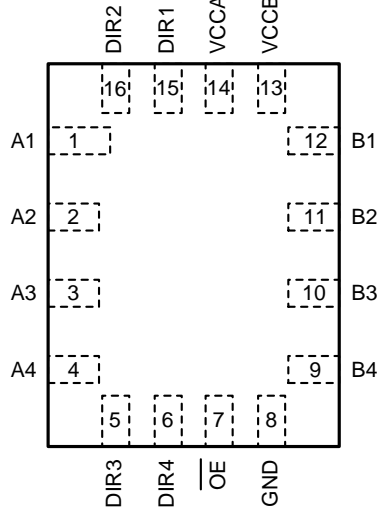
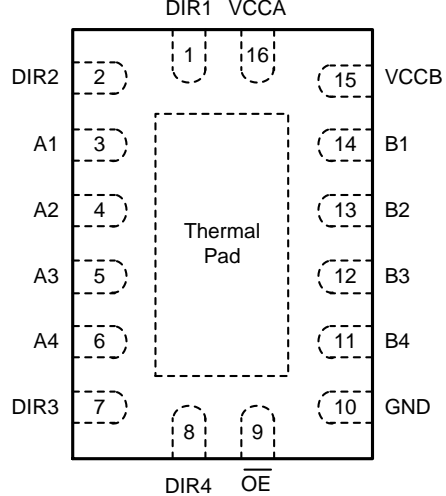
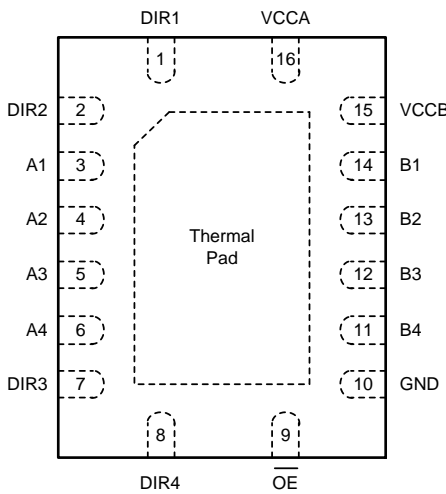
	<div style="border: 1px solid black; padding: 10px; text-align: center;"> <p>ABF \approx</p> <p>M: Month Code UM74AVC4T774QA QFN16 2.6×1.8</p> </div>
	<div style="border: 1px solid black; padding: 10px; text-align: center;"> <p>AQC \approx</p> <p>XX: Month Code UM74AVC4T774QB QFN16 2.5×3.5</p> </div>
	<div style="border: 1px solid black; padding: 10px; text-align: center;"> <p>AVC4T774 XX</p> <p>M: Month Code UM74AVC4T774QC QFN16 4.0×3.5</p> </div>

5 Pin Configuration and Function (continued)

Table 5-1. Pin Functions

Pin Name	Function
DIR1	Direction-control input referenced to V_{CCA} , controls signal flow for the first (A1/B1) I/O channels.
DIR2	Direction-control input referenced to V_{CCA} , controls signal flow for the second (A2/B2) I/O channels.
A1	Input/output A1. Referenced to V_{CCA} .
A2	Input/output A2. Referenced to V_{CCA} .
A3	Input/output A3. Referenced to V_{CCA} .
A4	Input/output A4. Referenced to V_{CCA} .
DIR3	Direction-control input referenced to V_{CCA} , controls signal flow for the third (A3/B3) I/O channels.
DIR4	Direction-control input referenced to V_{CCA} , controls signal flow for the fourth (A4/B4) I/O channels.
\overline{OE}	3-state output-mode enables. Pull high to place all outputs in 3-state mode. Referenced to V_{CCA} .
GND	Ground.
B4	Input/output B4. Referenced to V_{CCB} .
B3	Input/output B3. Referenced to V_{CCB} .
B2	Input/output B2. Referenced to V_{CCB} .
B1	Input/output B1. Referenced to V_{CCB} .
VCCB	B-port supply voltage. $1.0\text{ V} \leq V_{CCB} \leq 3.6\text{ V}$.
VCCA	A-port supply voltage. $1.0\text{ V} \leq V_{CCA} \leq 3.6\text{ V}$.

6 Specifications

6.1 Absolute Maximum Ratings (Note 1)

Symbol	Parameter		Value	Unit
V _{CCA}	Supply Voltage		-0.5 to +4.6	V
V _{CCB}	Supply Voltage		-0.5 to +4.6	V
V _I	Input Voltage (Note 2)	A ports	-0.5 to +4.6	V
		B ports	-0.5 to +4.6	
		Control inputs	-0.5 to +4.6	
V _O	Voltage applied to any output in the high-impedance or Power-Off State (Note 2)	A ports	-0.5 to +4.6	V
		B ports	-0.5 to +4.6	
V _O	Voltage Range Applied to Any Output in the High or Low State (Note 2, 3)	A ports	-0.5 to (V _{CCA} +0.5)	V
		B ports	-0.5 to (V _{CCB} +0.5)	
V _{ESD}	Human-body model (HBM), per ANSI/ESDA/JEDEC JS-001	A and B pins	±8	kV
		Other pins	±4	kV
	Charged-device model (CDM), per ANSI/ESDA/JEDEC JS-002	All pins	±2	kV
I _{IK}	Input clamp current	V _I <0	-50	mA
I _{OK}	Output clamp current	V _O <0	-50	mA
I _O	Continuous Output Current		±50	mA
	Continuous Current through V _{CCA} , V _{CCB} , or GND		±100	mA
T _J	Operating Junction Temperature		-40 to +150	°C
T _{STG}	Storage Temperature		-65 to +150	°C

Note 1: Stresses beyond those listed under "Absolute Maximum Ratings" may cause permanent damage to the device. These are stress ratings only, and functional operation of the device at these or any other conditions beyond those indicated under "Recommended Operating Conditions" is not implied. Exposure to absolute-maximum-rated conditions for extended periods may affect device reliability.

Note 2: The input and output negative-voltage ratings may be exceeded if the input and output current ratings are observed.

Note 3: The output positive-voltage rating may be exceeded up to 4.6 V maximum if the output current rating is observed.

6.2 Recommended Operating Conditions (Note 1, 2, 3)

Over recommended operating free-air temperature range (unless otherwise noted).

Symbol	Parameter		V _{CCI}	V _{CCO}	Min	Max	Unit
V _{CCA}	Supply voltage				1	3.6	V
V _{CCB}					1	3.6	
V _{IH}	High-level input voltage	Data inputs	1V		V _{CCI} ×0.7		V
			1.1 V to 1.95 V		V _{CCI} ×0.65		
			1.95 V to 2.7 V		1.6		
			2.7V to 3.6 V		2		
V _{IL}	Low-level input voltage	Data inputs	1V		V _{CCI} ×0.3		V
			1.1 V to 1.95 V		V _{CCI} ×0.35		
			1.95 V to 2.7 V		0.7		
			2.7V to 3.6 V		0.8		
V _{IH}	High-level input voltage	Control inputs (DIR, \overline{OE}) referenced to V _{CCA}	1V		V _{CCI} ×0.7		V
			1.1 V to 1.95 V		V _{CCI} ×0.65		
			1.95 V to 2.7 V		1.6		
			2.7V to 3.6 V		2		
V _{IL}	Low-level input voltage	Control inputs (DIR, \overline{OE}) referenced to V _{CCA}	1V		V _{CCI} ×0.3		V
			1.1 V to 1.95 V		V _{CCI} ×0.35		
			1.95 V to 2.7 V		0.7		
			2.7V to 3.6 V		0.8		
V _I	Input voltage			0	3.6	V	
V _O	Output voltage	Active state			0	V _{CCO}	V
		Three-State			0	3.6	
I _{OH}	High-level output current		1.1V to 1.3 V			-3	mA
			1.4 V to 1.6 V			-6	
			1.65 V to 1.95 V			-8	
			2.3 V to 2.7 V			-9	
			3 V to 3.6 V			-12	
I _{OL}	Low-level output current		1.1V to 1.3 V			3	mA
			1.4 V to 1.6 V			6	
			1.65 V to 1.95 V			8	
			2.3 V to 2.7 V			9	
			3 V to 3.6 V			12	
$\Delta t/\Delta V$	Input transition rise or fall rate				10	ns/V	
T _A	Operating free-air temperature			-40	125	°C	

Note 1: V_{CCI} is the V_{CC} associated with the input port.

Note 2: V_{CCO} is the V_{CC} associated with the output port.

Note 3: All unused or driven (floating) data inputs (I/Os) of the device must be held at logic High or Low (preferably V_{CCI} or GND) to ensure proper device operation and minimize power.

6.3 Package Thermal Impedance

Symbol	Parameter		Value	Unit
R _{θJA}	Junction-to-ambient thermal resistance	SOP16	65.5	°C/W
		TSSOP16	123.8	
		QFN16 2.6×1.8	139.2	
		QFN16 2.5×3.5	79.1	
		QFN16 4.0×3.5	37.7	
R _{θJC(TOP)}	Junction-to-case (top) thermal resistance	SOP16	26.9	°C/W
		TSSOP16	58.3	
		QFN16 2.6×1.8	64.9	
		QFN16 2.5×3.5	77.5	
		QFN16 4.0×3.5	56.1	
R _{θJB}	Junction-to-board thermal resistance	SOP16	23	°C/W
		TSSOP16	81.7	
		QFN16 2.6×1.8	67.7	
		QFN16 2.5×3.5	49	
		QFN16 4.0×3.5	15.9	

6.4 Electrical Characteristics (Note 1, 2)

Over recommended operating free-air temperature range (unless otherwise noted).

Parameter		Test Conditions	V _{CCA}	V _{CCB}	Min	Typ	Max	Unit	
V _{OH}		I _{OH} =-100μA I _{OH} =-3mA I _{OH} =-6mA I _{OH} =-8mA I _{OH} =-9mA I _{OH} =-12mA	V _I =V _{IH}	1V to 3.6V	1V to 3.6V	V _{CCO} -0.2			V
				1.1V	1.1V	0.85	0.98		
				1.4V	1.4V	1			
				1.65V	1.65V	1.2			
				2.3V	2.3V	1.8			
				3V	3V	2.4			
V _{OL}		I _{OL} =100μA I _{OL} =3mA I _{OL} =6mA I _{OL} =8mA I _{OL} =9mA I _{OL} =12mA	V _I =V _{IL}	1V to 3.6V	1V to 3.6V			0.2	V
				1.1V	1.1V		0.1	0.25	
				1.4V	1.4V			0.35	
				1.65V	1.65V			0.45	
				2.3V	2.3V			0.55	
				3V	3V			0.7	
I _I	Control inputs	V _I = V _{CCA} or GND	1V to 3.6V	1V to 3.6V	-1	0.1	1	μA	
I _{OZ}	A or B Port	V _O = V _{CCO} or GND, V _I = V _{CCI} or GND, OE = V _{IH}	3.6V	3.6V	-5	0.1	5	μA	
I _{OFF}	A or B Port	V _I or V _O = 0 to 3.6V	0V	0V to 3.6V	-5	0.1	5	μA	
			0V to 3.6V	0V	-5	0.1	5		
I _{CCA}		V _I =V _{CCI} or GND I _O =0	1V to 3.6V	1V to 3.6V			8	μA	
			0V	3.6V	-2				
			3.6V	0V			8		
I _{CCB}		V _I =V _{CCI} or GND I _O =0	1V to 3.6V	1V to 3.6V			8	μA	
			0V	3.6V			8		
			3.6V	0V	-2				
I _{CCA} +I _{CCB}		V _I =V _{CCI} or GND I _O =0	1V to 3.6V	1V to 3.6V			16	μA	
C _I	Control inputs	V _I = 3.3V or GND	3.3V	3.3V			7.5	pF	
C _{IO}	A or B Port	V _O = 3.3V or GND	3.3V	3.3V			8.5	pF	

Note 1: V_{CCI} is the V_{CC} associated with the input port.

Note 2: V_{CCO} is the V_{CC} associated with the output port.

6.5 Switching Characteristics

Over recommended operating free-air temperature range, $V_{CCA} = 1V$.

Parameter	From (Input)	To (Output)	V_{CCB}	Min	Typ	Max	Unit
t_{PLH}, t_{PHL}	A	B	$V_{CCB}=1V$	0.5		30	ns
			$V_{CCB}=1.2V \pm 0.1V$	0.5		20	
			$V_{CCB}=1.5V \pm 0.1V$	0.5		17	
			$V_{CCB}=1.8V \pm 0.15V$	0.5		15	
			$V_{CCB}=2.5V \pm 0.2V$	0.5		15	
			$V_{CCB}=3.3V \pm 0.3V$	0.5		17	
t_{PLH}, t_{PHL}	B	A	$V_{CCB}=1V$	0.5		30	ns
			$V_{CCB}=1.2V \pm 0.1V$	0.5		20	
			$V_{CCB}=1.5V \pm 0.1V$	0.5		17	
			$V_{CCB}=1.8V \pm 0.15V$	0.5		15	
			$V_{CCB}=2.5V \pm 0.2V$	0.5		17	
			$V_{CCB}=3.3V \pm 0.3V$	0.5		17	
t_{PZH}, t_{PZL}	\overline{OE}	A	$V_{CCB}=1V$	0.5		40	ns
			$V_{CCB}=1.2V \pm 0.1V$	0.5		35	
			$V_{CCB}=1.5V \pm 0.1V$	0.5		35	
			$V_{CCB}=1.8V \pm 0.15V$	0.5		35	
			$V_{CCB}=2.5V \pm 0.2V$	0.5		35	
			$V_{CCB}=3.3V \pm 0.3V$	0.5		35	
t_{PZH}, t_{PZL}	\overline{OE}	B	$V_{CCB}=1V$	0.5		40	ns
			$V_{CCB}=1.2V \pm 0.1V$	0.5		35	
			$V_{CCB}=1.5V \pm 0.1V$	0.5		35	
			$V_{CCB}=1.8V \pm 0.15V$	0.5		35	
			$V_{CCB}=2.5V \pm 0.2V$	0.5		35	
			$V_{CCB}=3.3V \pm 0.3V$	0.5		35	
t_{PHZ}, t_{PLZ}	\overline{OE}	A	$V_{CCB}=1V$	0.5		35	ns
			$V_{CCB}=1.2V \pm 0.1V$	0.5		35	
			$V_{CCB}=1.5V \pm 0.1V$	0.5		35	
			$V_{CCB}=1.8V \pm 0.15V$	0.5		35	
			$V_{CCB}=2.5V \pm 0.2V$	0.5		35	
			$V_{CCB}=3.3V \pm 0.3V$	0.5		35	
t_{PHZ}, t_{PLZ}	\overline{OE}	B	$V_{CCB}=1V$	0.5		40	ns
			$V_{CCB}=1.2V \pm 0.1V$	0.5		35	
			$V_{CCB}=1.5V \pm 0.1V$	0.5		35	
			$V_{CCB}=1.8V \pm 0.15V$	0.5		35	
			$V_{CCB}=2.5V \pm 0.2V$	0.5		35	
			$V_{CCB}=3.3V \pm 0.3V$	0.5		35	

6.5 Switching Characteristics (continued)

Over recommended operating free-air temperature range, $V_{CCA} = 1.2V \pm 0.1V$.

Parameter	From (Input)	To (Output)	V_{CCB}	Min	Typ	Max	Unit
t_{PLH}, t_{PHL}	A	B	$V_{CCB}=1V$	0.5		23	ns
			$V_{CCB}=1.2V \pm 0.1V$	0.5		15	
			$V_{CCB}=1.5V \pm 0.1V$	0.5		10	
			$V_{CCB}=1.8V \pm 0.15V$	0.5		9	
			$V_{CCB}=2.5V \pm 0.2V$	0.5		7	
			$V_{CCB}=3.3V \pm 0.3V$	0.5		7.5	
t_{PLH}, t_{PHL}	B	A	$V_{CCB}=1V$	0.5		23	ns
			$V_{CCB}=1.2V \pm 0.1V$	0.5		15	
			$V_{CCB}=1.5V \pm 0.1V$	0.5		13	
			$V_{CCB}=1.8V \pm 0.15V$	0.5		11	
			$V_{CCB}=2.5V \pm 0.2V$	0.5		8	
			$V_{CCB}=3.3V \pm 0.3V$	0.5		7	
t_{PZH}, t_{PZL}	\overline{OE}	A	$V_{CCB}=1V$	0.5		30	ns
			$V_{CCB}=1.2V \pm 0.1V$	0.5		30	
			$V_{CCB}=1.5V \pm 0.1V$	0.5		30	
			$V_{CCB}=1.8V \pm 0.15V$	0.5		30	
			$V_{CCB}=2.5V \pm 0.2V$	0.5		30	
			$V_{CCB}=3.3V \pm 0.3V$	0.5		30	
t_{PZH}, t_{PZL}	\overline{OE}	B	$V_{CCB}=1V$	0.5		30	ns
			$V_{CCB}=1.2V \pm 0.1V$	0.5		25	
			$V_{CCB}=1.5V \pm 0.1V$	0.5		25	
			$V_{CCB}=1.8V \pm 0.15V$	0.5		25	
			$V_{CCB}=2.5V \pm 0.2V$	0.5		25	
			$V_{CCB}=3.3V \pm 0.3V$	0.5		25	
t_{PHZ}, t_{PLZ}	\overline{OE}	A	$V_{CCB}=1V$	0.5		35	ns
			$V_{CCB}=1.2V \pm 0.1V$	0.5		30	
			$V_{CCB}=1.5V \pm 0.1V$	0.5		30	
			$V_{CCB}=1.8V \pm 0.15V$	0.5		30	
			$V_{CCB}=2.5V \pm 0.2V$	0.5		30	
			$V_{CCB}=3.3V \pm 0.3V$	0.5		30	
t_{PHZ}, t_{PLZ}	\overline{OE}	B	$V_{CCB}=1V$	0.5		35	ns
			$V_{CCB}=1.2V \pm 0.1V$	0.5		30	
			$V_{CCB}=1.5V \pm 0.1V$	0.5		30	
			$V_{CCB}=1.8V \pm 0.15V$	0.5		30	
			$V_{CCB}=2.5V \pm 0.2V$	0.5		30	
			$V_{CCB}=3.3V \pm 0.3V$	0.5		30	

6.5 Switching Characteristics (continued)

Over recommended operating free-air temperature range, $V_{CCA} = 1.5V \pm 0.1V$.

Parameter	From (Input)	To (Output)	V_{CCB}	Min	Typ	Max	Unit
t_{PLH}, t_{PHL}	A	B	$V_{CCB}=1V$	0.5		18	ns
			$V_{CCB}=1.2V \pm 0.1V$	0.5		13	
			$V_{CCB}=1.5V \pm 0.1V$	0.5		9	
			$V_{CCB}=1.8V \pm 0.15V$	0.5		7	
			$V_{CCB}=2.5V \pm 0.2V$	0.5		6	
			$V_{CCB}=3.3V \pm 0.3V$	0.5		5.5	
t_{PLH}, t_{PHL}	B	A	$V_{CCB}=1V$	0.5		17	ns
			$V_{CCB}=1.2V \pm 0.1V$	0.5		11	
			$V_{CCB}=1.5V \pm 0.1V$	0.5		9	
			$V_{CCB}=1.8V \pm 0.15V$	0.5		7.5	
			$V_{CCB}=2.5V \pm 0.2V$	0.5		6	
			$V_{CCB}=3.3V \pm 0.3V$	0.5		5	
t_{PZH}, t_{PZL}	\overline{OE}	A	$V_{CCB}=1V$	0.5		25	ns
			$V_{CCB}=1.2V \pm 0.1V$	0.5		23	
			$V_{CCB}=1.5V \pm 0.1V$	0.5		23	
			$V_{CCB}=1.8V \pm 0.15V$	0.5		23	
			$V_{CCB}=2.5V \pm 0.2V$	0.5		23	
			$V_{CCB}=3.3V \pm 0.3V$	0.5		23	
t_{PZH}, t_{PZL}	\overline{OE}	B	$V_{CCB}=1V$	0.5		27	ns
			$V_{CCB}=1.2V \pm 0.1V$	0.5		24	
			$V_{CCB}=1.5V \pm 0.1V$	0.5		20	
			$V_{CCB}=1.8V \pm 0.15V$	0.5		20	
			$V_{CCB}=2.5V \pm 0.2V$	0.5		20	
			$V_{CCB}=3.3V \pm 0.3V$	0.5		20	
t_{PHZ}, t_{PLZ}	\overline{OE}	A	$V_{CCB}=1V$	0.5		34	ns
			$V_{CCB}=1.2V \pm 0.1V$	0.5		34	
			$V_{CCB}=1.5V \pm 0.1V$	0.5		34	
			$V_{CCB}=1.8V \pm 0.15V$	0.5		34	
			$V_{CCB}=2.5V \pm 0.2V$	0.5		34	
			$V_{CCB}=3.3V \pm 0.3V$	0.5		34	
t_{PHZ}, t_{PLZ}	\overline{OE}	B	$V_{CCB}=1V$	0.5		45	ns
			$V_{CCB}=1.2V \pm 0.1V$	0.5		40	
			$V_{CCB}=1.5V \pm 0.1V$	0.5		35	
			$V_{CCB}=1.8V \pm 0.15V$	0.5		31	
			$V_{CCB}=2.5V \pm 0.2V$	0.5		28	
			$V_{CCB}=3.3V \pm 0.3V$	0.5		25	

6.5 Switching Characteristics (continued)

Over recommended operating free-air temperature range, $V_{CCA} = 1.8V \pm 0.15V$.

Parameter	From (Input)	To (Output)	V_{CCB}	Min	Typ	Max	Unit
t_{PLH}, t_{PHL}	A	B	$V_{CCB}=1V$	0.5		16	ns
			$V_{CCB}=1.2V \pm 0.1V$	0.5		11	
			$V_{CCB}=1.5V \pm 0.1V$	0.5		8	
			$V_{CCB}=1.8V \pm 0.15V$	0.5		7	
			$V_{CCB}=2.5V \pm 0.2V$	0.5		6	
			$V_{CCB}=3.3V \pm 0.3V$	0.5		5	
t_{PLH}, t_{PHL}	B	A	$V_{CCB}=1V$	0.5		16	ns
			$V_{CCB}=1.2V \pm 0.1V$	0.5		10	
			$V_{CCB}=1.5V \pm 0.1V$	0.5		7	
			$V_{CCB}=1.8V \pm 0.15V$	0.5		7	
			$V_{CCB}=2.5V \pm 0.2V$	0.5		5	
			$V_{CCB}=3.3V \pm 0.3V$	0.5		4	
t_{PZH}, t_{PZL}	\overline{OE}	A	$V_{CCB}=1V$	0.5		23	ns
			$V_{CCB}=1.2V \pm 0.1V$	0.5		20	
			$V_{CCB}=1.5V \pm 0.1V$	0.5		17	
			$V_{CCB}=1.8V \pm 0.15V$	0.5		17	
			$V_{CCB}=2.5V \pm 0.2V$	0.5		17	
			$V_{CCB}=3.3V \pm 0.3V$	0.5		17	
t_{PZH}, t_{PZL}	\overline{OE}	B	$V_{CCB}=1V$	0.5		23	ns
			$V_{CCB}=1.2V \pm 0.1V$	0.5		23	
			$V_{CCB}=1.5V \pm 0.1V$	0.5		17	
			$V_{CCB}=1.8V \pm 0.15V$	0.5		15	
			$V_{CCB}=2.5V \pm 0.2V$	0.5		15	
			$V_{CCB}=3.3V \pm 0.3V$	0.5		15	
t_{PHZ}, t_{PLZ}	\overline{OE}	A	$V_{CCB}=1V$	0.5		30	ns
			$V_{CCB}=1.2V \pm 0.1V$	0.5		30	
			$V_{CCB}=1.5V \pm 0.1V$	0.5		30	
			$V_{CCB}=1.8V \pm 0.15V$	0.5		30	
			$V_{CCB}=2.5V \pm 0.2V$	0.5		30	
			$V_{CCB}=3.3V \pm 0.3V$	0.5		30	
t_{PHZ}, t_{PLZ}	\overline{OE}	B	$V_{CCB}=1V$	0.5		30	ns
			$V_{CCB}=1.2V \pm 0.1V$	0.5		30	
			$V_{CCB}=1.5V \pm 0.1V$	0.5		30	
			$V_{CCB}=1.8V \pm 0.15V$	0.5		30	
			$V_{CCB}=2.5V \pm 0.2V$	0.5		30	
			$V_{CCB}=3.3V \pm 0.3V$	0.5		30	

6.5 Switching Characteristics (continued)

Over recommended operating free-air temperature range, $V_{CCA} = 2.5V \pm 0.2V$.

Parameter	From (Input)	To (Output)	V_{CCB}	Min	Typ	Max	Unit
t_{PLH}, t_{PHL}	A	B	$V_{CCB}=1V$	0.5		15	ns
			$V_{CCB}=1.2V \pm 0.1V$	0.5		8	
			$V_{CCB}=1.5V \pm 0.1V$	0.5		6	
			$V_{CCB}=1.8V \pm 0.15V$	0.5		5.5	
			$V_{CCB}=2.5V \pm 0.2V$	0.5		5	
			$V_{CCB}=3.3V \pm 0.3V$	0.5		4	
t_{PLH}, t_{PHL}	B	A	$V_{CCB}=1V$	0.5		15	ns
			$V_{CCB}=1.2V \pm 0.1V$	0.5		7.5	
			$V_{CCB}=1.5V \pm 0.1V$	0.5		6	
			$V_{CCB}=1.8V \pm 0.15V$	0.5		5.5	
			$V_{CCB}=2.5V \pm 0.2V$	0.5		5	
			$V_{CCB}=3.3V \pm 0.3V$	0.5		4	
t_{PZH}, t_{PZL}	\overline{OE}	A	$V_{CCB}=1V$	0.5		25	ns
			$V_{CCB}=1.2V \pm 0.1V$	0.5		20	
			$V_{CCB}=1.5V \pm 0.1V$	0.5		15	
			$V_{CCB}=1.8V \pm 0.15V$	0.5		15	
			$V_{CCB}=2.5V \pm 0.2V$	0.5		15	
			$V_{CCB}=3.3V \pm 0.3V$	0.5		15	
t_{PZH}, t_{PZL}	\overline{OE}	B	$V_{CCB}=1V$	0.5		21	ns
			$V_{CCB}=1.2V \pm 0.1V$	0.5		18	
			$V_{CCB}=1.5V \pm 0.1V$	0.5		15	
			$V_{CCB}=1.8V \pm 0.15V$	0.5		15	
			$V_{CCB}=2.5V \pm 0.2V$	0.5		15	
			$V_{CCB}=3.3V \pm 0.3V$	0.5		15	
t_{PHZ}, t_{PLZ}	\overline{OE}	A	$V_{CCB}=1V$	0.5		25	ns
			$V_{CCB}=1.2V \pm 0.1V$	0.5		25	
			$V_{CCB}=1.5V \pm 0.1V$	0.5		25	
			$V_{CCB}=1.8V \pm 0.15V$	0.5		25	
			$V_{CCB}=2.5V \pm 0.2V$	0.5		25	
			$V_{CCB}=3.3V \pm 0.3V$	0.5		25	
t_{PHZ}, t_{PLZ}	\overline{OE}	B	$V_{CCB}=1V$	0.5		35	ns
			$V_{CCB}=1.2V \pm 0.1V$	0.5		32	
			$V_{CCB}=1.5V \pm 0.1V$	0.5		30	
			$V_{CCB}=1.8V \pm 0.15V$	0.5		28	
			$V_{CCB}=2.5V \pm 0.2V$	0.5		25	
			$V_{CCB}=3.3V \pm 0.3V$	0.5		23	

6.5 Switching Characteristics (continued)

Over recommended operating free-air temperature range, $V_{CCA} = 3.3V \pm 0.3V$.

Parameter	From (Input)	To (Output)	V_{CCB}	Min	Typ	Max	Unit
t_{PLH}, t_{PHL}	A	B	$V_{CCB}=1V$	0.5		16	ns
			$V_{CCB}=1.2V \pm 0.1V$	0.5		7	
			$V_{CCB}=1.5V \pm 0.1V$	0.5		5	
			$V_{CCB}=1.8V \pm 0.15V$	0.5		4	
			$V_{CCB}=2.5V \pm 0.2V$	0.5		4	
			$V_{CCB}=3.3V \pm 0.3V$	0.5		4	
t_{PLH}, t_{PHL}	B	A	$V_{CCB}=1V$	0.5		16	ns
			$V_{CCB}=1.2V \pm 0.1V$	0.5		7	
			$V_{CCB}=1.5V \pm 0.1V$	0.5		6	
			$V_{CCB}=1.8V \pm 0.15V$	0.5		5	
			$V_{CCB}=2.5V \pm 0.2V$	0.5		4	
			$V_{CCB}=3.3V \pm 0.3V$	0.5		4	
t_{PZH}, t_{PZL}	\overline{OE}	A	$V_{CCB}=1V$	0.5		25	ns
			$V_{CCB}=1.2V \pm 0.1V$	0.5		20	
			$V_{CCB}=1.5V \pm 0.1V$	0.5		15	
			$V_{CCB}=1.8V \pm 0.15V$	0.5		15	
			$V_{CCB}=2.5V \pm 0.2V$	0.5		15	
			$V_{CCB}=3.3V \pm 0.3V$	0.5		15	
t_{PZH}, t_{PZL}	\overline{OE}	B	$V_{CCB}=1V$	0.5		25	ns
			$V_{CCB}=1.2V \pm 0.1V$	0.5		20	
			$V_{CCB}=1.5V \pm 0.1V$	0.5		15	
			$V_{CCB}=1.8V \pm 0.15V$	0.5		15	
			$V_{CCB}=2.5V \pm 0.2V$	0.5		15	
			$V_{CCB}=3.3V \pm 0.3V$	0.5		15	
t_{PHZ}, t_{PLZ}	\overline{OE}	A	$V_{CCB}=1V$	0.5		22	ns
			$V_{CCB}=1.2V \pm 0.1V$	0.5		22	
			$V_{CCB}=1.5V \pm 0.1V$	0.5		22	
			$V_{CCB}=1.8V \pm 0.15V$	0.5		22	
			$V_{CCB}=2.5V \pm 0.2V$	0.5		22	
			$V_{CCB}=3.3V \pm 0.3V$	0.5		22	
t_{PHZ}, t_{PLZ}	\overline{OE}	B	$V_{CCB}=1V$	0.5		36	ns
			$V_{CCB}=1.2V \pm 0.1V$	0.5		33	
			$V_{CCB}=1.5V \pm 0.1V$	0.5		30	
			$V_{CCB}=1.8V \pm 0.15V$	0.5		27	
			$V_{CCB}=2.5V \pm 0.2V$	0.5		25	
			$V_{CCB}=3.3V \pm 0.3V$	0.5		23	

6.6 Operating Characteristics (Note 1)

$T_A=25^{\circ}\text{C}$.

Parameter			Test Conditions	$V_{CCA} =$ $V_{CCB} =$ 1V	$V_{CCA} =$ $V_{CCB} =$ 1.2V	$V_{CCA} =$ $V_{CCB} =$ 1.5V	$V_{CCA} =$ $V_{CCB} =$ 1.8V	$V_{CCA} =$ $V_{CCB} =$ 2.5V	$V_{CCA} =$ $V_{CCB} =$ 3.3V	Unit
				Typ	Typ	Typ	Typ	Typ	Typ	
C_{PDA}	A to B	Outputs enabled	$C_L = 0,$ $f=10\text{MHz},$ $t_r = t_f = 1\text{ns}$	2	2.2	2.3	2.5	2.7	3.5	pF
		Outputs disabled		1	1	1	1	1	1	
	B to A	Outputs enabled		12	12	12	12	13	13.5	
		Outputs disabled		1	1	1	1	1	1	
C_{PDB}	A to B	Outputs enabled		12	12	12	12	13	13.5	
		Outputs disabled		1	1	1	1	1	1	
	B to A	Outputs enabled		2	2.2	2.3	2.5	2.7	3.5	
		Outputs disabled		1	1	1	1	1	1	

Note 1: C_{PDA} and C_{PDB} are power dissipation capacitance per transceiver.

7 Parameter Measurement Information

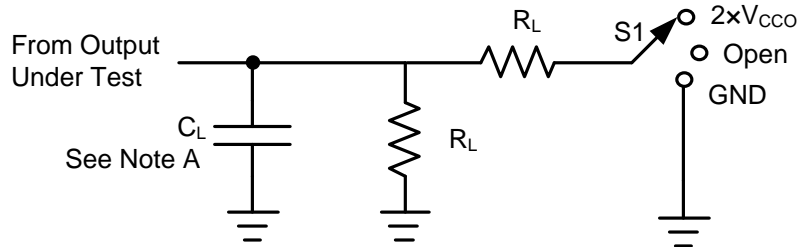

Figure 7-1. Load Circuit

Parameter	V _{CCO}	C _L	R _L	S1	V _{TP}
t _{PD}	1V to 3.6V	15pF	2kΩ	Open	N/A
t _{PLZ} , t _{PZL}	1V to 1.6V	15pF	2kΩ	2 × V _{CCO}	0.1V
	1.65V to 2.7V	15pF	2kΩ	2 × V _{CCO}	0.15V
	3V to 3.6V	15pF	2kΩ	2 × V _{CCO}	0.3V
t _{PHZ} , t _{PZH}	1V to 1.6V	15pF	2kΩ	GND	0.1V
	1.65V to 2.7V	15pF	2kΩ	GND	0.15V
	3V to 3.6V	15pF	2kΩ	GND	0.3V

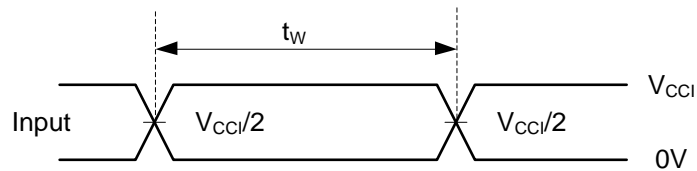

Figure 7-2. Voltage Waveforms Pulse Duration

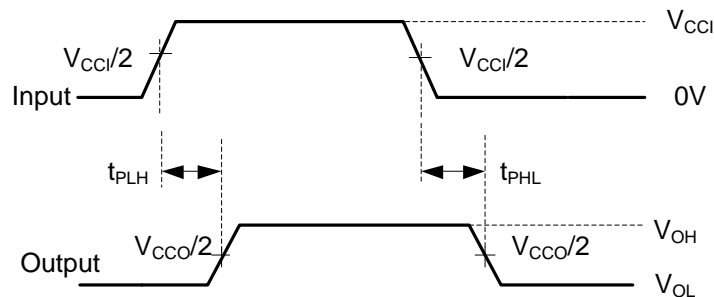

Figure 7-3. Voltage Waveforms Propagation Delay Times

7 Parameter Measurement Information (continued)

Figure 7-4. Voltage Waveforms Enable and Disable Times

Notes:

- A. C_L includes probe and jig capacitance.
- B. Waveform 1 is for an output with internal conditions such that the output is low, except when disabled by the output control. Waveform 2 is for an output with internal conditions such that the output is high, except when disabled by the output control.
- C. All input pulses are supplied by generators having the following characteristics: $PRR \leq 10$ MHz, $Z_O = 50\Omega$, $dv/dt \geq 1V/ns$.
- D. The outputs are measured one at a time, with one transition per measurement.
- E. t_{PLZ} and t_{PHZ} are the same as t_{DIS} .
- F. t_{PZL} and t_{PZH} are the same as t_{EN} .
- G. t_{PLH} and t_{PHL} are the same as t_{PD} .
- H. V_{CCI} is the V_{CC} associated with the input port.
- I. V_{CCO} is the V_{CC} associated with the output port.

8 Detailed Description

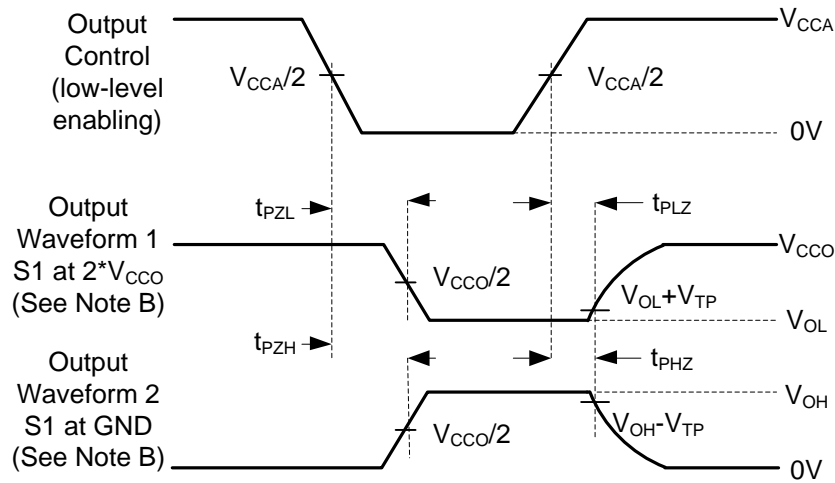
8.1 Overview

The UM74AVC4T774 is a 4-bit, dual-supply, noninverting, bi-directional voltage level translation. Pins An and control pins (DIR1, DIR2, DIR3, DIR4 and \overline{OE}) are support by V_{CCA} and pins Bn are support by V_{CCB} . The A ports and B ports are able to accept I/O voltages ranging from 1.0 V to 3.6 V. A high on DIR allows data transmission from An to Bn and a low on DIR allows data transmission from B to A when \overline{OE} is set to low. When \overline{OE} is set to high, both An and Bn are in the high-impedance state.

8.2 Functional Block Diagram

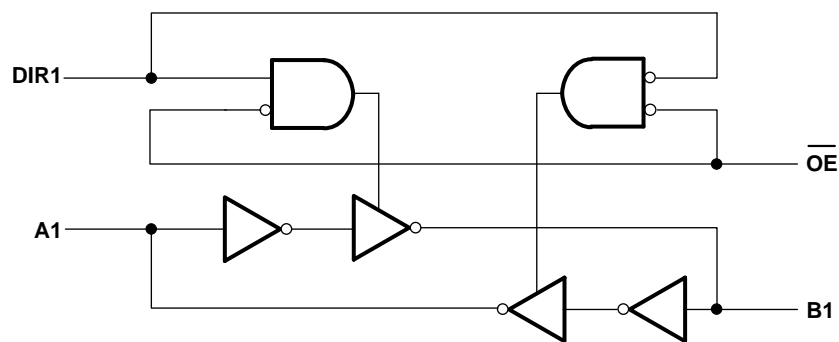

Figure 8-1. UM74AVC4T774 Block Diagram

9 Feature Description

9.1 Fully Configurable Dual-Rail Design

The fully configurable dual-rail design allows each port to operate over the full 1.0 V to 3.6 V power-supply range. Both V_{CCA} and V_{CCB} can be supplied at any voltage between 1.0 V and 3.6 V making the device an excellent choice for translating between any of the low voltage nodes (1.0V, 1.2 V, 1.8 V, 2.5 V and 3.3 V).

9.2 I_{OFF} Supports Partial-Power-Down Mode Operation

I_{OFF} prevents backflow current by disabling I/O output circuits when device is in partial power-down mode. The inputs and outputs for this device enter a high-impedance state when the device is powered down, inhibiting current backflow into the device. The maximum leakage into or out of any input or output pin on the device is specified by I_{OFF} in the Electrical Characteristics.

9.3 V_{CC} Isolation

The I/Os of both ports will enter a high-impedance state when one of the supplies are at GND, while the other supply is still connected to the device (I_{OZ} shown in Electrical Characteristics).

9.4 Device Functional Modes

All control inputs are referenced to V_{CCA} and must be driven to a valid Logic High or Logic Low (that is, not floating) to assure proper device operation and to prevent excessive power consumption. Table 9-1 summarizes the possible modes of device operation based on the configuration of the control inputs.

Table 9-1. Function Table

Control Inputs		Output Circuits		Operation
\overline{OE}	DIR	A port	B port	
L	L	Enabled	Hi-Z	B data to A data
L	H	Hi-Z	Enabled	A data to B data
H	X	Hi-Z	Hi-Z	Isolation

10 Application Information

10.1 Application Information

The UM74AVC4T774 device can be used in level-translation applications for interfacing devices or systems operating at different interface voltages with one another. The device is designed for use in applications where a push-pull driver is connected to the data I/Os. The max data rate can be up to 400Mbps when the device translate signal is from 1.8V to 3.3V.

10.2 Typical Application

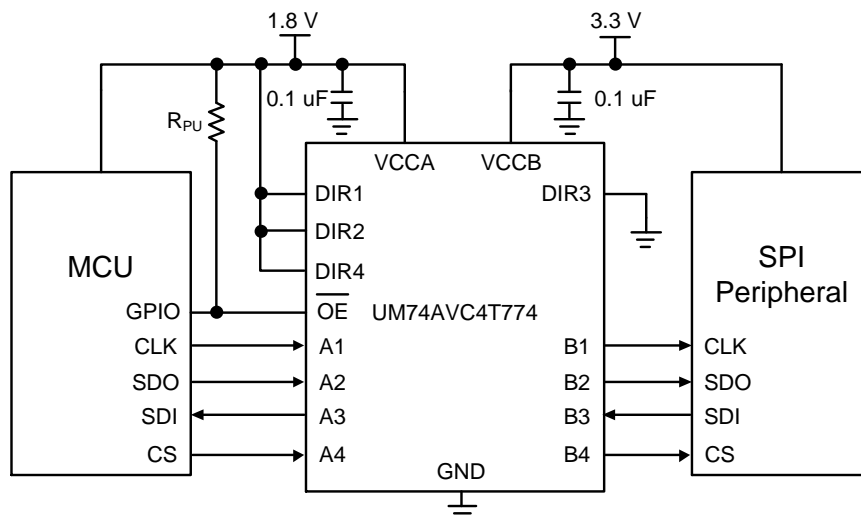
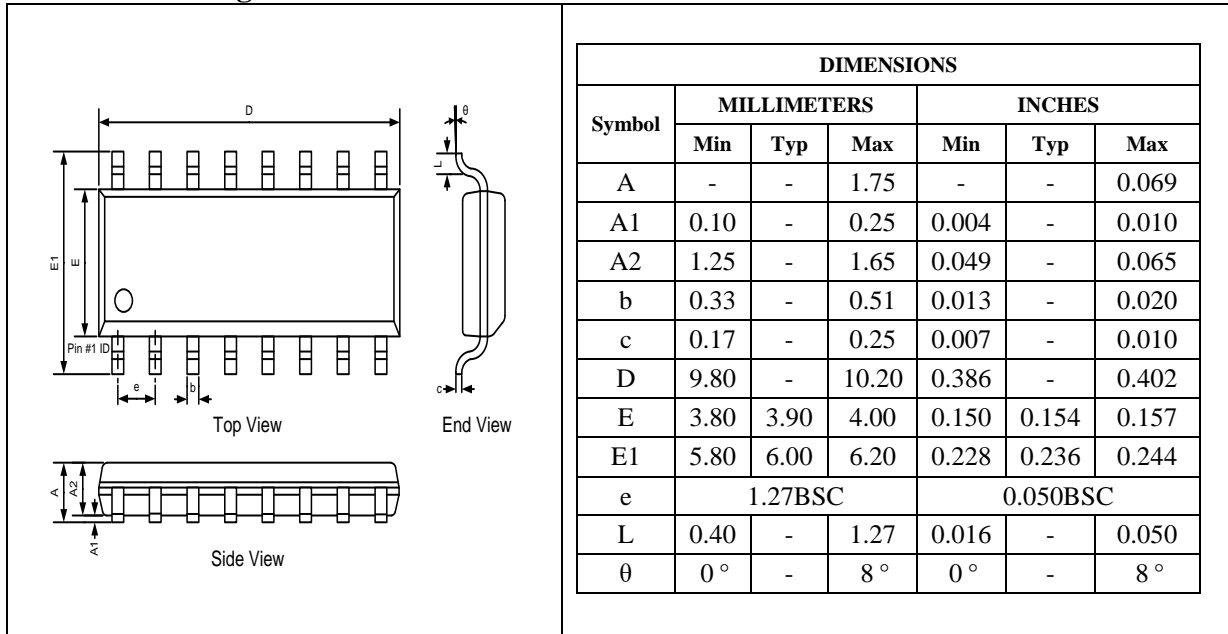

Figure 10-1. UM74AVC4T774 Typical Application

Package Information

SOP16

Outline Drawing



Land Pattern

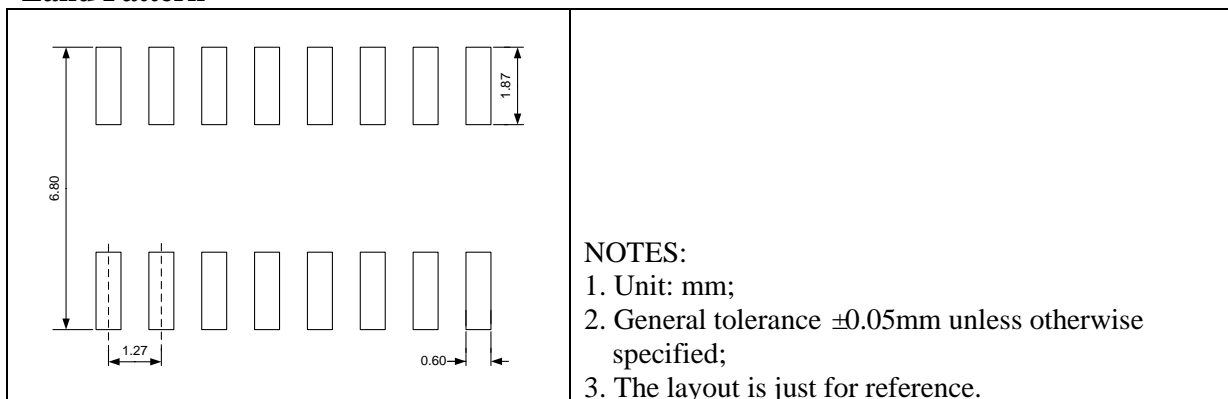

TSSOP16

Outline Drawing

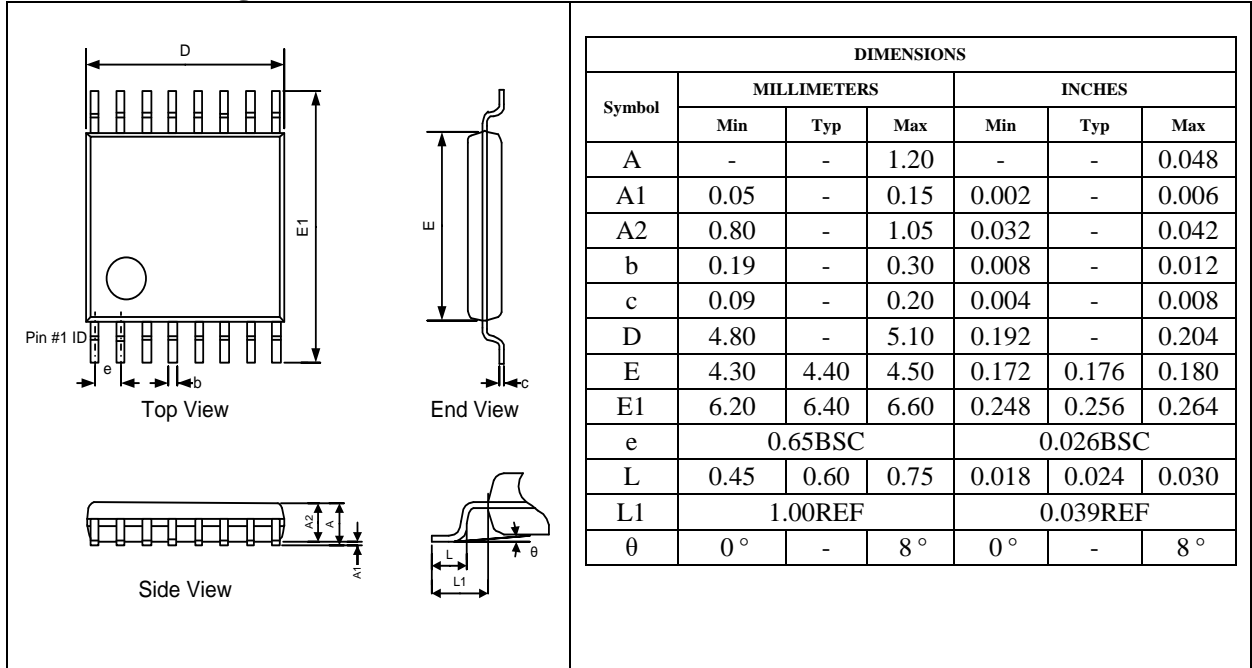

Land Pattern

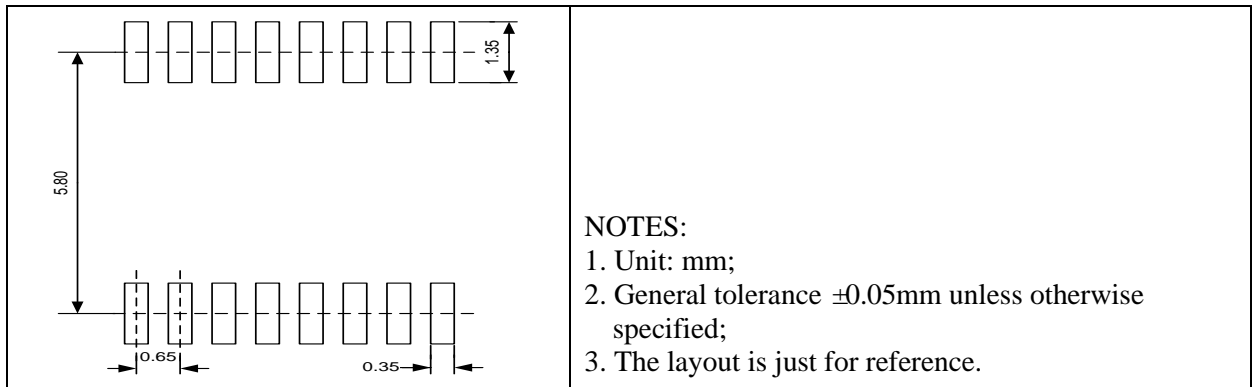

QFN16 2.6×1.8

Outline Drawing

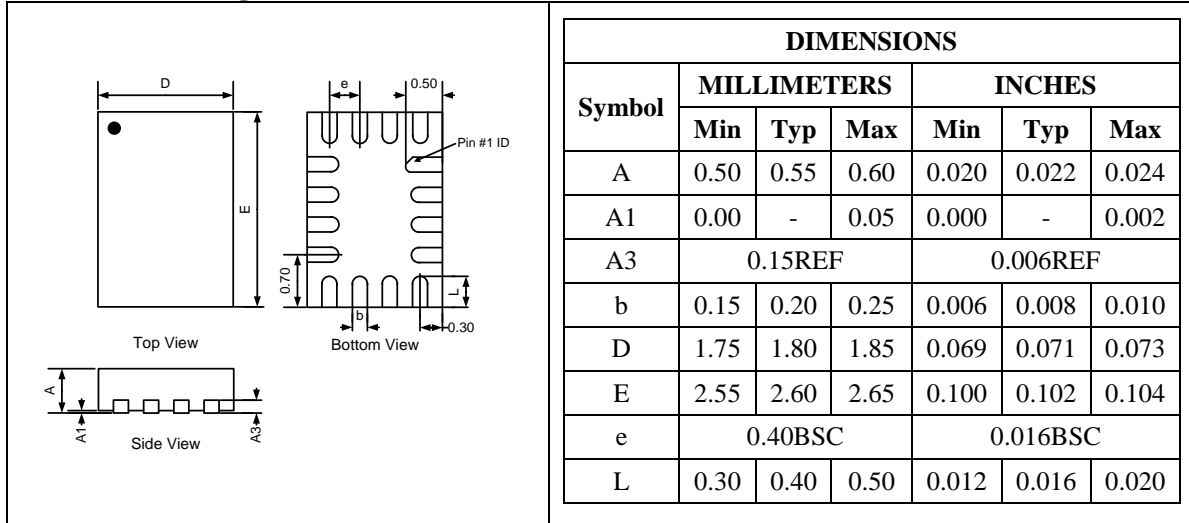

Land Pattern

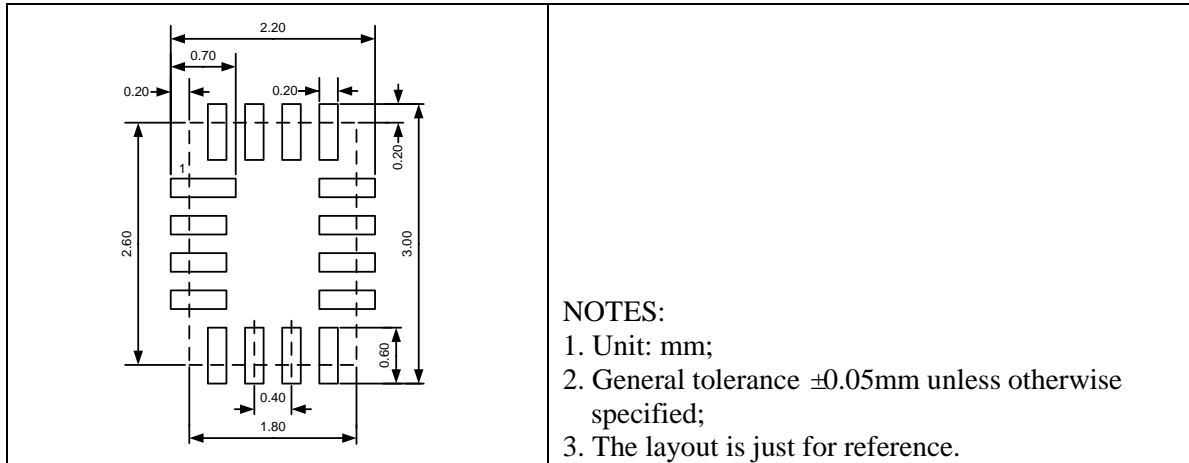

QFN16 4.0×3.5

Outline Drawing

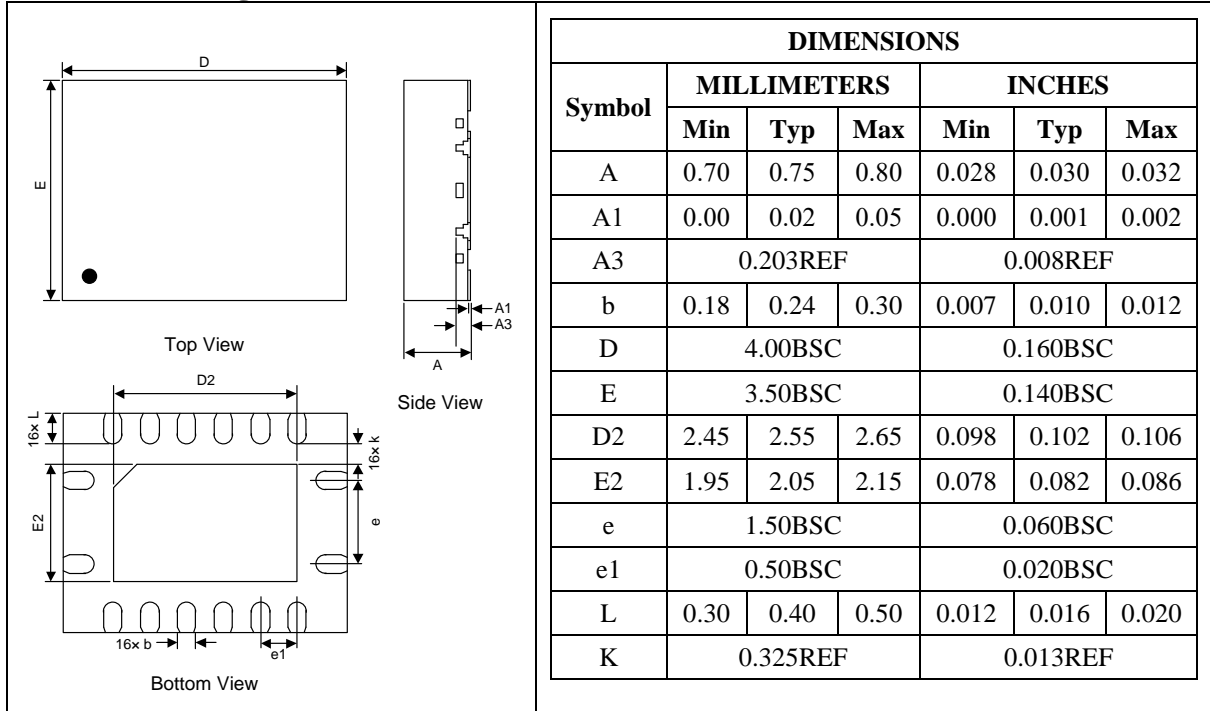

Land Pattern

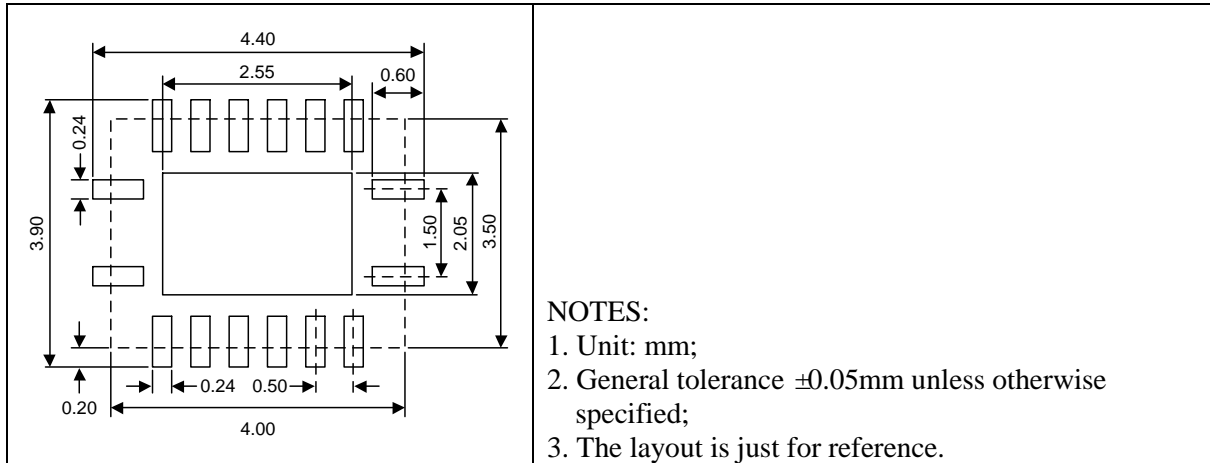

Packing Information

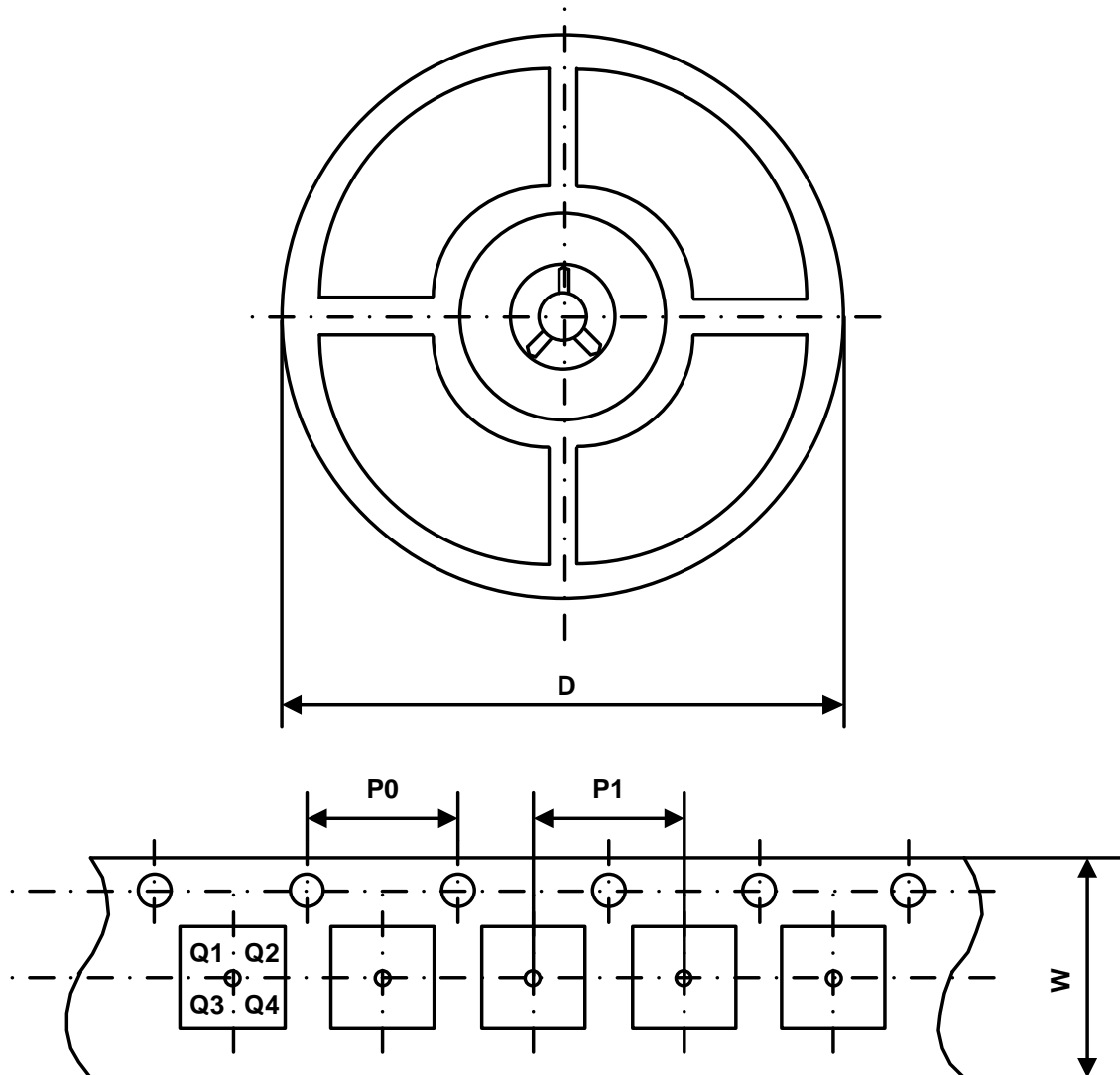

Part Number	Package Type	Carrier Width (W)	Pitch (P0)	Pitch (P1)	Reel Size (D)	PIN 1 Quadrant
UM74AVC4T774SG	SOP16	16 mm	4 mm	8 mm	330 mm	Q1
UM74AVC4T774UG	TSSOP16	16 mm	4 mm	8 mm	330 mm	Q1
UM74AVC4T774QA	QFN16 2.6×1.8	8 mm	4 mm	4 mm	180 mm	Q1
UM74AVC4T774QB	QFN16 2.5×3.5	12 mm	4 mm	8 mm	330 mm	Q1
UM74AVC4T774QC	QFN16 4.0×3.5	12 mm	4 mm	8 mm	330 mm	Q1

GREEN COMPLIANCE

Union Semiconductor is committed to environmental excellence in all aspects of its operations including meeting or exceeding regulatory requirements with respect to the use of hazardous substances. Numerous successful programs have been implemented to reduce the use of hazardous substances and/or emissions.

All Union components are compliant with the RoHS directive, which helps to support customers in their compliance with environmental directives. For more green compliance information, please visit:

<https://www.union-ic.com/Quality.html>

IMPORTANT NOTICE

The information in this document has been carefully reviewed and is believed to be accurate. Nonetheless, this document is subject to change without notice. Union assumes no responsibility for any inaccuracies that may be contained in this document, and makes no commitment to update or to keep current the contained information, or to notify a person or organization of any update. Union reserves the right to make changes, at any time, in order to improve reliability, function or design and to attempt to supply the best product possible.