

2-Bit Dual-Supply Bus Transceiver With Configurable Voltage Translation and 3-State Outputs

UM74AVC2T45A8 SSOP8
UM74AVC2T45S SOT23-8
UM74AVC2T45M8 MSOP8
UM74AVC2T45V8 VSSOP8

1 Description

The UM74AVC2T45 is a 2-bit non-inverting bus transceiver using two separate configurable power-supply rails. The A ports are designed to track V_{CCA} and accept supply voltage from 1V to 3.6V. The B ports are designed to track V_{CCB} and accept supply voltage from 1V to 3.6V. This meets the needs for universal low-voltage bidirectional translation and level-shifting between any of the 1.2V, 1.5V, 1.8V, 2.5V, and 3.3V voltage nodes.

The device transmits data from the A bus to the B bus or from the B bus to the A bus, depending on the logic level of the direction-control input (DIR). The direction-control pin (DIR) is referenced to V_{CCA} voltage. The input circuitry on both A and B ports always is active and must have a logic High or Low level applied to prevent excess leakage current on the internal CMOS structure.

The V_{CC} isolation feature is designed so that if either V_{CC} input supply is below 100mV, all level shifter outputs are disabled and placed into a high impedance state.

The UM74AVC2T45 series are available in SSOP8, SOT23-8, MSOP8 and VSSOP8 packages.

2 Applications

- Enterprise and communications
- Industrial
- Personal electronics
- Wireless infrastructure
- Building automation
- Point of sale

3 Features

- Control input V_{IH}/V_{IL} levels are referenced to V_{CCA} voltage
- V_{CC} isolation feature – if either V_{CC} input is at GND, all are in the high-impedance state
- Fully configurable dual-rail design allows each port to operate over the full 1V to 3.6V power supply range
- I_{OFF} supports partial power-down mode operation
- Latch-up performance exceeds 200 mA per JESD 78
- ESD protection on A and B ports
 - ± 8 kV Human body model
 - ± 2 kV Charged-device model
- Up to 400Mbps support when translating from 1.8V to 3.3V

4 Logic Diagram of UM74AVC2T45

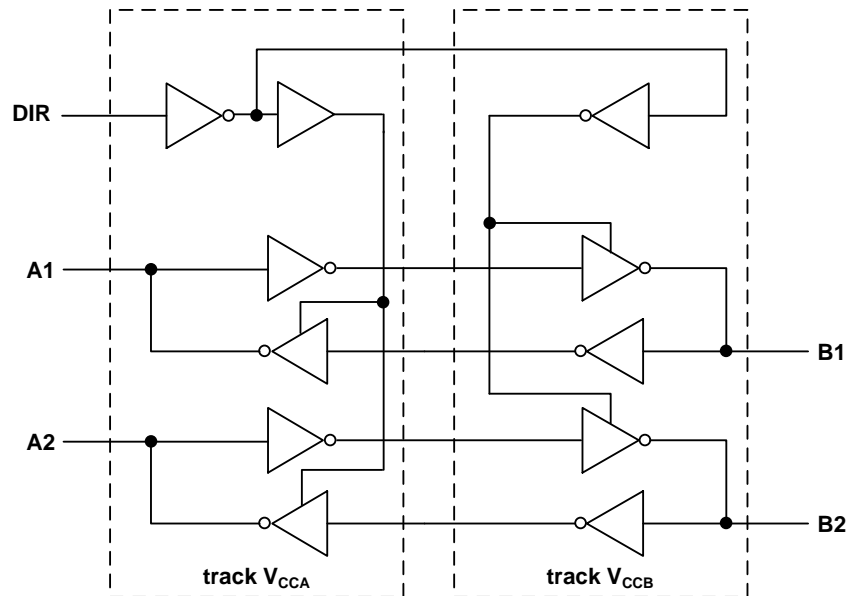

5 Ordering Information

Part Number	Mark Code	Package Type	Shipping Qty
UM74AVC2T45A8	SAD	SSOP8	3000pcs/7Inch Tape & Reel
UM74AVC2T45S	DA5	SOT23-8	3000pcs/7Inch Tape & Reel
UM74AVC2T45M8	2T45	MSOP8	4000pcs/13Inch Tape & Reel
UM74AVC2T45V8	VK	VSSOP8	3000pcs/7Inch Tape & Reel

6 Pin Configuration and Function

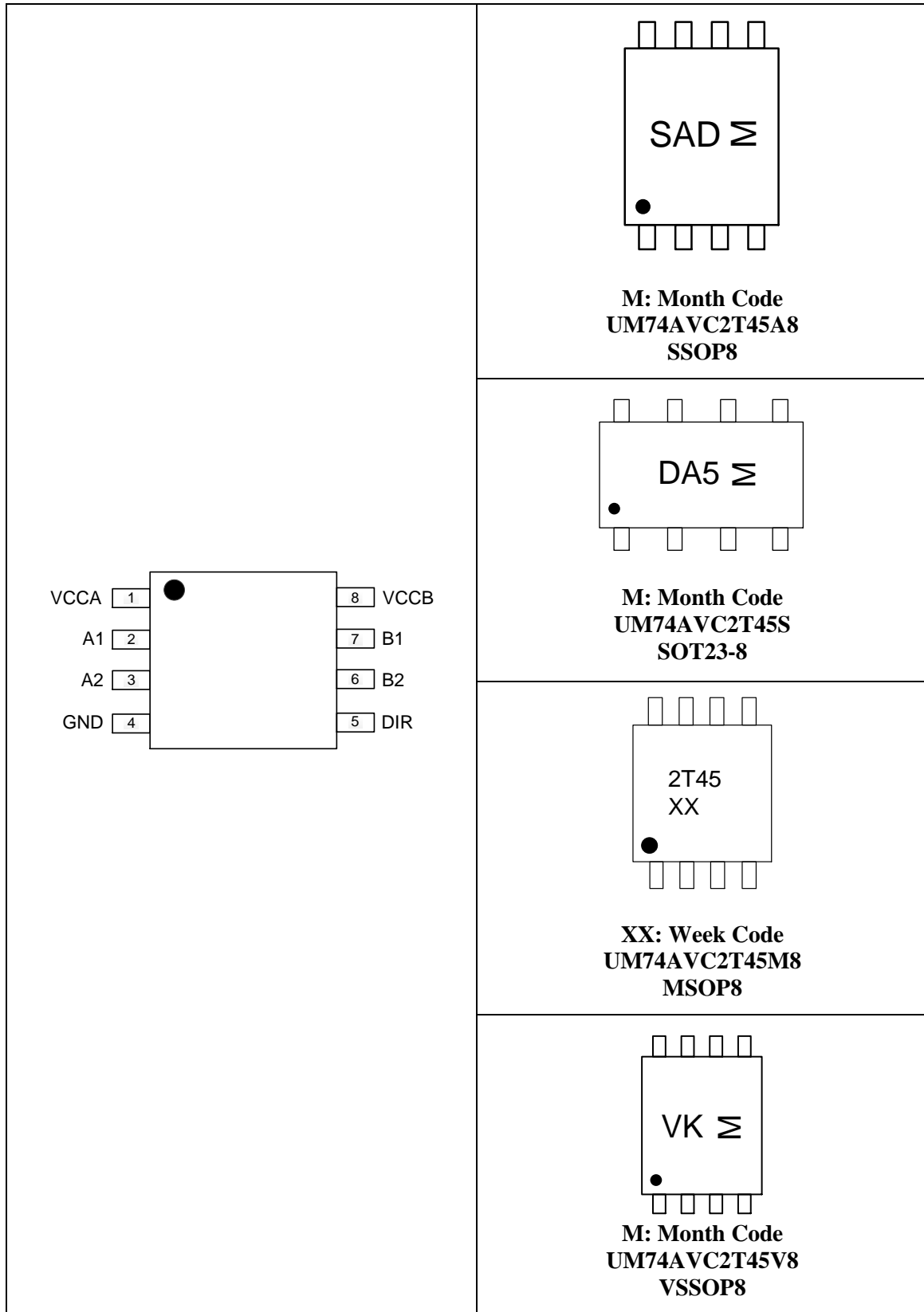

6 Pin Configuration and Function (continued)

Table 6-1. Pin Functions

Pin No.	Pin Name	Function
1	VCCA	A-port supply voltage. $1V \leq V_{CCA} \leq 3.6V$.
2	A1	Input/output A1. Output or input depending on state of DIR. Referenced to V_{CCA} .
3	A2	Input/output A2. Output or input depending on state of DIR. Referenced to V_{CCA} .
4	GND	Ground.
5	DIR	Direction-control input. Referenced to V_{CCA} .
6	B2	Input/output B2. Output or input depending on state of DIR. Referenced to V_{CCB} .
7	B1	Input/output B1. Output or input depending on state of DIR. Referenced to V_{CCB} .
8	VCCB	B-port supply voltage. $1V \leq V_{CCB} \leq 3.6V$.

7 Specifications

7.1 Absolute Maximum Ratings (Note 1)

Symbol	Parameter		Value	Unit
V _{CCA}	Supply Voltage		-0.5 to +4.6	V
V _{CCB}	Supply Voltage		-0.5 to +4.6	V
V _I	Input Voltage (Note 2)	A ports	-0.5 to +4.6	V
		B ports	-0.5 to +4.6	
		Control input	-0.5 to +4.6	
V _O	Voltage applied to any output in the high-impedance or Power-Off State (Note 2)	A ports	-0.5 to +4.6	V
		B ports	-0.5 to +4.6	
V _O	Voltage Range Applied to Any Output in the High or Low State (Note 2, 3)	A ports	-0.5 to (V _{CCA} +0.5)	V
		B ports	-0.5 to (V _{CCB} +0.5)	
V _{ESD}	Human-body model (HBM), per ANSI/ESDA/JEDEC JS-001	A and B pins	±8	kV
		Other pins	±4	kV
	Charged-device model (CDM), per ANSI/ESDA/JEDEC JS-002	All pins	±2	kV
I _{IK}	Input clamp current	V _I <0	-50	mA
I _{OK}	Output clamp current	V _O <0	-50	mA
I _O	Continuous Output Current		±50	mA
	Continuous Current through V _{CCA} , V _{CCB} , or GND		±100	mA
T _J	Operating Junction Temperature		-40 to +150	°C
T _{STG}	Storage Temperature		-65 to +150	°C

Note 1: Stresses beyond those listed under "Absolute Maximum Ratings" may cause permanent damage to the device. These are stress ratings only, and functional operation of the device at these or any other conditions beyond those indicated under "Recommended Operating Conditions" is not implied. Exposure to absolute-maximum-rated conditions for extended periods may affect device reliability.

Note 2: The input and output negative-voltage ratings may be exceeded if the input and output current ratings are observed.

Note 3: The output positive-voltage rating may be exceeded up to 4.6 V maximum if the output current rating is observed.

7.2 Recommended Operating Conditions (Note 1, 2, 3)

Over recommended operating free-air temperature range (unless otherwise noted).

Symbol	Parameter		V _{CCI}	V _{CCO}	Min	Max	Unit
V _{CCA}	Supply voltage				1	3.6	V
V _{CCB}					1	3.6	
V _{IH}	High-level input voltage	Data inputs	1V		V _{CCI} ×0.7		V
			1.1 V to 1.95 V		V _{CCI} ×0.65		
			1.95 V to 2.7 V		1.6		
			2.7V to 3.6 V		2		
V _{IL}	Low-level input voltage	Data inputs	1V		V _{CCI} ×0.3		V
			1.1 V to 1.95 V		V _{CCI} ×0.35		
			1.95 V to 2.7 V		0.7		
			2.7V to 3.6 V		0.8		
V _{IH}	High-level input voltage	Control input (DIR) referenced to V _{CCA}	1V		V _{CCI} ×0.7		V
			1.1 V to 1.95 V		V _{CCI} ×0.65		
			1.95 V to 2.7 V		1.6		
			2.7V to 3.6 V		2		
V _{IL}	Low-level input voltage	Control input (DIR) referenced to V _{CCA}	1V		V _{CCI} ×0.3		V
			1.1 V to 1.95 V		V _{CCI} ×0.35		
			1.95 V to 2.7 V		0.7		
			2.7V to 3.6 V		0.8		
V _I	Input voltage			0	3.6	V	
V _O	Output voltage	Active state		0	V _{CCO}	V	
		Three-State		0	3.6		
I _{OH}	High-level output current		1.1V to 1.3 V		-3	mA	
			1.4 V to 1.6 V		-6		
			1.65 V to 1.95 V		-8		
			2.3 V to 2.7 V		-9		
			3 V to 3.6 V		-12		
I _{OL}	Low-level output current		1.1V to 1.3 V		3	mA	
			1.4 V to 1.6 V		6		
			1.65 V to 1.95 V		8		
			2.3 V to 2.7 V		9		
			3 V to 3.6 V		12		
Δt/ΔV	Input transition rise or fall rate				10	ns/V	
T _A	Operating free-air temperature			-40	125	°C	

Note 1: V_{CCI} is the V_{CC} associated with the input port.

Note 2: V_{CCO} is the V_{CC} associated with the output port.

Note 3: All unused or driven (floating) data inputs (I/Os) of the device must be held at logic High or Low (preferably V_{CCI} or GND) to ensure proper device operation and minimize power.

7.3 Package Thermal Impedance

Symbol	Parameter		Value	Unit
$R_{\theta JA}$	Junction-to-ambient thermal resistance	SSOP8	182.5	°C/W
		SOT23-8	202.4	
		MSOP8	175.8	
		VSSOP8	244.3	
$R_{\theta JC(TOP)}$	Junction-to-case (top) thermal resistance	SSOP8	100.8	°C/W
		SOT23-8	120.7	
		MSOP8	68.9	
		VSSOP8	94.3	
$R_{\theta JB}$	Junction-to-board thermal resistance	SSOP8	109.6	°C/W
		SOT23-8	99.0	
		MSOP8	96.9	
		VSSOP8	155.7	

7.4 Electrical Characteristics (Note 1, 2)

Over recommended operating free-air temperature range (unless otherwise noted).

Parameter		Test Conditions	V _{CCA}	V _{CCB}	Min	Typ	Max	Unit	
V _{OH}		I _{OH} =-100μA I _{OH} =-3mA I _{OH} =-6mA I _{OH} =-8mA I _{OH} =-9mA I _{OH} =-12mA	V _I =V _{IH}	1V to 3.6V	1V to 3.6V	V _{CCO} -0.2			V
				1.1V	1.1V	0.85	0.98		
				1.4V	1.4V	1			
				1.65V	1.65V	1.2			
				2.3V	2.3V	1.8			
				3V	3V	2.4			
V _{OL}		I _{OL} =100μA I _{OL} =3mA I _{OL} =6mA I _{OL} =8mA I _{OL} =9mA I _{OL} =12mA	V _I =V _{IL}	1V to 3.6V	1V to 3.6V			0.2	V
				1.1V	1.1V		0.1	0.25	
				1.4V	1.4V			0.35	
				1.65V	1.65V			0.45	
				2.3V	2.3V			0.55	
				3V	3V			0.7	
I _I	Control inputs	V _I = V _{CCA} or GND	1V to 3.6V	1V to 3.6V	-1	0.1	1	μA	
I _{OZ}	A or B Port	V _O = V _{CCO} or GND, V _I = V _{CCI} or GND	0V	3.6V	-5	0.1	5	μA	
			3.6V	0V	-5	0.1	5	μA	
I _{OFF}	A or B Port	V _I or V _O = 0 to 3.6V	0V	0V to 3.6V	-5	0.1	5	μA	
			0V to 3.6V	0V	-5	0.1	5		
I _{CCA}		V _I =V _{CCI} or GND I _O =0	1V to 3.6V	1V to 3.6V			8	μA	
			0V	3.6V	-2				
			3.6V	0V			8		
I _{CCB}		V _I =V _{CCI} or GND I _O =0	1V to 3.6V	1V to 3.6V			8	μA	
			0V	3.6V			8		
			3.6V	0V	-2				
I _{CCA} +I _{CCB}		V _I =V _{CCI} or GND I _O =0	1V to 3.6V	1V to 3.6V			16	μA	
C _I	Control inputs	V _I = 3.3V or GND	3.3V	3.3V			7.5	pF	
C _{IO}	A or B Port	V _O = 3.3V or GND	3.3V	3.3V			8.5	pF	

Note 1: V_{CCI} is the V_{CC} associated with the input port.

Note 2: V_{CCO} is the V_{CC} associated with the output port.

7.5 Switching Characteristics

Over recommended operating free-air temperature range, $V_{CCA} = 1V$.

Parameter	From (Input)	To (Output)	V_{CCB}	Min	Typ	Max	Unit
t_{PLH}, t_{PHL}	A	B	$V_{CCB}=1V$	0.5		30	ns
			$V_{CCB}=1.2V \pm 0.1V$	0.5		20	
			$V_{CCB}=1.5V \pm 0.1V$	0.5		17	
			$V_{CCB}=1.8V \pm 0.15V$	0.5		15	
			$V_{CCB}=2.5V \pm 0.2V$	0.5		15	
			$V_{CCB}=3.3V \pm 0.3V$	0.5		17	
t_{PLH}, t_{PHL}	B	A	$V_{CCB}=1V$	0.5		30	ns
			$V_{CCB}=1.2V \pm 0.1V$	0.5		20	
			$V_{CCB}=1.5V \pm 0.1V$	0.5		17	
			$V_{CCB}=1.8V \pm 0.15V$	0.5		15	
			$V_{CCB}=2.5V \pm 0.2V$	0.5		17	
			$V_{CCB}=3.3V \pm 0.3V$	0.5		17	
t_{PZH}, t_{PZL}	DIR	A	$V_{CCB}=1V$	0.5		40	ns
			$V_{CCB}=1.2V \pm 0.1V$	0.5		35	
			$V_{CCB}=1.5V \pm 0.1V$	0.5		35	
			$V_{CCB}=1.8V \pm 0.15V$	0.5		35	
			$V_{CCB}=2.5V \pm 0.2V$	0.5		35	
			$V_{CCB}=3.3V \pm 0.3V$	0.5		35	
t_{PZH}, t_{PZL}	DIR	B	$V_{CCB}=1V$	0.5		40	ns
			$V_{CCB}=1.2V \pm 0.1V$	0.5		35	
			$V_{CCB}=1.5V \pm 0.1V$	0.5		35	
			$V_{CCB}=1.8V \pm 0.15V$	0.5		35	
			$V_{CCB}=2.5V \pm 0.2V$	0.5		35	
			$V_{CCB}=3.3V \pm 0.3V$	0.5		35	
t_{PHZ}, t_{PLZ}	DIR	A	$V_{CCB}=1V$	0.5		35	ns
			$V_{CCB}=1.2V \pm 0.1V$	0.5		35	
			$V_{CCB}=1.5V \pm 0.1V$	0.5		35	
			$V_{CCB}=1.8V \pm 0.15V$	0.5		35	
			$V_{CCB}=2.5V \pm 0.2V$	0.5		35	
			$V_{CCB}=3.3V \pm 0.3V$	0.5		35	
t_{PHZ}, t_{PLZ}	DIR	B	$V_{CCB}=1V$	0.5		40	ns
			$V_{CCB}=1.2V \pm 0.1V$	0.5		35	
			$V_{CCB}=1.5V \pm 0.1V$	0.5		35	
			$V_{CCB}=1.8V \pm 0.15V$	0.5		35	
			$V_{CCB}=2.5V \pm 0.2V$	0.5		35	
			$V_{CCB}=3.3V \pm 0.3V$	0.5		35	

7.5 Switching Characteristics (continued)

Over recommended operating free-air temperature range, $V_{CCA} = 1.2V \pm 0.1V$.

Parameter	From (Input)	To (Output)	V_{CCB}	Min	Typ	Max	Unit
t_{PLH}, t_{PHL}	A	B	$V_{CCB}=1V$	0.5		23	ns
			$V_{CCB}=1.2V \pm 0.1V$	0.5		15	
			$V_{CCB}=1.5V \pm 0.1V$	0.5		10	
			$V_{CCB}=1.8V \pm 0.15V$	0.5		9	
			$V_{CCB}=2.5V \pm 0.2V$	0.5		7	
			$V_{CCB}=3.3V \pm 0.3V$	0.5		7.5	
t_{PLH}, t_{PHL}	B	A	$V_{CCB}=1V$	0.5		23	ns
			$V_{CCB}=1.2V \pm 0.1V$	0.5		15	
			$V_{CCB}=1.5V \pm 0.1V$	0.5		13	
			$V_{CCB}=1.8V \pm 0.15V$	0.5		11	
			$V_{CCB}=2.5V \pm 0.2V$	0.5		8	
			$V_{CCB}=3.3V \pm 0.3V$	0.5		7	
t_{PZH}, t_{PZL}	DIR	A	$V_{CCB}=1V$	0.5		30	ns
			$V_{CCB}=1.2V \pm 0.1V$	0.5		30	
			$V_{CCB}=1.5V \pm 0.1V$	0.5		30	
			$V_{CCB}=1.8V \pm 0.15V$	0.5		30	
			$V_{CCB}=2.5V \pm 0.2V$	0.5		30	
			$V_{CCB}=3.3V \pm 0.3V$	0.5		30	
t_{PZH}, t_{PZL}	DIR	B	$V_{CCB}=1V$	0.5		30	ns
			$V_{CCB}=1.2V \pm 0.1V$	0.5		25	
			$V_{CCB}=1.5V \pm 0.1V$	0.5		25	
			$V_{CCB}=1.8V \pm 0.15V$	0.5		25	
			$V_{CCB}=2.5V \pm 0.2V$	0.5		25	
			$V_{CCB}=3.3V \pm 0.3V$	0.5		25	
t_{PHZ}, t_{PLZ}	DIR	A	$V_{CCB}=1V$	0.5		35	ns
			$V_{CCB}=1.2V \pm 0.1V$	0.5		30	
			$V_{CCB}=1.5V \pm 0.1V$	0.5		30	
			$V_{CCB}=1.8V \pm 0.15V$	0.5		30	
			$V_{CCB}=2.5V \pm 0.2V$	0.5		30	
			$V_{CCB}=3.3V \pm 0.3V$	0.5		30	
t_{PHZ}, t_{PLZ}	DIR	B	$V_{CCB}=1V$	0.5		35	ns
			$V_{CCB}=1.2V \pm 0.1V$	0.5		30	
			$V_{CCB}=1.5V \pm 0.1V$	0.5		30	
			$V_{CCB}=1.8V \pm 0.15V$	0.5		30	
			$V_{CCB}=2.5V \pm 0.2V$	0.5		30	
			$V_{CCB}=3.3V \pm 0.3V$	0.5		30	

7.5 Switching Characteristics (continued)

Over recommended operating free-air temperature range, $V_{CCA} = 1.5V \pm 0.1V$.

Parameter	From (Input)	To (Output)	V_{CCB}	Min	Typ	Max	Unit
t_{PLH}, t_{PHL}	A	B	$V_{CCB}=1V$	0.5		18	ns
			$V_{CCB}=1.2V \pm 0.1V$	0.5		13	
			$V_{CCB}=1.5V \pm 0.1V$	0.5		9	
			$V_{CCB}=1.8V \pm 0.15V$	0.5		7	
			$V_{CCB}=2.5V \pm 0.2V$	0.5		6	
			$V_{CCB}=3.3V \pm 0.3V$	0.5		5.5	
t_{PLH}, t_{PHL}	B	A	$V_{CCB}=1V$	0.5		17	ns
			$V_{CCB}=1.2V \pm 0.1V$	0.5		11	
			$V_{CCB}=1.5V \pm 0.1V$	0.5		9	
			$V_{CCB}=1.8V \pm 0.15V$	0.5		7.5	
			$V_{CCB}=2.5V \pm 0.2V$	0.5		6	
			$V_{CCB}=3.3V \pm 0.3V$	0.5		5	
t_{PZH}, t_{PZL}	DIR	A	$V_{CCB}=1V$	0.5		25	ns
			$V_{CCB}=1.2V \pm 0.1V$	0.5		23	
			$V_{CCB}=1.5V \pm 0.1V$	0.5		23	
			$V_{CCB}=1.8V \pm 0.15V$	0.5		23	
			$V_{CCB}=2.5V \pm 0.2V$	0.5		23	
			$V_{CCB}=3.3V \pm 0.3V$	0.5		23	
t_{PZH}, t_{PZL}	DIR	B	$V_{CCB}=1V$	0.5		27	ns
			$V_{CCB}=1.2V \pm 0.1V$	0.5		24	
			$V_{CCB}=1.5V \pm 0.1V$	0.5		20	
			$V_{CCB}=1.8V \pm 0.15V$	0.5		20	
			$V_{CCB}=2.5V \pm 0.2V$	0.5		20	
			$V_{CCB}=3.3V \pm 0.3V$	0.5		20	
t_{PHZ}, t_{PLZ}	DIR	A	$V_{CCB}=1V$	0.5		34	ns
			$V_{CCB}=1.2V \pm 0.1V$	0.5		34	
			$V_{CCB}=1.5V \pm 0.1V$	0.5		34	
			$V_{CCB}=1.8V \pm 0.15V$	0.5		34	
			$V_{CCB}=2.5V \pm 0.2V$	0.5		34	
			$V_{CCB}=3.3V \pm 0.3V$	0.5		34	
t_{PHZ}, t_{PLZ}	DIR	B	$V_{CCB}=1V$	0.5		45	ns
			$V_{CCB}=1.2V \pm 0.1V$	0.5		40	
			$V_{CCB}=1.5V \pm 0.1V$	0.5		35	
			$V_{CCB}=1.8V \pm 0.15V$	0.5		31	
			$V_{CCB}=2.5V \pm 0.2V$	0.5		28	
			$V_{CCB}=3.3V \pm 0.3V$	0.5		25	

7.5 Switching Characteristics (continued)

Over recommended operating free-air temperature range, $V_{CCA} = 1.8V \pm 0.15V$.

Parameter	From (Input)	To (Output)	V_{CCB}	Min	Typ	Max	Unit
t_{PLH}, t_{PHL}	A	B	$V_{CCB}=1V$	0.5		16	ns
			$V_{CCB}=1.2V \pm 0.1V$	0.5		11	
			$V_{CCB}=1.5V \pm 0.1V$	0.5		8	
			$V_{CCB}=1.8V \pm 0.15V$	0.5		7	
			$V_{CCB}=2.5V \pm 0.2V$	0.5		6	
			$V_{CCB}=3.3V \pm 0.3V$	0.5		5	
t_{PLH}, t_{PHL}	B	A	$V_{CCB}=1V$	0.5		16	ns
			$V_{CCB}=1.2V \pm 0.1V$	0.5		10	
			$V_{CCB}=1.5V \pm 0.1V$	0.5		7	
			$V_{CCB}=1.8V \pm 0.15V$	0.5		7	
			$V_{CCB}=2.5V \pm 0.2V$	0.5		5	
			$V_{CCB}=3.3V \pm 0.3V$	0.5		4	
t_{PZH}, t_{PZL}	DIR	A	$V_{CCB}=1V$	0.5		23	ns
			$V_{CCB}=1.2V \pm 0.1V$	0.5		20	
			$V_{CCB}=1.5V \pm 0.1V$	0.5		17	
			$V_{CCB}=1.8V \pm 0.15V$	0.5		17	
			$V_{CCB}=2.5V \pm 0.2V$	0.5		17	
			$V_{CCB}=3.3V \pm 0.3V$	0.5		17	
t_{PZH}, t_{PZL}	DIR	B	$V_{CCB}=1V$	0.5		23	ns
			$V_{CCB}=1.2V \pm 0.1V$	0.5		23	
			$V_{CCB}=1.5V \pm 0.1V$	0.5		17	
			$V_{CCB}=1.8V \pm 0.15V$	0.5		15	
			$V_{CCB}=2.5V \pm 0.2V$	0.5		15	
			$V_{CCB}=3.3V \pm 0.3V$	0.5		15	
t_{PHZ}, t_{PLZ}	DIR	A	$V_{CCB}=1V$	0.5		30	ns
			$V_{CCB}=1.2V \pm 0.1V$	0.5		30	
			$V_{CCB}=1.5V \pm 0.1V$	0.5		30	
			$V_{CCB}=1.8V \pm 0.15V$	0.5		30	
			$V_{CCB}=2.5V \pm 0.2V$	0.5		30	
			$V_{CCB}=3.3V \pm 0.3V$	0.5		30	
t_{PHZ}, t_{PLZ}	DIR	B	$V_{CCB}=1V$	0.5		30	ns
			$V_{CCB}=1.2V \pm 0.1V$	0.5		30	
			$V_{CCB}=1.5V \pm 0.1V$	0.5		30	
			$V_{CCB}=1.8V \pm 0.15V$	0.5		30	
			$V_{CCB}=2.5V \pm 0.2V$	0.5		30	
			$V_{CCB}=3.3V \pm 0.3V$	0.5		30	

7.5 Switching Characteristics (continued)

Over recommended operating free-air temperature range, $V_{CCA} = 2.5V \pm 0.2V$.

Parameter	From (Input)	To (Output)	V_{CCB}	Min	Typ	Max	Unit
t_{PLH}, t_{PHL}	A	B	$V_{CCB}=1V$	0.5		15	ns
			$V_{CCB}=1.2V \pm 0.1V$	0.5		8	
			$V_{CCB}=1.5V \pm 0.1V$	0.5		6	
			$V_{CCB}=1.8V \pm 0.15V$	0.5		5.5	
			$V_{CCB}=2.5V \pm 0.2V$	0.5		5	
			$V_{CCB}=3.3V \pm 0.3V$	0.5		4	
t_{PLH}, t_{PHL}	B	A	$V_{CCB}=1V$	0.5		15	ns
			$V_{CCB}=1.2V \pm 0.1V$	0.5		7.5	
			$V_{CCB}=1.5V \pm 0.1V$	0.5		6	
			$V_{CCB}=1.8V \pm 0.15V$	0.5		5.5	
			$V_{CCB}=2.5V \pm 0.2V$	0.5		5	
			$V_{CCB}=3.3V \pm 0.3V$	0.5		4	
t_{PZH}, t_{PZL}	DIR	A	$V_{CCB}=1V$	0.5		25	ns
			$V_{CCB}=1.2V \pm 0.1V$	0.5		20	
			$V_{CCB}=1.5V \pm 0.1V$	0.5		15	
			$V_{CCB}=1.8V \pm 0.15V$	0.5		15	
			$V_{CCB}=2.5V \pm 0.2V$	0.5		15	
			$V_{CCB}=3.3V \pm 0.3V$	0.5		15	
t_{PZH}, t_{PZL}	DIR	B	$V_{CCB}=1V$	0.5		21	ns
			$V_{CCB}=1.2V \pm 0.1V$	0.5		18	
			$V_{CCB}=1.5V \pm 0.1V$	0.5		15	
			$V_{CCB}=1.8V \pm 0.15V$	0.5		15	
			$V_{CCB}=2.5V \pm 0.2V$	0.5		15	
			$V_{CCB}=3.3V \pm 0.3V$	0.5		15	
t_{PHZ}, t_{PLZ}	DIR	A	$V_{CCB}=1V$	0.5		25	ns
			$V_{CCB}=1.2V \pm 0.1V$	0.5		25	
			$V_{CCB}=1.5V \pm 0.1V$	0.5		25	
			$V_{CCB}=1.8V \pm 0.15V$	0.5		25	
			$V_{CCB}=2.5V \pm 0.2V$	0.5		25	
			$V_{CCB}=3.3V \pm 0.3V$	0.5		25	
t_{PHZ}, t_{PLZ}	DIR	B	$V_{CCB}=1V$	0.5		35	ns
			$V_{CCB}=1.2V \pm 0.1V$	0.5		32	
			$V_{CCB}=1.5V \pm 0.1V$	0.5		30	
			$V_{CCB}=1.8V \pm 0.15V$	0.5		28	
			$V_{CCB}=2.5V \pm 0.2V$	0.5		25	
			$V_{CCB}=3.3V \pm 0.3V$	0.5		23	

7.5 Switching Characteristics (continued)

Over recommended operating free-air temperature range, $V_{CCA} = 3.3V \pm 0.3V$.

Parameter	From (Input)	To (Output)	V_{CCB}	Min	Typ	Max	Unit
t_{PLH}, t_{PHL}	A	B	$V_{CCB}=1V$	0.5		16	ns
			$V_{CCB}=1.2V \pm 0.1V$	0.5		7	
			$V_{CCB}=1.5V \pm 0.1V$	0.5		5	
			$V_{CCB}=1.8V \pm 0.15V$	0.5		4	
			$V_{CCB}=2.5V \pm 0.2V$	0.5		4	
			$V_{CCB}=3.3V \pm 0.3V$	0.5		4	
t_{PLH}, t_{PHL}	B	A	$V_{CCB}=1V$	0.5		16	ns
			$V_{CCB}=1.2V \pm 0.1V$	0.5		7	
			$V_{CCB}=1.5V \pm 0.1V$	0.5		6	
			$V_{CCB}=1.8V \pm 0.15V$	0.5		5	
			$V_{CCB}=2.5V \pm 0.2V$	0.5		4	
			$V_{CCB}=3.3V \pm 0.3V$	0.5		4	
t_{PZH}, t_{PZL}	DIR	A	$V_{CCB}=1V$	0.5		25	ns
			$V_{CCB}=1.2V \pm 0.1V$	0.5		20	
			$V_{CCB}=1.5V \pm 0.1V$	0.5		15	
			$V_{CCB}=1.8V \pm 0.15V$	0.5		15	
			$V_{CCB}=2.5V \pm 0.2V$	0.5		15	
			$V_{CCB}=3.3V \pm 0.3V$	0.5		15	
t_{PZH}, t_{PZL}	DIR	B	$V_{CCB}=1V$	0.5		25	ns
			$V_{CCB}=1.2V \pm 0.1V$	0.5		20	
			$V_{CCB}=1.5V \pm 0.1V$	0.5		15	
			$V_{CCB}=1.8V \pm 0.15V$	0.5		15	
			$V_{CCB}=2.5V \pm 0.2V$	0.5		15	
			$V_{CCB}=3.3V \pm 0.3V$	0.5		15	
t_{PHZ}, t_{PLZ}	DIR	A	$V_{CCB}=1V$	0.5		22	ns
			$V_{CCB}=1.2V \pm 0.1V$	0.5		22	
			$V_{CCB}=1.5V \pm 0.1V$	0.5		22	
			$V_{CCB}=1.8V \pm 0.15V$	0.5		22	
			$V_{CCB}=2.5V \pm 0.2V$	0.5		22	
			$V_{CCB}=3.3V \pm 0.3V$	0.5		22	
t_{PHZ}, t_{PLZ}	DIR	B	$V_{CCB}=1V$	0.5		36	ns
			$V_{CCB}=1.2V \pm 0.1V$	0.5		33	
			$V_{CCB}=1.5V \pm 0.1V$	0.5		30	
			$V_{CCB}=1.8V \pm 0.15V$	0.5		27	
			$V_{CCB}=2.5V \pm 0.2V$	0.5		25	
			$V_{CCB}=3.3V \pm 0.3V$	0.5		23	

7.6 Operating Characteristics (Note 1)

$T_A=25^{\circ}\text{C}$.

Parameter			Test Conditions	$V_{CCA} =$ $V_{CCB} =$ 1V	$V_{CCA} =$ $V_{CCB} =$ 1.2V	$V_{CCA} =$ $V_{CCB} =$ 1.5V	$V_{CCA} =$ $V_{CCB} =$ 1.8V	$V_{CCA} =$ $V_{CCB} =$ 2.5V	$V_{CCA} =$ $V_{CCB} =$ 3.3V	Unit
				Typ	Typ	Typ	Typ	Typ	Typ	
C_{PDA}	A to B	Outputs enabled	$C_L = 0,$ $f=10\text{MHz},$ $t_R = t_F = 1\text{ns}$	2	2.2	2.3	2.5	2.7	3.5	pF
		Outputs disabled		1	1	1	1	1	1	
	B to A	Outputs enabled		12	12	12	12	13	13.5	
		Outputs disabled		1	1	1	1	1	1	
C_{PDB}	A to B	Outputs enabled		12	12	12	12	13	13.5	
		Outputs disabled		1	1	1	1	1	1	
	B to A	Outputs enabled		2	2.2	2.3	2.5	2.7	3.5	
		Outputs disabled		1	1	1	1	1	1	

Note 1: C_{PDA} and C_{PDB} are power dissipation capacitance per transceiver.

8 Parameter Measurement Information

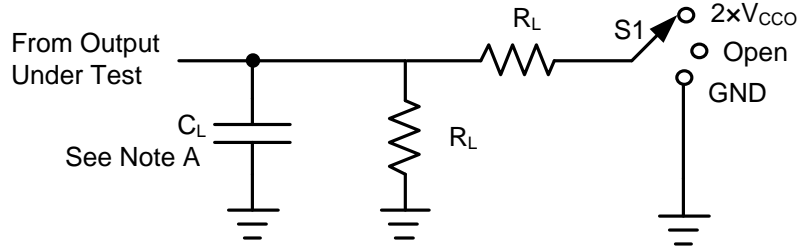

Figure 8-1. Load Circuit

Parameter	V _{CCO}	C _L	R _L	S1	V _{TP}
t _{PD}	1V to 3.6V	15pF	2kΩ	Open	N/A
t _{PLZ} , t _{PZL}	1V to 1.6V	15pF	2kΩ	2 × V _{CCO}	0.1V
	1.65V to 2.7V	15pF	2kΩ	2 × V _{CCO}	0.15V
	3V to 3.6V	15pF	2kΩ	2 × V _{CCO}	0.3V
t _{PHZ} , t _{PZH}	1V to 1.6V	15pF	2kΩ	GND	0.1V
	1.65V to 2.7V	15pF	2kΩ	GND	0.15V
	3V to 3.6V	15pF	2kΩ	GND	0.3V

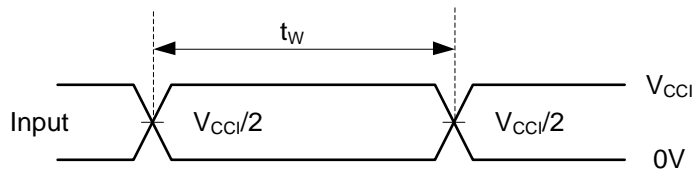

Figure 8-2. Voltage Waveforms Pulse Duration

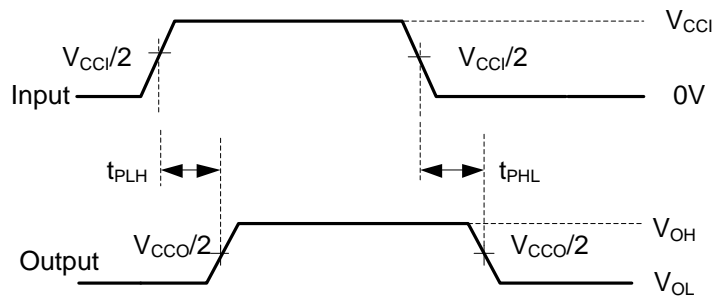

Figure 8-3. Voltage Waveforms Propagation Delay Times

8 Parameter Measurement Information (continued)

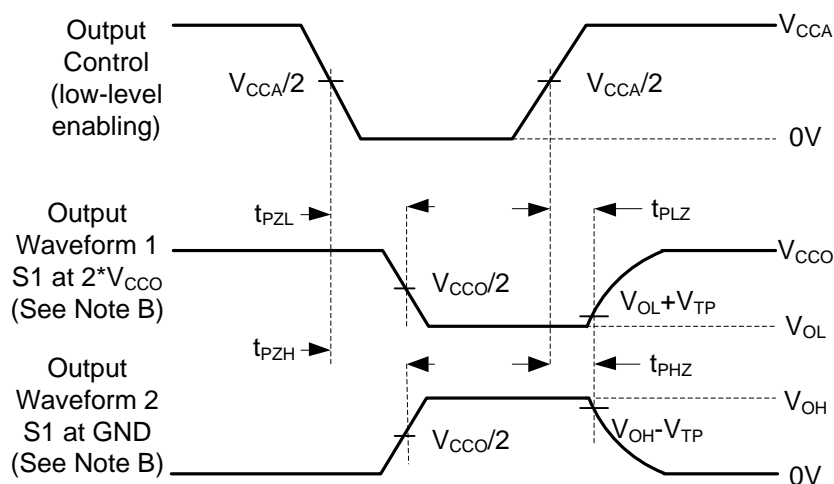

Figure 8-4. Voltage Waveforms Enable and Disable Times

Notes:

- A. C_L includes probe and jig capacitance.
- B. Waveform 1 is for an output with internal conditions such that the output is low, except when disabled by the output control. Waveform 2 is for an output with internal conditions such that the output is high, except when disabled by the output control.
- C. All input pulses are supplied by generators having the following characteristics: $PRR \leq 10$ MHz, $Z_O = 50\Omega$, $dv/dt \geq 1V/ns$.
- D. The outputs are measured one at a time, with one transition per measurement.
- E. t_{PLZ} and t_{PHZ} are the same as t_{DIS} .
- F. t_{PZL} and t_{PZH} are the same as t_{EN} .
- G. t_{PLH} and t_{PHL} are the same as t_{PD} .
- H. V_{CCI} is the V_{CC} associated with the input port.
- I. V_{CCO} is the V_{CC} associated with the output port.

9 Detailed Description

9.1 Overview

The UM74AVC2T45 device is a 2-bit, dual-supply non-inverting transceiver with bidirectional voltage level translation. The A ports are designed to track V_{CCA} and accept supply voltage from 1V to 3.6V. The B ports are designed to track V_{CCB} and accept supply voltage from 1V to 3.6V. This meets the needs for universal low-voltage bidirectional translation and level-shifting between any of the 1.2V, 1.5V, 1.8V, 2.5V, and 3.3V voltage nodes.

9.2 Functional Block Diagram

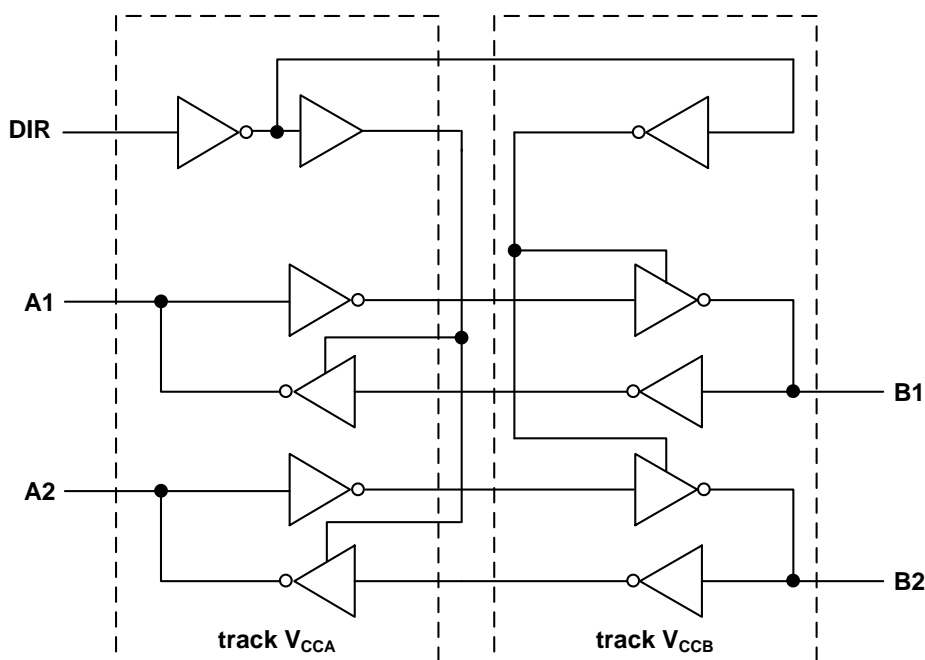

Figure 9-1. Logic Diagram of UM74AVC2T45

10 Feature Description

10.1 Fully Configurable Dual-Rail Design

The fully configurable dual-rail design allows each port to operate over the full 1 V to 3.6 V power-supply range. Both V_{CCA} and V_{CCB} can be supplied at any voltage between 1 V and 3.6 V making the device an excellent choice for translating between any of the low voltage nodes (1 V, 1.2 V, 1.8 V, 2.5 V and 3.3 V).

10.2 I_{OFF} Supports Partial-Power-Down Mode Operation

I_{OFF} prevents backflow current by disabling I/O output circuits when device is in partial power-down mode. The inputs and outputs for this device enter a high-impedance state when the device is powered down, inhibiting current backflow into the device. The maximum leakage into or out of any input or output pin on the device is specified by I_{OFF} in the Electrical Characteristics.

10.3 V_{CC} Isolation

The I/Os of both ports will enter a high-impedance state when one of the supplies are at GND, while the other supply is still connected to the device.

10.4 Device Functional Modes

All control inputs are referenced to V_{CCA} and must be driven to a valid Logic High or Logic Low (that is, not floating) to assure proper device operation and to prevent excessive power consumption. Table 10-1 summarizes the possible modes of device operation based on the configuration of the control inputs.

Table 10-1. Function Table

Control Input	Output Circuits		Operation
	A port	B port	
DIR			
L	Enabled	Hi-Z	B data to A bus
H	Hi-Z	Enabled	A data to B bus

11 Application Information

11.1 Application Information

The UM74AVC2T45 can be used in level-translation applications for interfacing devices or systems operating at different voltage nodes. Typical Application Circuit depicts an application in which the UM74AVC2T45 is up-translating a 1.8V input to a 3.3V output to interface between a system controller and a peripheral device.

11.2 Typical Application

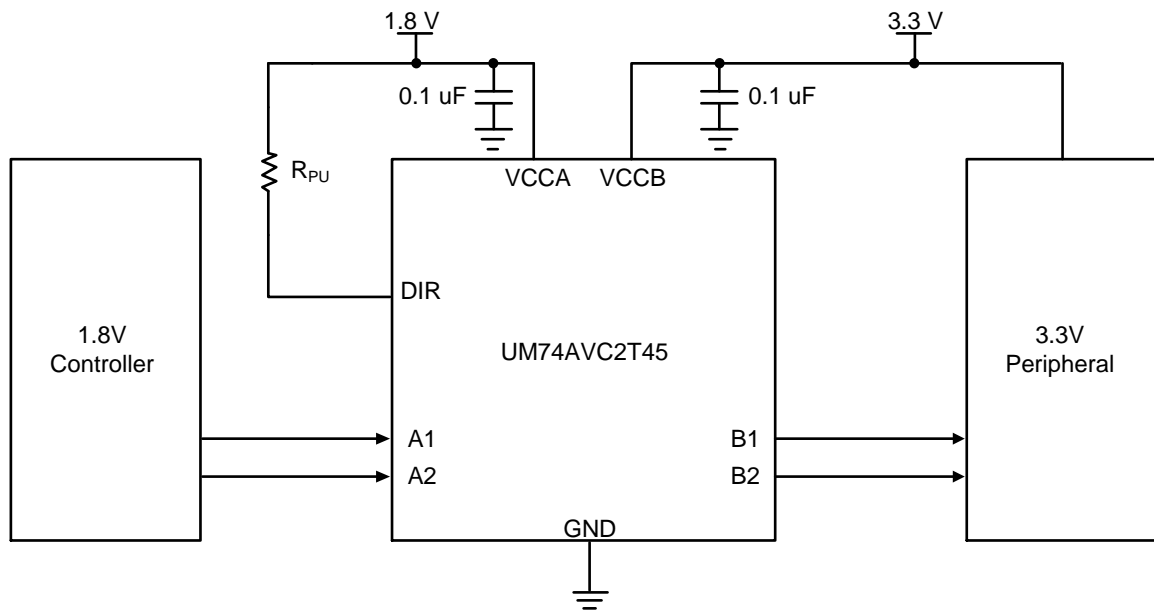
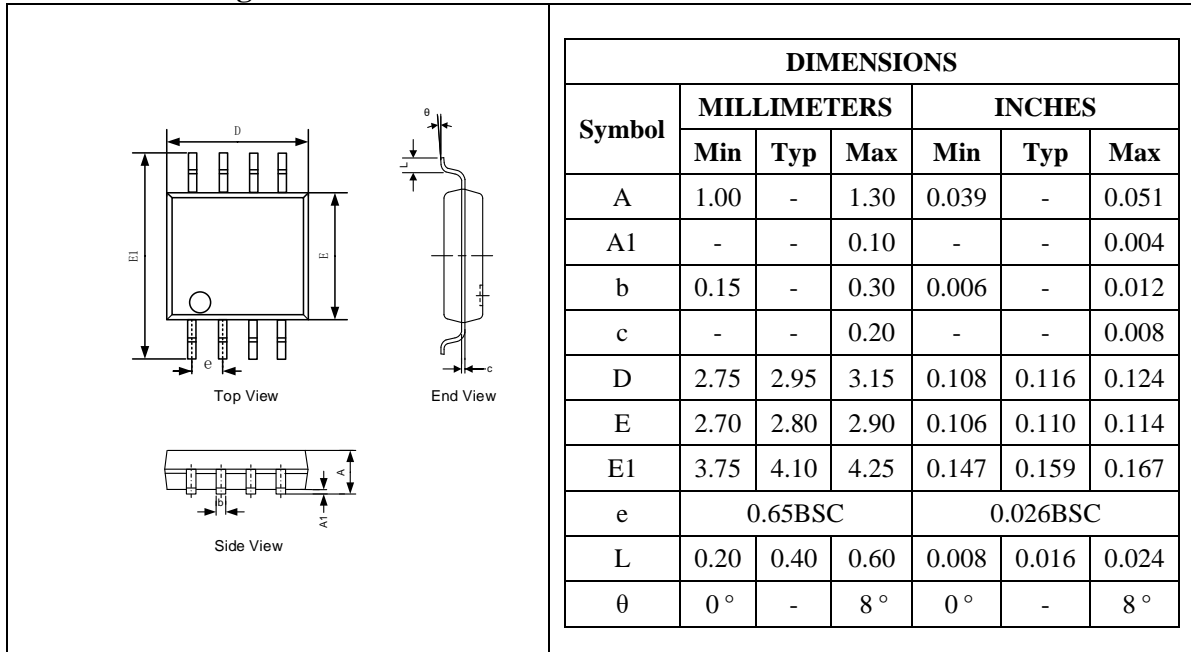

Figure 11-1. UM74AVC2T45 Typical Application

Package Information

SSOP8

Outline Drawing



Land Pattern

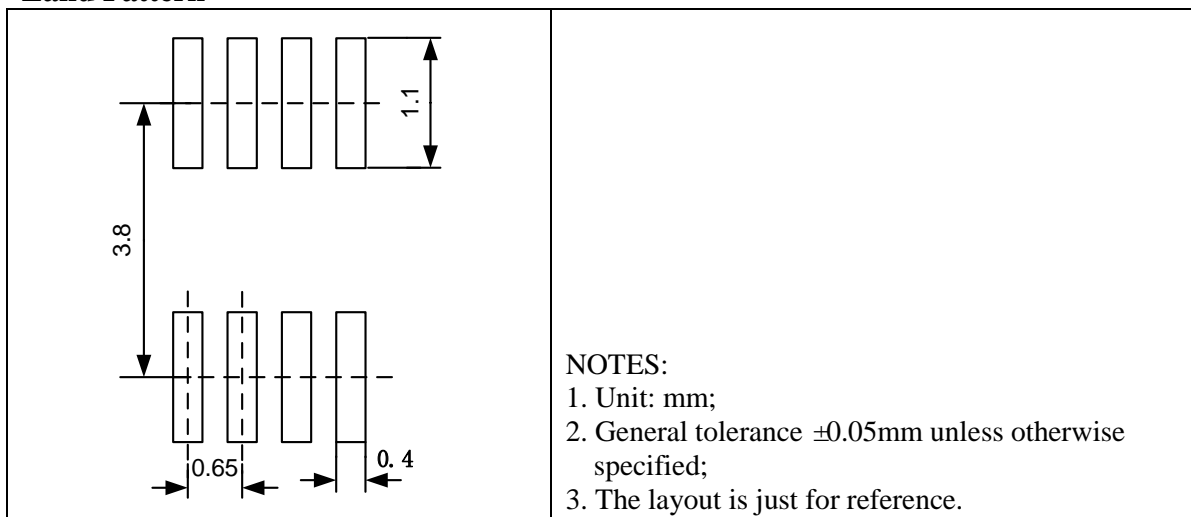

SOT23-8

Outline Drawing

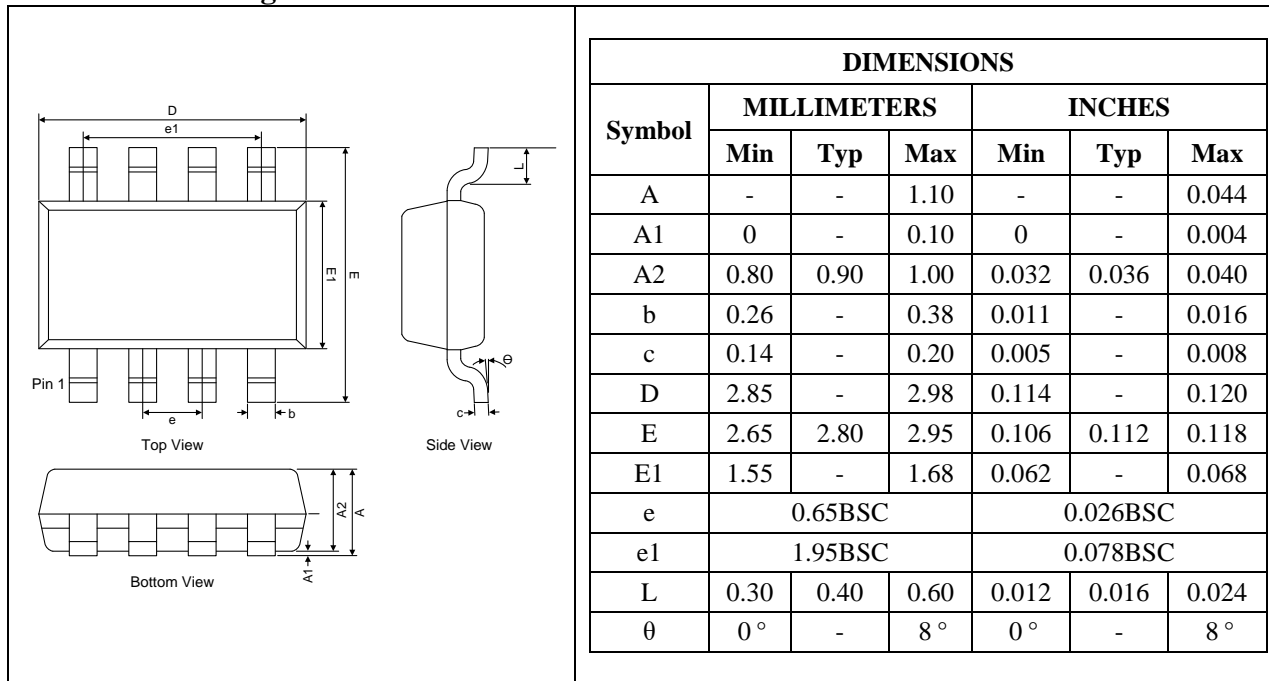

Land Pattern

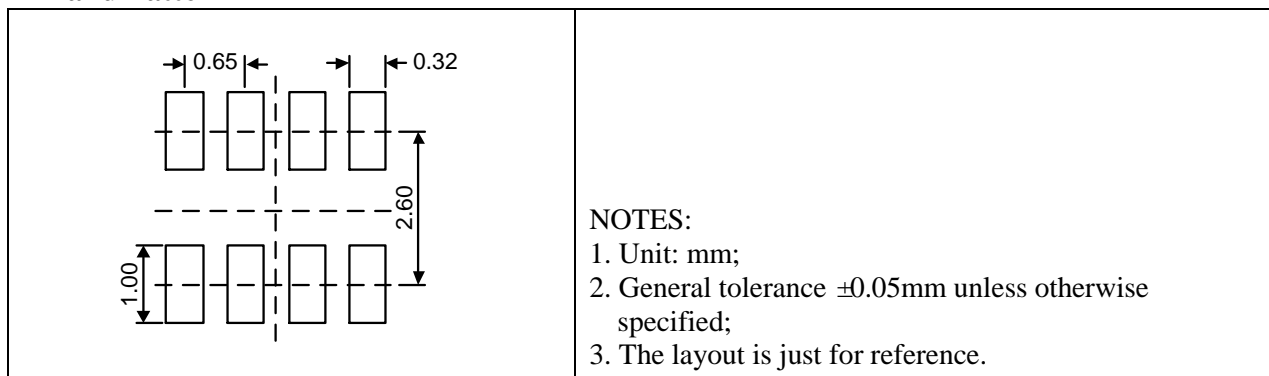

MSOP8

Outline Drawing

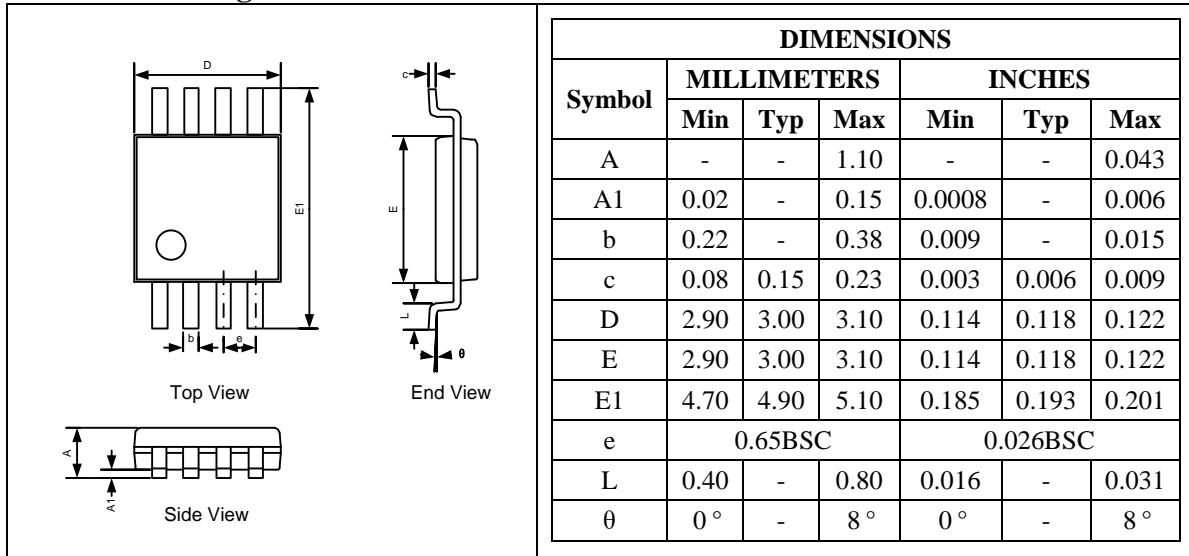

Land Pattern

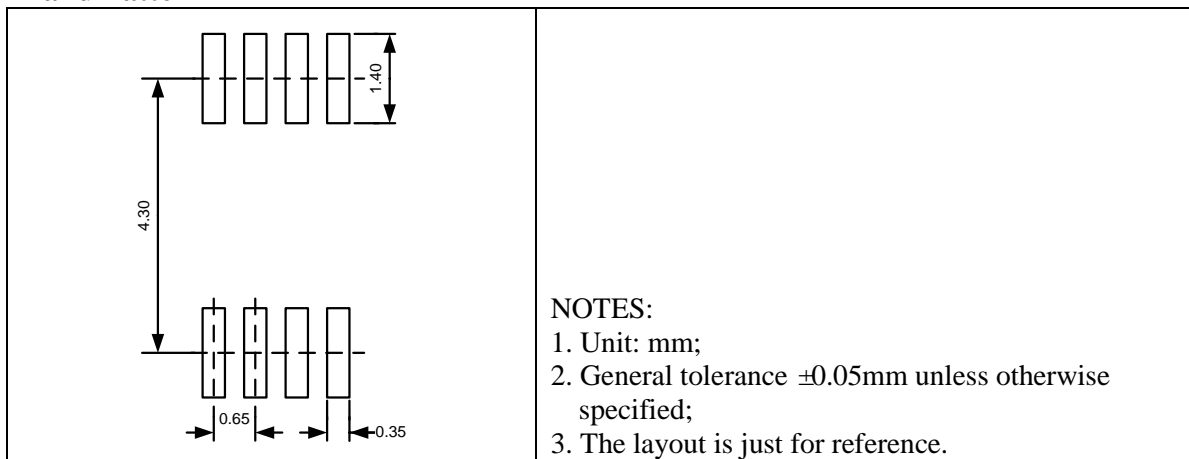

VSSOP8

Outline Drawing

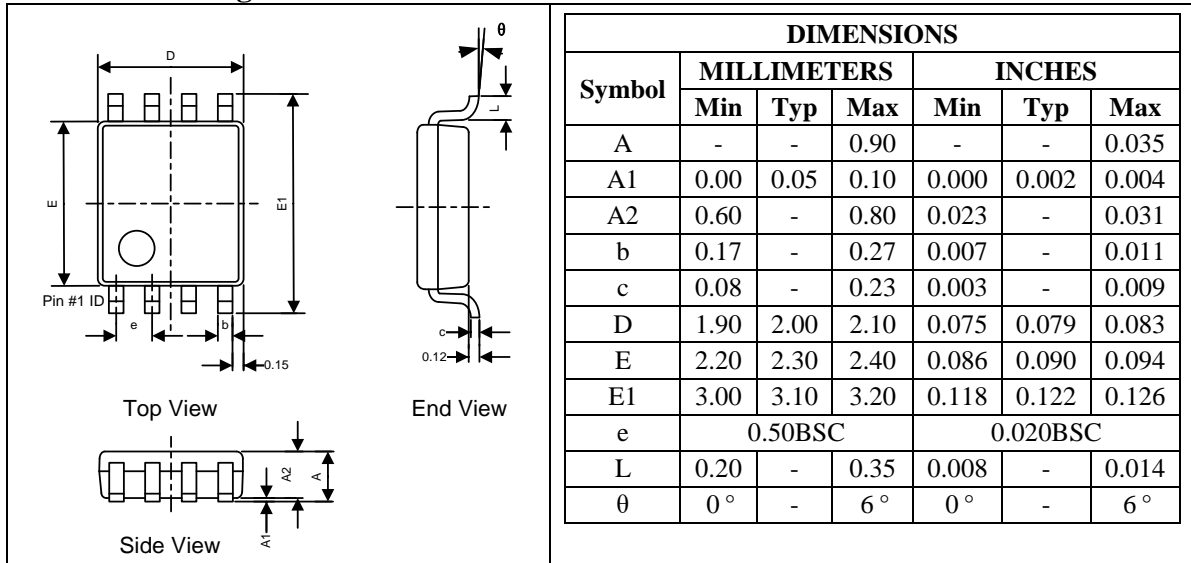

Land Pattern

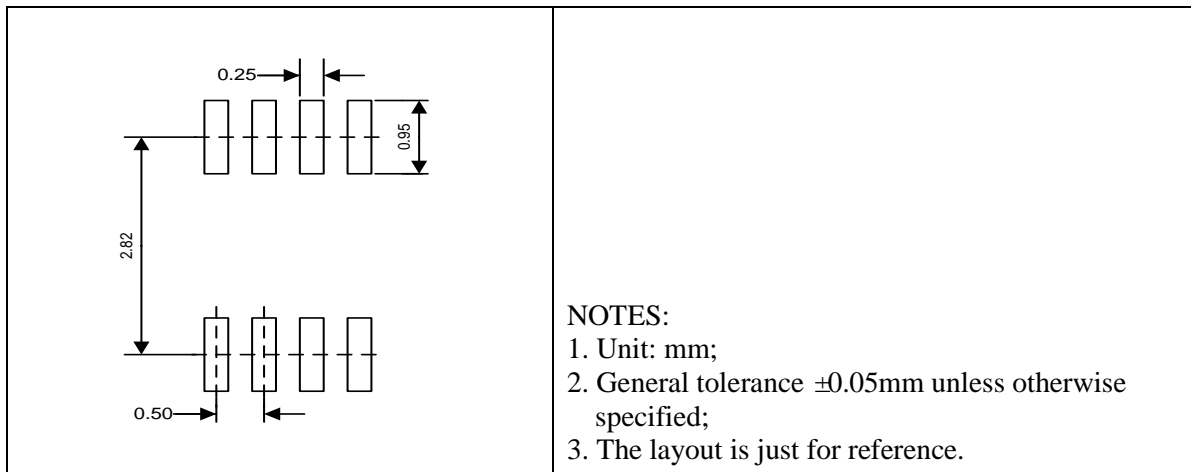

Packing Information

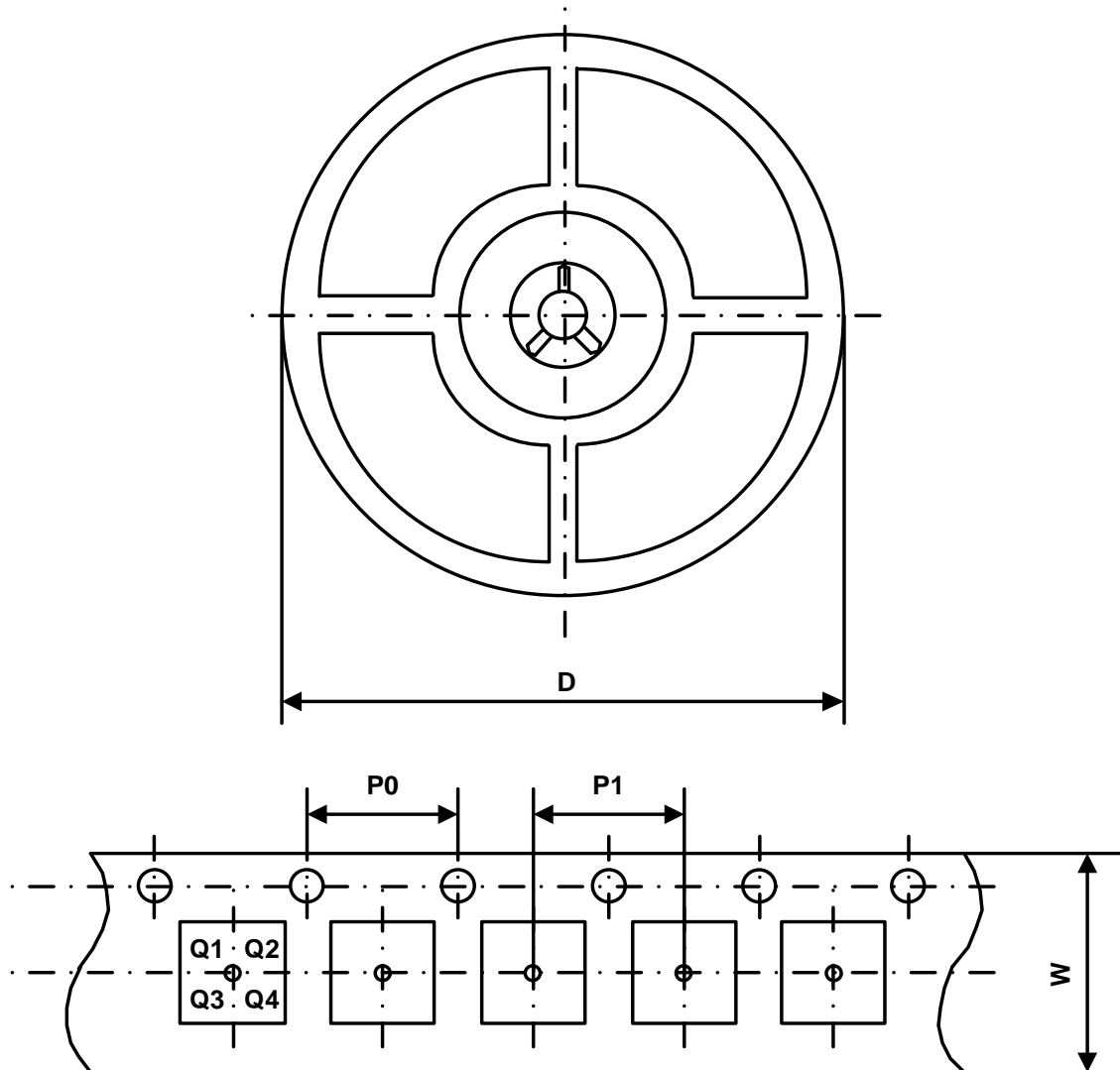

Part Number	Package Type	Carrier Width (W)	Pitch (P0)	Pitch (P1)	Reel Size (D)	PIN 1 Quadrant
UM74AVC2T45A8	SSOP8	12 mm	4 mm	4 mm	180 mm	Q3
UM74AVC2T45S	SOT23-8	8 mm	4 mm	4 mm	180 mm	Q3
UM74AVC2T45M8	MSOP8	12 mm	4 mm	8 mm	330 mm	Q1
UM74AVC2T45V8	VSSOP8	8 mm	4 mm	4 mm	180 mm	Q3

GREEN COMPLIANCE

Union Semiconductor is committed to environmental excellence in all aspects of its operations including meeting or exceeding regulatory requirements with respect to the use of hazardous substances. Numerous successful programs have been implemented to reduce the use of hazardous substances and/or emissions.

All Union components are compliant with the RoHS directive, which helps to support customers in their compliance with environmental directives. For more green compliance information, please visit:

<https://www.union-ic.com/Quality.html>

IMPORTANT NOTICE

The information in this document has been carefully reviewed and is believed to be accurate. Nonetheless, this document is subject to change without notice. Union assumes no responsibility for any inaccuracies that may be contained in this document, and makes no commitment to update or to keep current the contained information, or to notify a person or organization of any update. Union reserves the right to make changes, at any time, in order to improve reliability, function or design and to attempt to supply the best product possible.