

Multi-line ESD/EMI Protection for Color LCD Interfaces

UM4601 DFN8 2.0×2.0
UM4611 DFN8 1.7×1.3
UM8601 DFN16 4.0×1.6
UM8611 DFN16 3.3×1.3

General Description

The UM4601/UM4611/UM8601/UM8611 is a (L-C) low pass filter array with integrated TVS diodes. It is designed to suppress unwanted EMI signals and provide electrostatic discharge (ESD) protection in portable electronic equipment. This device utilizes solid-state silicon-avalanche technology for superior clamping performance and DC electrical characteristics. They have been optimized for protection of color LCD and camera lines in cellular phones and other portable electronics.

The device consists of identical circuits comprised of TVS diodes for ESD protection, and an inductor - capacitor network for EMI filtering. A typical inductor value of 17nH and a capacitor value of 15pF are used to achieve 24dB minimum attenuation from 800MHz to 2.7GHz. The TVS diodes provide effective suppression of ESD voltages in excess of ±15kV (air discharge) and ±8kV (contact discharge) per IEC 61000-4-2, level 4.

The UM4601 is in a RoHS compliant DFN8 2.0×2.0 package, the UM4611 is in a RoHS compliant DFN8 1.7×1.3 package, the UM8601 is in a RoHS compliant DFN16 4.0×1.6 package and the UM8611 is in a RoHS compliant DFN16 3.3×1.3 package. The leads are finished with lead-free. The small package makes it ideal for use in portable electronics such as cell phones, digital still cameras, and PDAs.

Applications

- Color LCD Protection
- Cell Phone CCD Camera Lines
- Clamshell Cell Phones

Features

- Bidirectional EMI Filter with Integrated TVS for ESD Protection
- ESD Protection to IEC 61000-4-2 (ESD) Level 4, ±15kV (Air), ±8kV (Contact)
- Filter Performance: 24dB Minimum Attenuation from 800MHz to 2.7GHz
- TVS Working Voltage: 5V
- Inductor: 17nH (Typical)
- Capacitors: 15pF (Typical at $V_R=2.5V$)
- Protection and Filtering for Multi Lines
UM4601/4611: Four Lines
UM8601/8611: Eight Lines
- Solid-State Technology

Ordering Information

Part Number	Working Voltage	Packaging Type	Channel	Marking Code	Shipping Qty
UM4601	5.0V	DFN8 2.0×2.0	4	ABA	3000pcs/7Inch Tape & Reel
UM4611	5.0V	DFN8 1.7×1.3	4	AN	
UM8601	5.0V	DFN16 4.0×1.6	8	8601	
UM8611	5.0V	DFN16 3.3×1.3	8	8611	

Pin Configurations

Top View

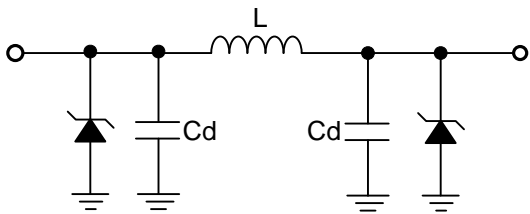
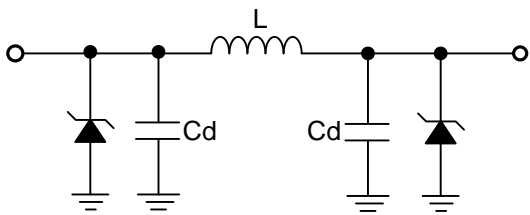
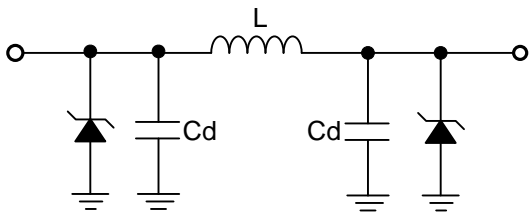
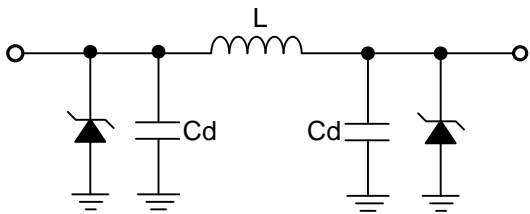
 <p style="text-align: center;">Device Schematic (4X)</p>	<div style="border: 1px solid black; padding: 10px; text-align: center;"> <p>ABA Σ</p> </div> <p style="text-align: center;">●</p> <p style="text-align: center;">M: Month Code UM4601 DFN8 2.0×2.0</p>
 <p style="text-align: center;">Device Schematic (4X)</p>	<div style="border: 1px solid black; padding: 10px; text-align: center;"> <p>AN Σ</p> </div> <p style="text-align: center;">●</p> <p style="text-align: center;">M: Month Code UM4611 DFN8 1.7×1.3</p>
 <p style="text-align: center;">Device Schematic (8X)</p>	<div style="border: 1px solid black; padding: 10px; text-align: center;"> <p>8601:XX</p> </div> <p style="text-align: center;">●</p> <p style="text-align: center;">XX: Week Code UM8601 DFN16 4.0×1.6</p>
 <p style="text-align: center;">Device Schematic (8X)</p>	<div style="border: 1px solid black; padding: 10px; text-align: center;"> <p>8611:XX</p> </div> <p style="text-align: center;">●</p> <p style="text-align: center;">XX: Week Code UM8611 DFN16 3.3×1.3</p>

Absolute Maximum Ratings

Parameter	Symbol	Value	Unit
ESD per IEC 61000-4-2 (Air)	V _{ESD}	±20	kV
ESD per IEC 61000-4-2 (Contact)		±15	
Junction Temperature	T _J	125	°C
Operating Temperature Range	T _{OP}	-40 to 85	°C
Storage Temperature Range	T _{STG}	-55 to 150	°C

Electrical Characteristics

(T_J=25 °C, unless otherwise noted)

Parameter	Symbol	Conditions	Min	Typ	Max	Unit
TVS Reverse Stand-Off Voltage	V _{RWM}				5	V
TVS Reverse Breakdown Voltage	V _{BR}	I _T =1mA	6	8	10	V
TVS Reverse Leakage Current	I _R	V _{RWM} =3.3V			0.1	µA
DC Resistance	R _{CC}			10		Ω
Roll-Off Frequency at -6dB Attenuation	f _R	Z _{source} =Z _{load} =50Ω		350		MHZ
Filter Cut-Off Frequency	f _c	Z _{source} =Z _{load} =50Ω		150		MHZ
Inductance	L			17		nH
Capacitance	C _d	V _R =2.5V, f=1MHZ		15		pF
Total Capacitance	C _{total}	Input to GND, Each Line V _R =2.5V, f=1MHZ	24	30	36	pF

Typical Operating Characteristics

Typical Insertion Loss

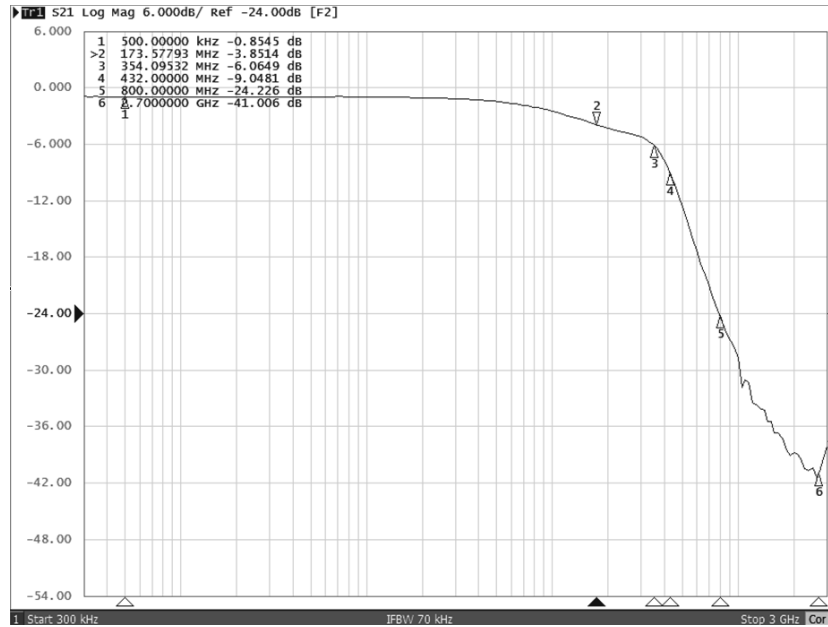

Analog Crosstalk

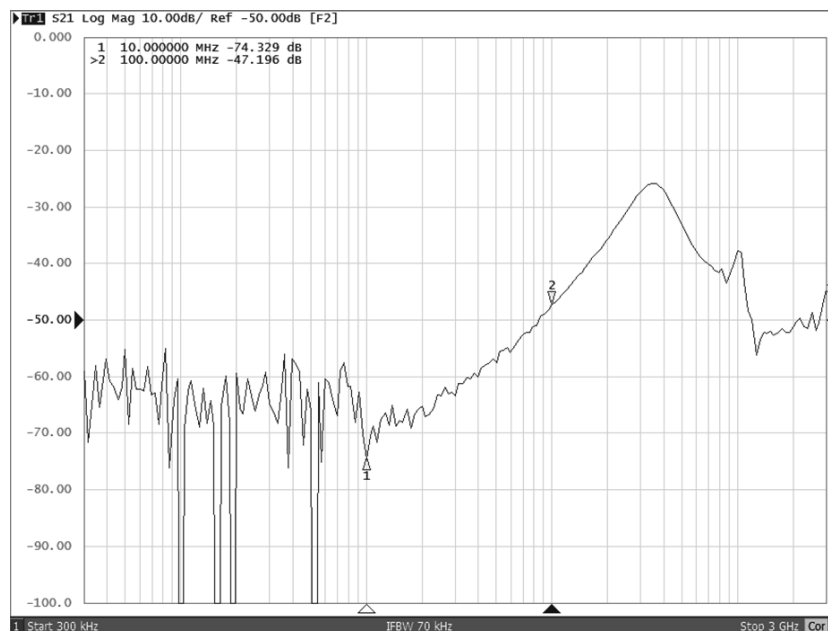

Applications Information

Insertion Loss

Insertion Loss (IL) is used to describe the transmission coefficient between two points in a circuit often described in terms of dB. When examining S parameters, S₂₁ is often described as insertion loss. Insertion Loss and S₂₁ will be used interchangeably from here on out. The insertion loss of a circuit with V_{OUT} and V_{IN} would be expressed as

$$IL=S_{21}(dB)=20\log(V_{OUT}/V_{IN})$$

The setup for measuring insertion loss in a 50Ω system is shown in the figure below. It will be analyzed in a 50Ω environment, so the source impedance and load impedance is 50Ω. The transfer functions then can be analyzed in terms of insertion loss (S₂₁).

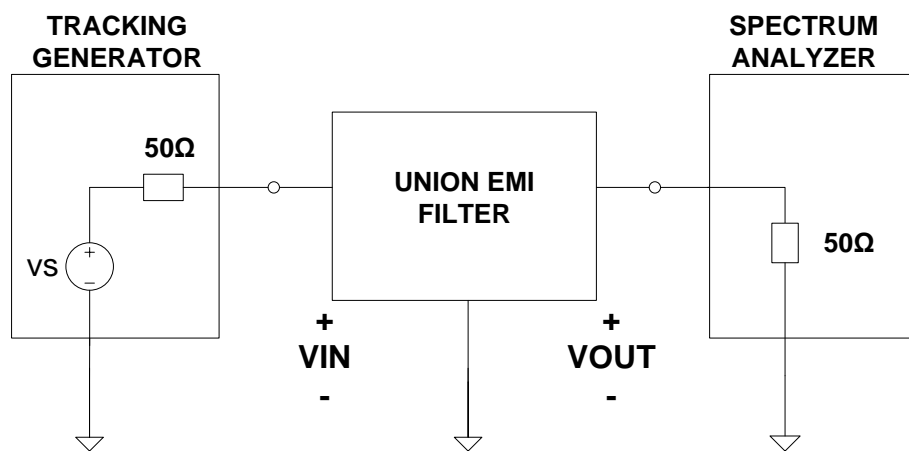

**Test Conditions: Source Impedance=50Ω
Load Impedance=50Ω
Input Power=0dBm**

Cut Off Frequency

Cut off Frequency is the frequency at which the signal strength is 3.0dB less than it is Pass Band. 3.0dB of attenuation equates to half the original signal power. The Pass Band is the range of frequencies that are allowed to “pass” through a filter with minimal attenuation. For our purposes it starts from DC and ends at the cut off frequency.

Device Connection

The UM4601/UM4611/UM8601/UM8611 is comprised of identical circuits consisting of a low pass filter for EMI suppression and dual TVS diodes for ESD protection. The device is in an 8-pin DFN and 16-pin DFN package. Electrical connection is made to all the pins located at the bottom of the device. A center tab serves as the ground connection. The device has a flow through design for easy layout. All path lengths should be kept as short as possible to minimize the effects of parasitic inductance in the board traces.

Ground Connection Recommendation

Parasitic inductance (L) present in the board layout will affect the filtering performance of the device. As frequency (f) increases, the effect of the inductance becomes more dominant. This effect is given by Equation 1.

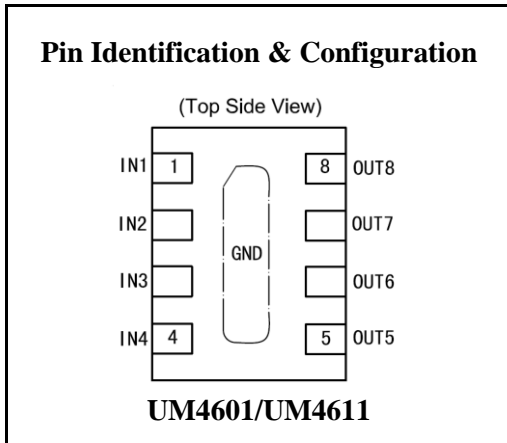

Pin	Identification
1-4	Input Lines
5-8	Output Lines
Center Tab	Ground

Equation 1: The Impedance of an Inductor at Frequency XLF

$$X_{LF}(L, f) = 2 \times \pi \times f \times L$$

Where:
 L = Inductance (H)
 f = Frequency (Hz)

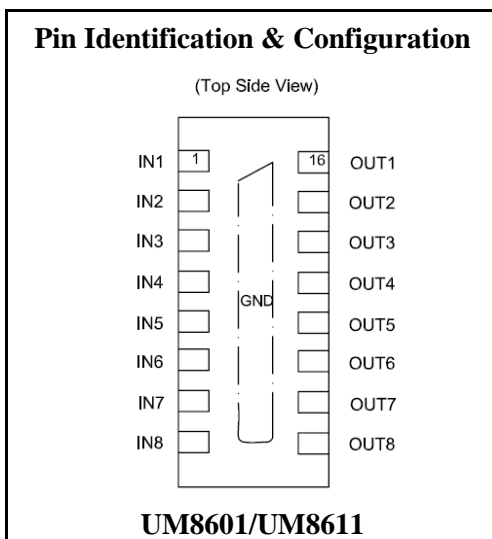

Pin	Identification
1-8	Input Lines
9-16	Output Lines
Center Tab	Ground

Equation 1: The Impedance of an Inductor at Frequency XLF

$$X_{LF}(L, f) = 2 \times \pi \times f \times L$$

Where:
 L = Parasitic Inductance in the PCB (H)
 f = Frequency (Hz)

Package Information

DFN8 2.0×2.0

Outline Drawing

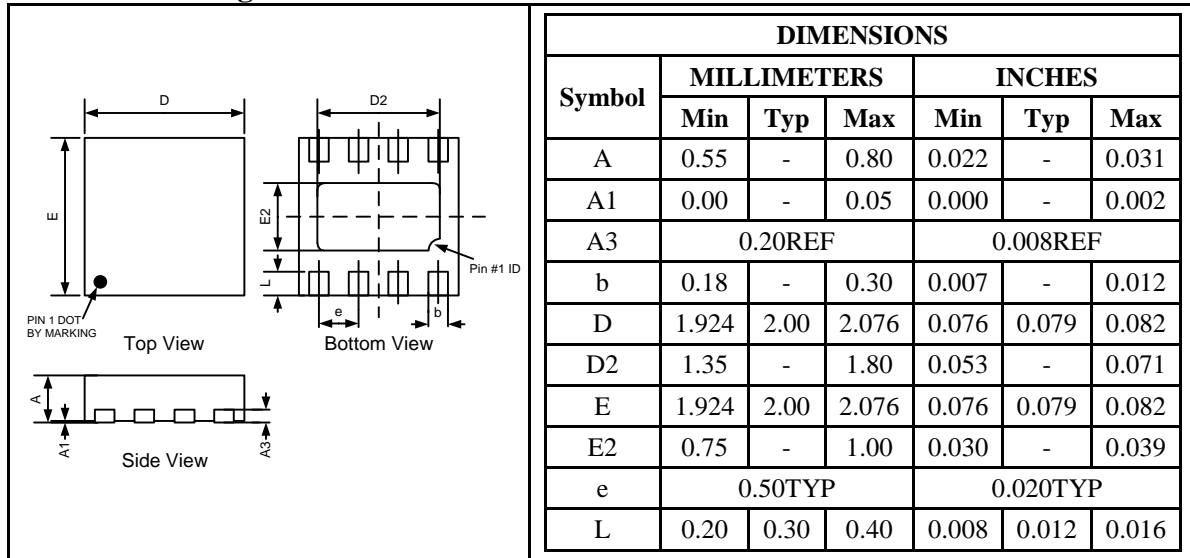

Land Pattern

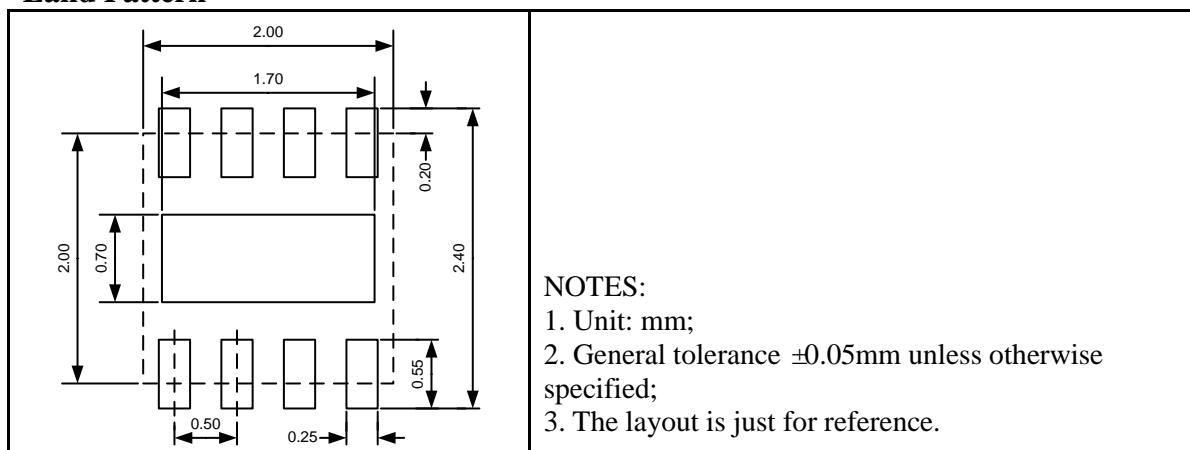

DFN8 1.7×1.3

Outline Drawing

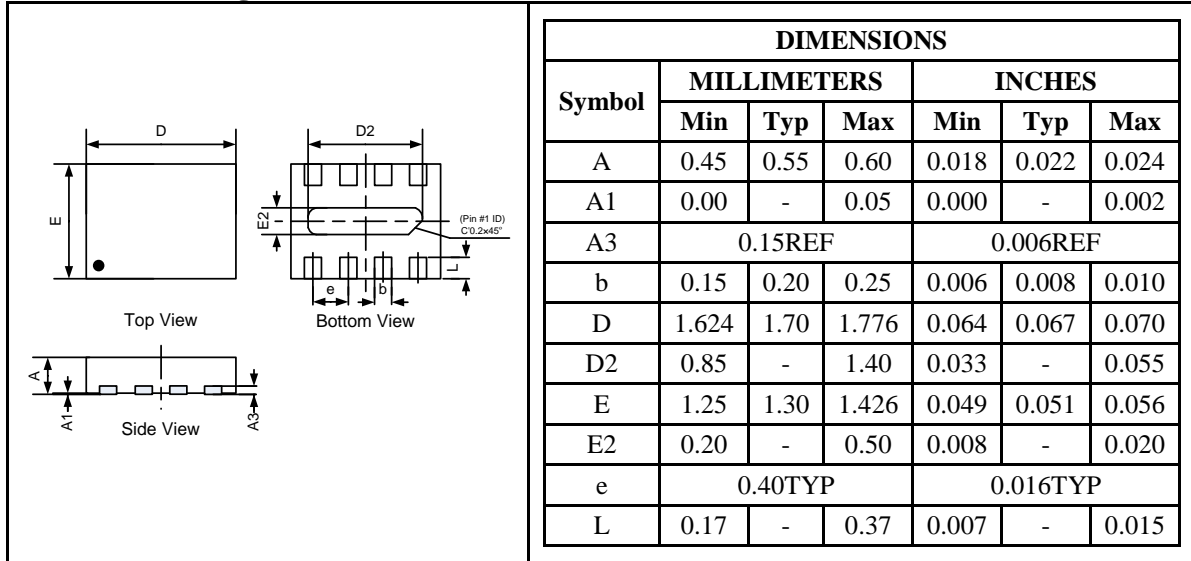

Land Pattern

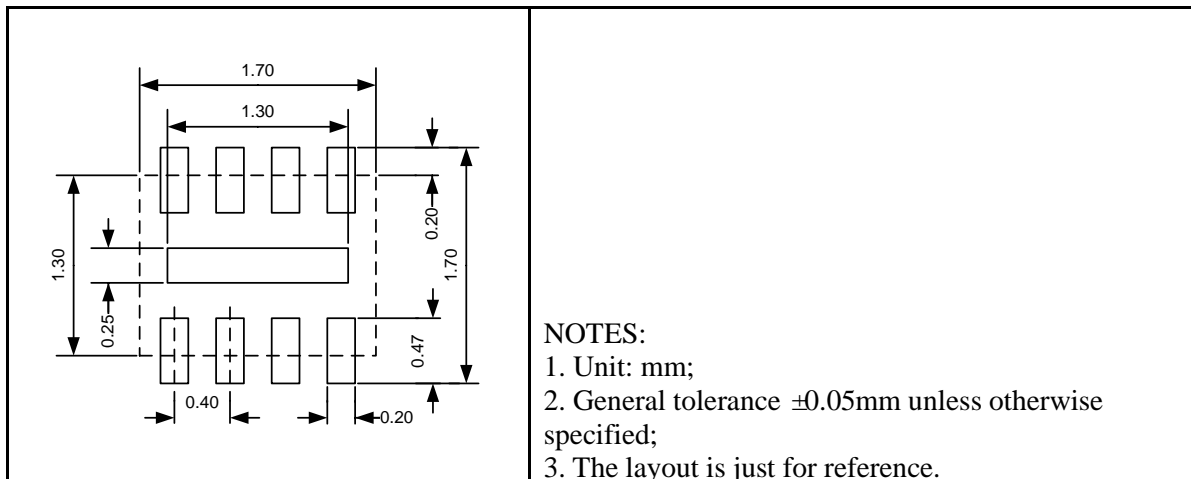

DFN16 4.0×1.6

Outline Drawing

DIMENSIONS						
Symbol	MILLIMETERS			INCHES		
	Min	Typ	Max	Min	Typ	Max
A	0.50	-	0.80	0.020	-	0.031
A1	0.00	-	0.05	0.000	-	0.002
A3	0.203REF			0.008REF		
b	0.15	-	0.30	0.006	-	0.012
D	3.924	4.00	4.076	0.154	0.157	0.160
D2	2.95	-	3.30	0.116	-	0.130
E	1.524	1.60	1.676	0.060	0.063	0.066
E2	0.30	-	0.60	0.012	-	0.024
e	0.50TYP			0.020TYP		
L	0.15	-	0.38	0.006	-	0.015

Land Pattern

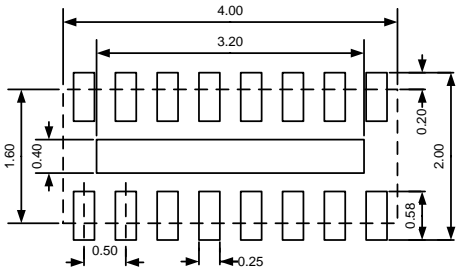
	<p>NOTES:</p> <ol style="list-style-type: none"> 1. Unit: mm; 2. General tolerance ± 0.05mm unless otherwise specified; 3. The layout is just for reference.
---	--

DFN16 3.3×1.3

Outline Drawing

DIMENSIONS						
Symbol	MILLIMETERS			INCHES		
	Min	Typ	Max	Min	Typ	Max
A	0.47	0.55	0.60	0.019	0.022	0.024
A1	0.00	-	0.05	0.000	-	0.002
A3	0.15REF			0.006REF		
b	0.15	0.20	0.25	0.006	0.008	0.010
D	3.224	3.30	3.376	0.127	0.130	0.133
D2	2.45	-	3.00	0.096	-	0.118
E	1.25	1.30	1.426	0.049	0.051	0.056
E2	0.20	-	0.50	0.008	-	0.020
e	0.40TYP			0.016TYP		
L	0.17	-	0.37	0.007	-	0.015

Land Pattern

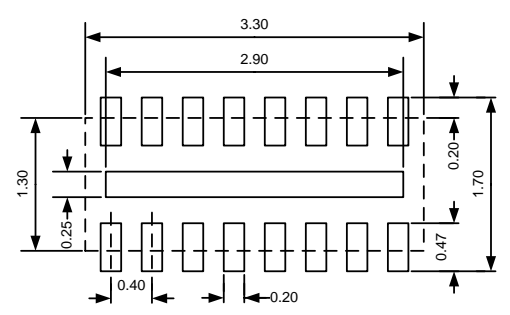
	<p>NOTES:</p> <ol style="list-style-type: none"> 1. Unit: mm; 2. General tolerance $\pm 0.05\text{mm}$ unless otherwise specified; 3. The layout is just for reference.
---	---

Packing Information

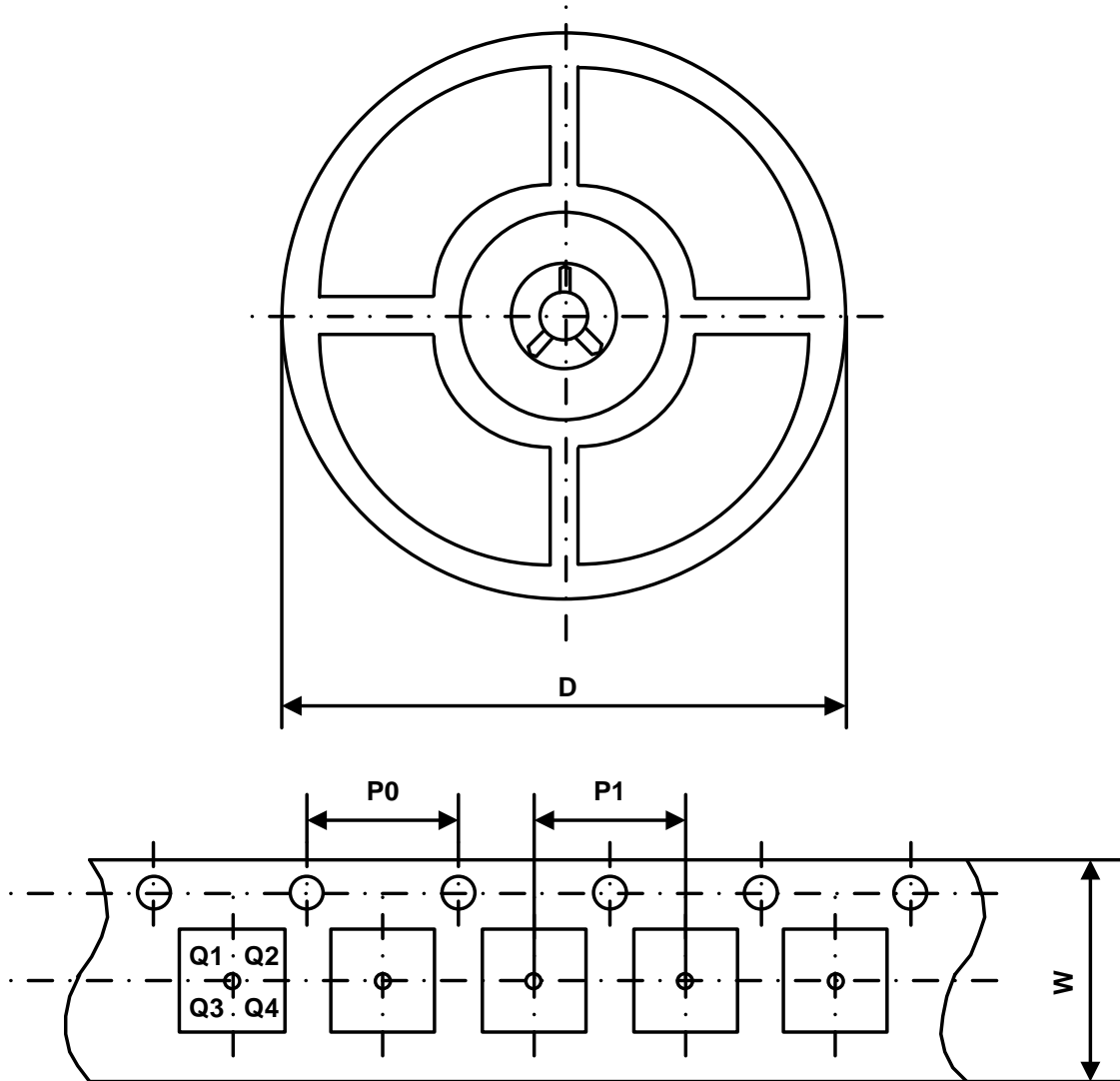

Part Number	Package Type	Carrier Width (W)	Pitch (P0)	Pitch (P1)	Reel Size (D)	PIN 1 Quadrant
UM4601	DFN8 2.0×2.0	8 mm	4 mm	4 mm	180 mm	Q1
UM4611	DFN8 1.7×1.3	8 mm	4 mm	4 mm	180 mm	Q1
UM8601	DFN16 4.0×1.6	12 mm	4 mm	4 mm	180 mm	Q1
UM8611	DFN16 3.3×1.3	8 mm	4 mm	4 mm	180 mm	Q1

GREEN COMPLIANCE

Union Semiconductor is committed to environmental excellence in all aspects of its operations including meeting or exceeding regulatory requirements with respect to the use of hazardous substances. Numerous successful programs have been implemented to reduce the use of hazardous substances and/or emissions.

All Union components are compliant with the RoHS directive, which helps to support customers in their compliance with environmental directives. For more green compliance information, please visit:

<https://www.union-ic.com/Quality.html>

IMPORTANT NOTICE

The information in this document has been carefully reviewed and is believed to be accurate. Nonetheless, this document is subject to change without notice. Union assumes no responsibility for any inaccuracies that may be contained in this document, and makes no commitment to update or to keep current the contained information, or to notify a person or organization of any update. Union reserves the right to make changes, at any time, in order to improve reliability, function or design and to attempt to supply the best product possible.