

---

## Choosing the Right RS-232 Transceiver

### Abstract

This article is intended to help the design engineer sort through the various features available in RS-232 interface products. The main features described are the regulated charge pump, Auto-shutdown, RS-232 compatible versus compliant operation, ESD protection, and data rates including Megabaud operation.

### RS-232 Background

Despite the development of newer digital interface standards, the humble RS-232 serial port is still a very popular means of data transfer. Robust and easy to use, the RS-232 interface is still an attractive alternative to the more demanding and temperamental digital interfaces. This application note describes key features and helps the designer choose the right RS-232 transceiver. Factors to consider include:

- Power supply requirements
- Power consumption/battery-life features (such as auto-shutdown)
- Compliance with signal level standards
- Enhanced ESD protection
- Speed (data rates)

### The Single-Supply RS-232 Transceiver

The RS-232 standard requires signal levels of +5V (minimum) for a low and -5V (minimum) for a high. A higher voltage swing ensures greater noise immunity after the signals travel through lossy cables to RS-232 receivers. Early RS-232 transceivers required dual power supplies. Most circuit boards included a negative power supply solely to power these devices.

Then in 1987, the first single-supply RS-232 device was introduced which includes two charge pumps. The first charge pump doubles +5V to approximately +10V and the second charge pump inverts the +10V charge-pump output to -10V. Since these charge pumps are unregulated, the positive and negative output voltages of the transmitters often drop well below +10V and -10V. The depth of the power supplies drop is a function of both the capacitance of the cable driven by the transmitters and the data rate.

The first single-supply RS-232 transceiver quickly became an industry standard. Many board designers still use it today, despite the fact that single-supply devices have undergone extensive improvements over the years. Understanding the features of new devices will help the design engineer choose the best parts for the application.

### RS-232 Transceivers Powered by Low-Voltage Single Supplies

As power-supply voltages dropped from +5V to +3.3V and lower, single-supply RS-232 transceivers kept pace. The transceivers that are powered from voltages ranging from 3.0V to 5.5V use two regulated charge pumps instead of the unregulated types used in the parts powered by only +5V. Rather than double the input voltage, a single regulated charge pump boosts the input voltage to approximately +5.4V. A second regulated charge pump inverts the +5.4V supply to approximately -5.4V. This constitutes significant power-savings, since it takes less energy to drive the capacitive load of a cable with  $\pm 5.4V$  versus  $\pm 10V$ . Further energy savings is achieved by turning off (skipping cycles) the respective charge pumps once the target output voltage has been achieved.

Questions about noise immunity often arise when design engineers first discover these devices. However the noise immunity of these devices is excellent, despite the fact that the regulated charge pumps work harder to maintain a  $\pm 5.4V$  output as cables become longer and the capacitive load increases. In fact, the  $\pm 5.4V$  output is better maintained with longer cables at higher data rates with devices that incorporate regulated charge pumps over devices that utilize unregulated charge pumps whose outputs are initially of a higher voltage.

## Increased Battery Life through Auto-shutdown Techniques

Many RS-232 transceivers provide a simple shutdown feature that is activated by applying a logic level to the shutdown pin. Since most RS-232 devices are only used for a short period of time, the shutdown feature can save energy and increase the run-time of portable equipment batteries.

Other RS-232 devices incorporate a more advanced feature called Auto-shutdown, which typically limits the shutdown supply current to 1uA. These devices can determine whether a transmission cable is attached to the RS-232 transceiver. If a cable is not attached to the RS-232 transceiver, the unit will go into shutdown until the presence of a transmission cable is detected. A transceiver equipped with the Auto-shutdown feature monitors the RS-232 signals at its receiver inputs to determine whether a cable is connected. When a cable is not present, the signals at the RS-232 receiver inputs are approximately 0V. If the transceiver detects that all the receiver inputs are between -0.3V and +0.3V for greater than 30μS, it assumes that a valid transmitter cable is not connected and will automatically put itself into a low-power mode (shutdown). The part will automatically take itself out of shutdown if any one of the receiver's inputs exceeds +2.7V (i.e., whenever the cable is reconnected). This feature can be overridden with signals that force the device on or off. See Figure 1.

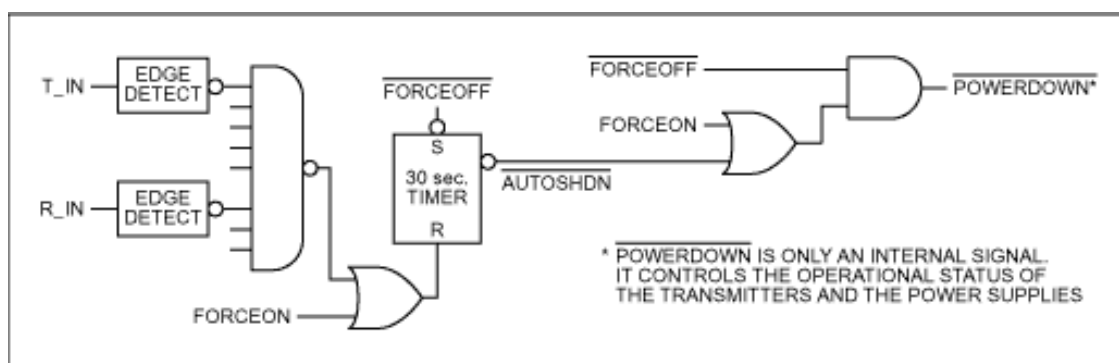

Figure 1. The Auto-shutdown Plus logic incorporated in an RS-232 transceiver, allows the transceiver to stay powered on as long as it detects signal transactions at its transmitter or receiver inputs within 30 μS intervals. Otherwise the transceiver is automatically powered down when the interval between signals is greater than 30 μS. Logic levels applied to the FORCEON and active-low FORCEOFF inputs turn the device's power on and off overriding the Auto-shutdown Plus logic controlled by receiver and transmitter input signal activity.

Auto-shutdown Plus is similar to Auto-shutdown in that it is designed to save power by shutting down the RS-232 device whenever it is not in use. The Auto-shutdown Plus shuts down the transceiver when the cables are disconnected, and when the cable is connected and data edges haven't been detected for 30 μS or more.

This way you can get the benefit of an automated shutdown regardless of whether the cable is connected. Auto-shutdown-Plus devices monitor both the RS-232 receiver inputs and the digital transmitter inputs for signal activity; shutdown ensues if no activity is present on any of these lines for 30 μS. As with Auto-shutdown, you can force on or off the device using pins that override the Auto-shutdown Plus feature. See Figure 1.

## Compatible Versus Compliant

To be compliant with the RS-232 specification, transmitters are required to provide a ±5V output signal level. For RS-232 receivers to be compliant, their thresholds must be ±3V maximum. Therefore, these devices operate with a healthy ±2V noise margin. Thus it is possible to erode a percentage of the margin and still maintain accurate data transmissions. Margins are reduced when transmitter output voltages span a narrower range. When transmitter outputs are a minimum of ±3.7V, they are considered to be compatible, instead of compliant RS-232 outputs. For

example, if you power an RS-232 device that doesn't contain charge pumps (thus less expensive and smaller) with  $\pm 5V$  supplies, its output voltages cannot possibly reach  $\pm 5V$ . A device operated under these conditions with transmitter outputs of  $\pm 3.7V$  at minimum is said to be RS-232 compatible instead of compliant.

### Enhanced ESD Protection

All RS-232 devices include ESD protection structures on their terminals to protect against electrostatic discharges encountered during handling and assembly. Several manufacturers offer devices with both standard and enhanced protection. Since the standard and the enhanced protection parts are almost always available with the same pin configuration, adding devices with enhanced ESD protection typically does not require any modifications to an existing PC board.

Some applications require  $\pm 15kV$  ESD protection on both the RS-232 and the CMOS digital terminals. For example, in order to reduce cost and size, cell phones do not include the RS-232 transceiver in the phone itself. Instead CMOS level signals are routed through the connector at the bottom of the phone. If the cell-phone owner wants to connect to the RS-232 port of a laptop, he or she will purchase a "data-lump" cable, which includes an RS-232 transceiver. In this situation, both sides of the RS-232 transmitters and receivers are brought out to connectors, exposing them to increased ESD risk. In such cases, it may be desirable to have extended ESD protection on both the RS-232 and CMOS sides of the transmitters and receivers.

### Data Rates

The latest RS-232 specification calls for data rates of 20kbps or below. Despite this restriction, the data rates of most RS-232 transceivers far surpass that speed. In fact, today's RS-232 transceivers reach speeds up to 1Mbps. See Figure 2 for an example of a transceiver operating at 1Mbps. To reach such speeds, these devices violate another RS-232 specification, the maximum allowed transmitter-output slew rate of  $30V/\mu s$ . The RS-232 specification requires that transmitter outputs do not exceed this slew rate, thus reducing the amount of noise generated by fast edges. The outputs of transceivers that operate at speeds of up to 1Mbps are also slew-rate limited, however at a slew rate that exceeds the RS-232 specification. The outputs of these transmitters emit noise at higher frequencies than do their slower-slew-rate counterparts. The faster slew rate of these devices also creates another concern, compatibility with slower devices. If a part capable of Megabit-per-second operation transmits data at high speeds, a transceiver capable of operating at the same speed must be present at the other end of the cable. If a slower speed device is instead used at the other end of the cable, operation at slower data rates will probably work, although not guaranteed.

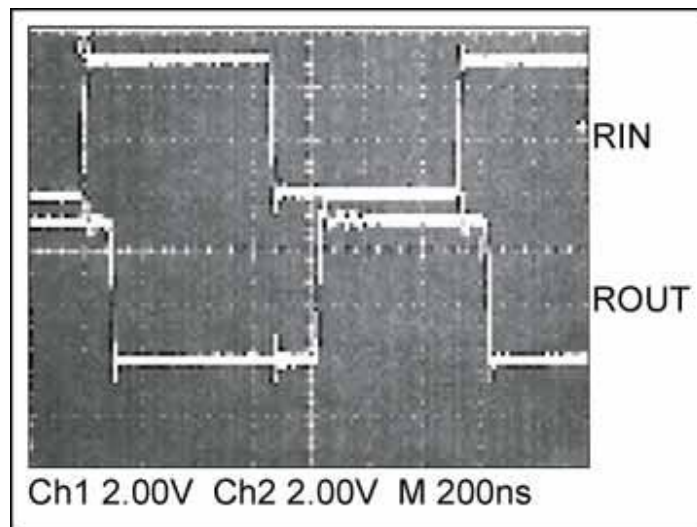

Figure 2. The above oscilloscope photo shows an RS-232 receiver operating at 1Mbps.

---

**IMPORTANT NOTICE**

The information in this document has been carefully reviewed and is believed to be accurate. Nonetheless, this document is subject to change without notice. Union assumes no responsibility for any inaccuracies that may be contained in this document, and makes no commitment to update or to keep current the contained information, or to notify a person or organization of any update. Union reserves the right to make changes, at any time, in order to improve reliability, function or design and to attempt to supply the best product possible.



Union Semiconductor, Inc

Add: 7F, No. 5, Bibo Road, Shanghai 201203

Tel: 021-51097928

Fax: 021-51026018

Website: [www.union-ic.com](http://www.union-ic.com)