

## Low Resistance Analog Switches Permit Speaker Switching in Audio Devices

Union Semiconductor, Inc.

CMOS Analog switches have been available from the semiconductor industry for more than 30 years. The venerable MC4066 is an example of a still popular device in the “4000” family. The MC4066 exhibits roughly 500  $\Omega$  series resistance (RON). Switches of this style are still popular and useful for controlling high impedance signals. In the past few years the industry has begun to offer switches in the 10–20  $\Omega$  RON range, and in 2003 switches with RON values of less than 1.0  $\Omega$  became available. The UM4684 and UM4685 are two examples of switches with RON  $< 1.0 \Omega$ , capable of switching an audio output signal that is directly connected to a speaker in portable application.

In the cell phone marketplace, it is virtually mandatory to include a jack for external microphone/speaker connections. Many places in the world do not permit operation of a cell phone when driving, except in a hands free mode. It is very common to see people walking and talking into a lapel mounted microphone, with the earpiece placed in the users ear. It is potentially dangerous to have the ring tones that are generated at high levels directed into the earpiece. The use of a mechanical switch to disable the speaker and direct the signal to the earpiece is therefore not feasible. This design gets further strained, when one adds all the new features consumers are demanding MP3 stereo audio playback and FM stereo radio are two such desirable features. The commuter riding the metro or suburban train would want to have MP3 to have music playback, of his choice, and FM radio for news. With a rechargeable battery, and a high power microprocessor on board, all that is needed to add MP3/FM functionality is an external memory card and software, and possibly an FM tuner chip. For MP3/FM the user will likely demand stereo playback. Both MP3 and commercial FM radio require a stereo audio amplifier. If the designer had to switch the routing between the stereo earpiece and the internal speaker, there are two choices:

- a. two stereo audio output amplifiers
- b. one stereo amplifier and an electronic switch

At first blush, it might appear that two amplifiers might be the desirable way to go. with the advent of some new switching technology will show this is not the case. If the designer were to use two stereo amplifiers, he needs to steer the signals at low level to the appropriate amplifier. He also needs to Enable/Disable the appropriate amplifier to reduce the standby current. Many chip vendor supplies a small stereo amplifier capable of  $> 100 \text{ mW}$  output, that can be used for this purpose. Many audio power amplifiers are delivered in a Micro-10 surface mount package that is  $3 \times 5 \text{ mm}$ , occupying  $15 \text{ mm}^2$  of board space. A second amplifier would occupy an additional  $15 \text{ mm}^2$  of space. The signals need to be routed to the appropriate amplifier, and a pair of SPDT analog switches could be used. In addition, an inverter is needed to permit the Enable/Disable function to be done with one line from a microcontroller.

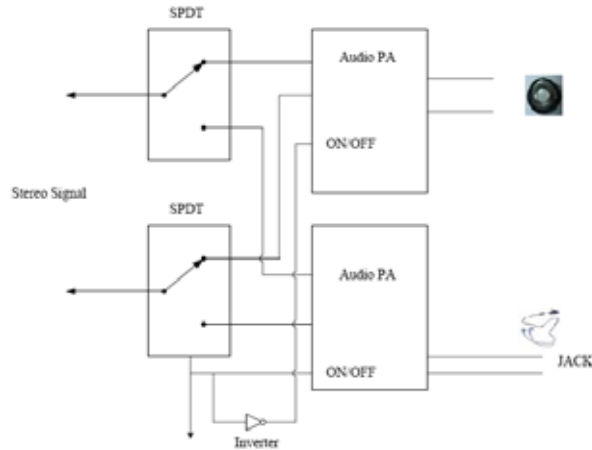

Fig 1. Two Stereo Amplifiers to Switch Earphone/Speaker

Union Semiconductor offers two new low impedance switches that exhibit less than  $1 \Omega$  RON. The UM4684 is a dual analog switch with a typical RON of  $0.5\Omega$ . It is available as a flip chip or MSOP device. In this form it occupies only  $3 \text{ mm}^2$  of board space.

Alternatively a new analog switch that exhibits  $\approx 0.5 \Omega$  series resistance can be used. This will insert less than  $0.5 \text{ dB}$  loss to the system when using  $8\text{--}16 \Omega$  speakers. The circuitry in Figure 2 is amazingly simple. It is almost as if we have a mechanical switch that is electrically controlled. The new embodiment reduces the number of parts to one amplifier such as NCP2809, one UM4684 analog switch. Cost and almost more importantly board space is considerable reduced. The new circuit accomplishes the same function with 3 fewer parts board space, cost and complexity.

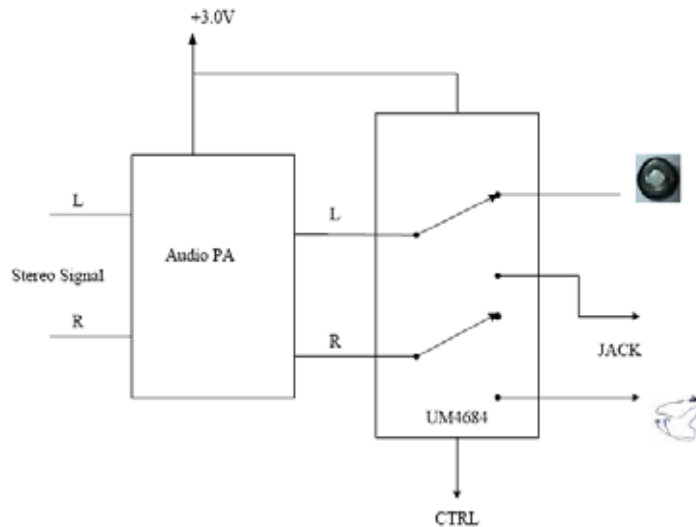

Fig 2. Speaker Earphone Switching