

## Balanced modulator/demodulator employing UM4684

Union Semiconductor, Inc.

The UM4684 can be used as a balanced modulator/demodulator at carrier frequencies up to 500kHz. Higher frequencies are possible, but as frequency increases, small imbalances in the UM4684's internal capacitance and resistance gradually impair performance. The modulator circuit employing UM4684 is shown as Fig.1.

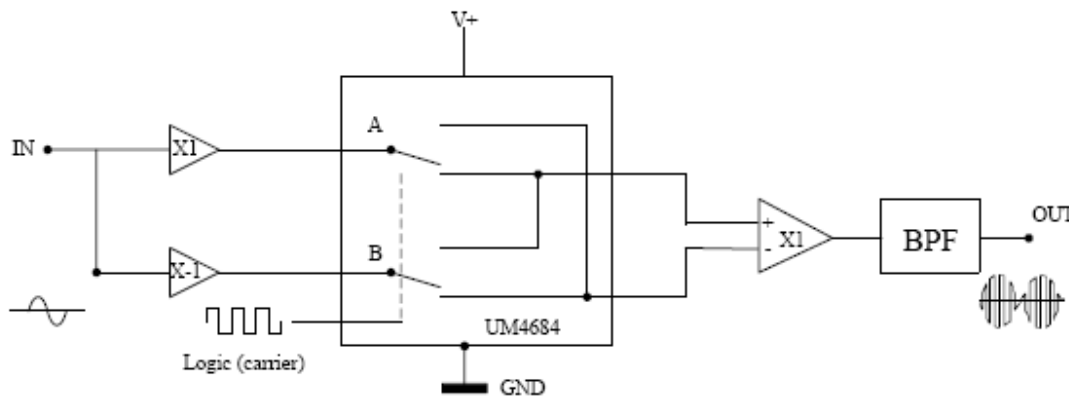

Fig 1. Modulator Using UM4684

Input signal is fed into common node of UM4684, carrier is applied as a logic-level square wave to analog switch control terminal, for best carrier suppression, the square wave should have a precise 50% duty cycle, and both the input and output signals should be symmetrical about ground. Bypass V+ to GND with 0.1 $\mu$ F ceramic capacitors, as close to the IC pins as possible. In critical applications, carrier suppression can be optimized by trim duty cycle. In signal lines, balancing both capacitance and resistance to GND produces the best carrier suppression. Since the UM4684 generates an output signal consisting of the sum and difference frequencies of the two input signals, and band pass filter is required to select the upper frequency we want. It can also be used as a

double balanced mixer.

Similarly, UM4684 also can be used as demodulator/ down conversion mixer as shown in Fig 2.

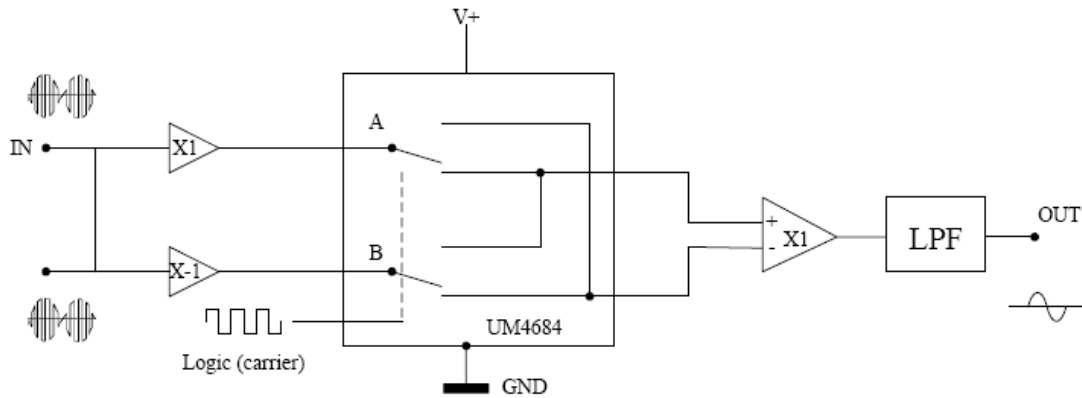

Fig 2: UM4684 as demodulator

High frequency input signal is fed into IN port. Local logic level square wave sync as carrier is applied to analog switch control terminal to demodulate the high frequency input signal, a low pass filter is followed to get the low frequency demodulated signal.